

# How To – Apply Build Surface FELIX Tec 4

7 September 2017

Revision 1

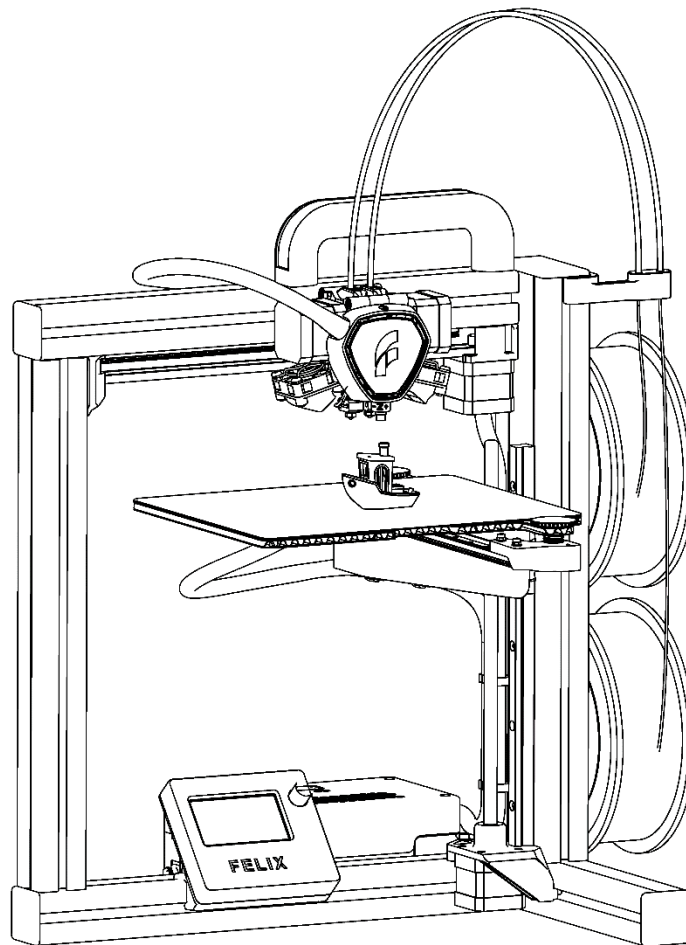

# 1 Introduction

This manual will describe how to change hot-ends on the FELIX Tec 4.

## 1.1 Recommended Parts

1. [Kapton Sticker 270 x 300 mm](#)

## 1.2 Recommended Tools

1. Box cutter
2. Plastic spatula or card
3. Alcohol
4. Cloth

# 2 Apply Build Surface

## 2.1 Preparations

Start with the following steps:

1. Remove the old build surface
2. Degrease the surface of the flexible buildplate using alcohol and a piece of cloth

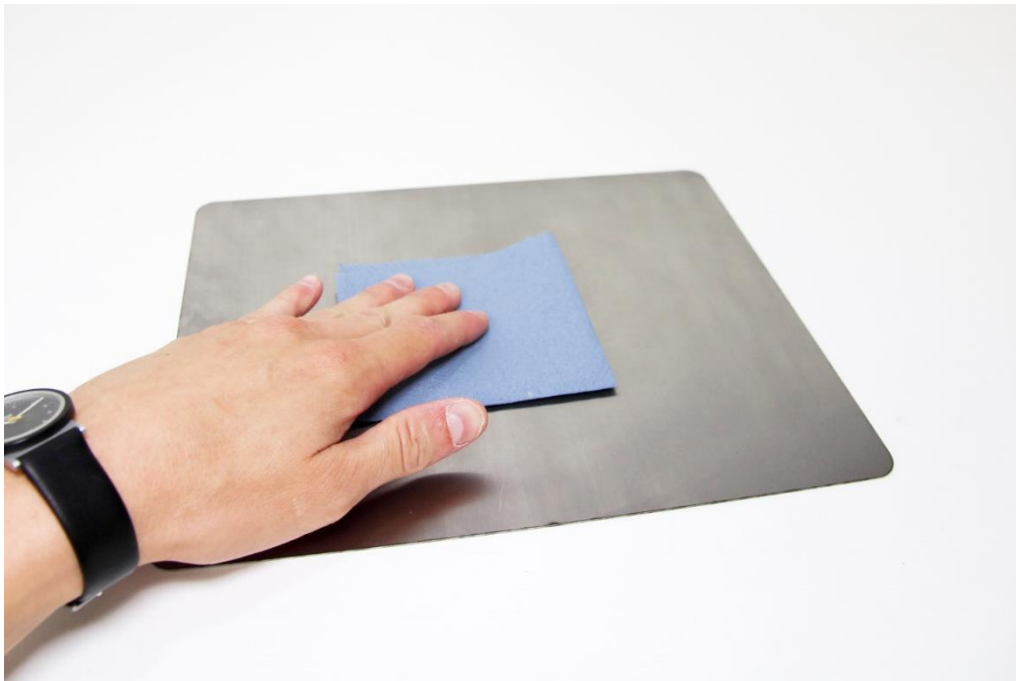

- Place the flexible buildplate on the build platform and select "Control" -> "Preheat" and wait until the status of the build platform displays "B: 55°C.

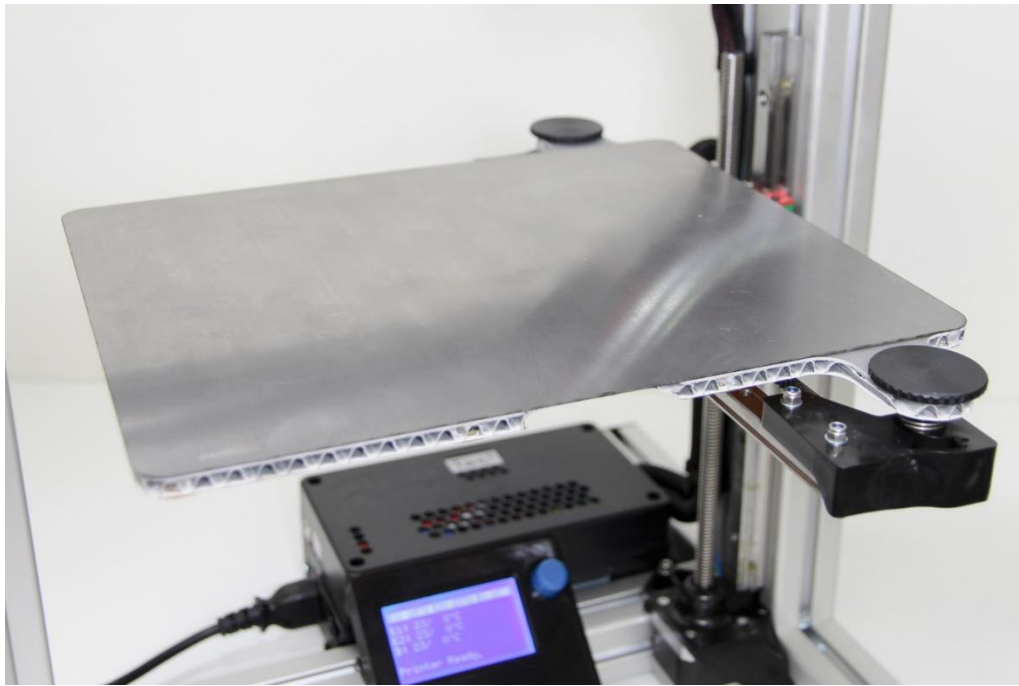

- Peel off the protective sheet at one corner of the Kapton tape. Next stick the exposed adhesive to the flexible buildplate at one corner.
- Continue peeling off the protective sheet and at the same time stick the tape to the flexible buildplate using a plastic spatula or card in a zigzag motion to avoid air bubbles.



6. Remove the excess kapton tape using a box cutter around the edges of the flexible buildplate



If you are unable to continue or have any questions, you can check at the support section of our website or you can contact us directly:

Website: [www.felixprinters.com/support](http://www.felixprinters.com/support)

Email: [support@felixprinters.com](mailto:support@felixprinters.com)

Telephone: +31 (0)30 30 31 387

Address: Zeemanlaan 15, 3401MV IJsselstein, The Netherlands

Kind regards,  
FELIXprinters