

# User Manual

## Tec 4 / 3 series cover unit

22 December  
2020

Revision 01

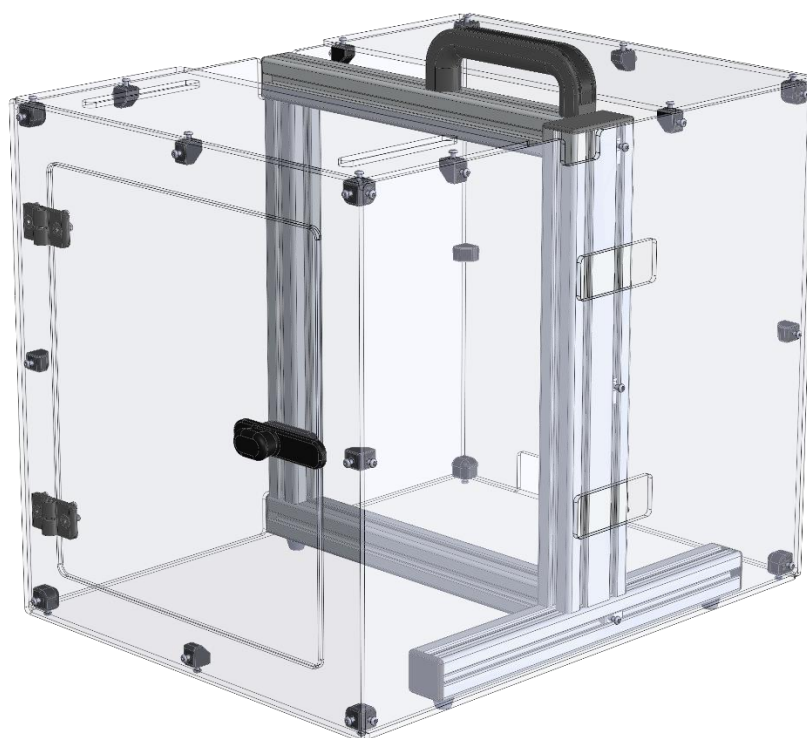

# 1 Introduction

Thank you for choosing FELIXprinters!

It is highly recommended to read this manual. It explains in short how to make your first print and contains essential tips to operate the printer properly.

If you are unable to continue or have any questions, you can check at the support section of our website or you can contact us directly:

Website: [www.felixprinters.com/support](http://www.felixprinters.com/support)

Email: [support@felixprinters.com](mailto:support@felixprinters.com)

Telephone: +31 (0)30 30 31 387

Address: Zeemanlaan 15, 3401MV IJsselstein, The Netherlands

Kind regards,

FELIXprinters

## 2 Contents

1	Introduction.....	1
2	Contents.....	1
3	Assembly steps.....	2
4	Bill of materials.....	7
4.1	FELIX Tec Series - Cover Unit - New style - 105 189.0.....	7

### 3 Assembly steps



We will start from the bottom and work our way up from there. For the first step find the bottom plate. Make sure the long side is on the front.

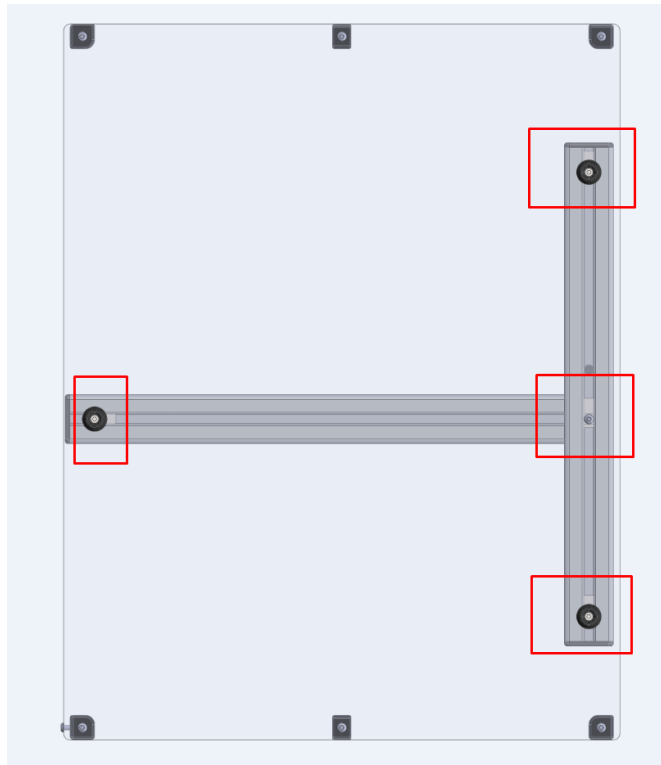

Start by inserting 4 m4 t-slots into the frame at the bottom these will hold the plate with 1 m4 X 12 and 3 m4 X 20 with the feet and 3 m4 washers.

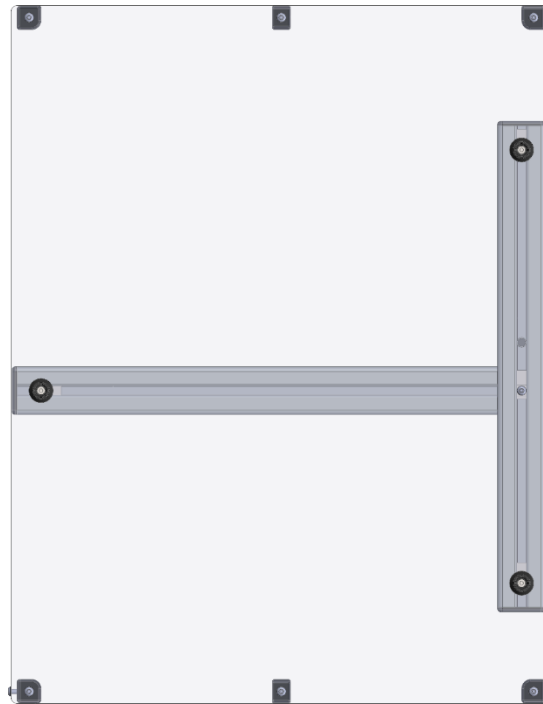

Then we need 4 corner blocks and 2 middle blocks, these are connected with M4 X 12.

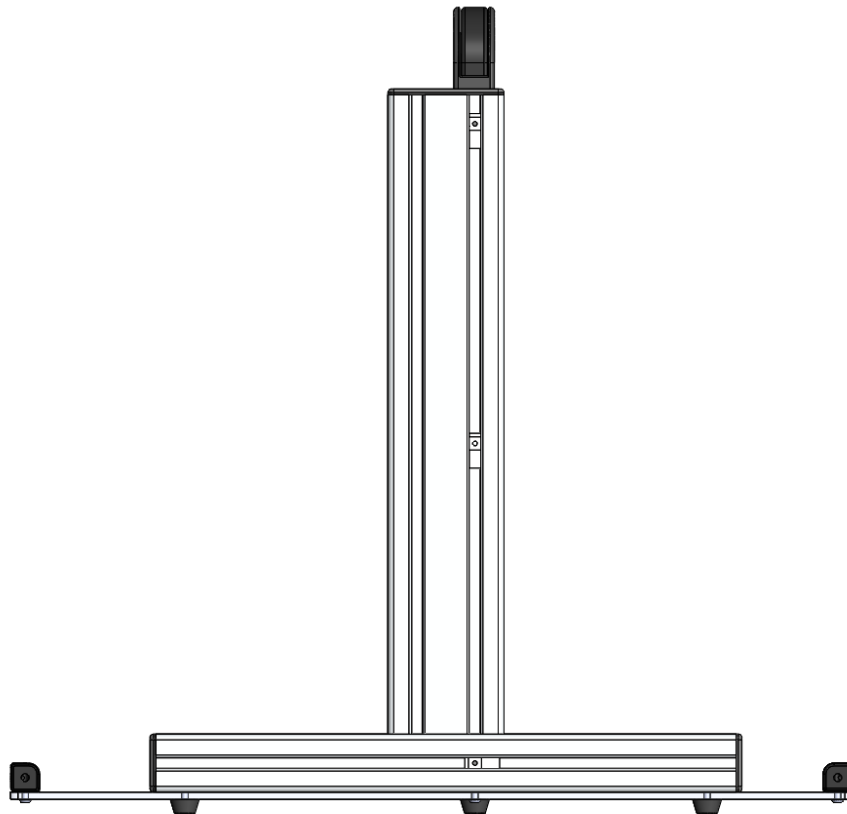

Also insert 3 m4 t-slots on the right side.

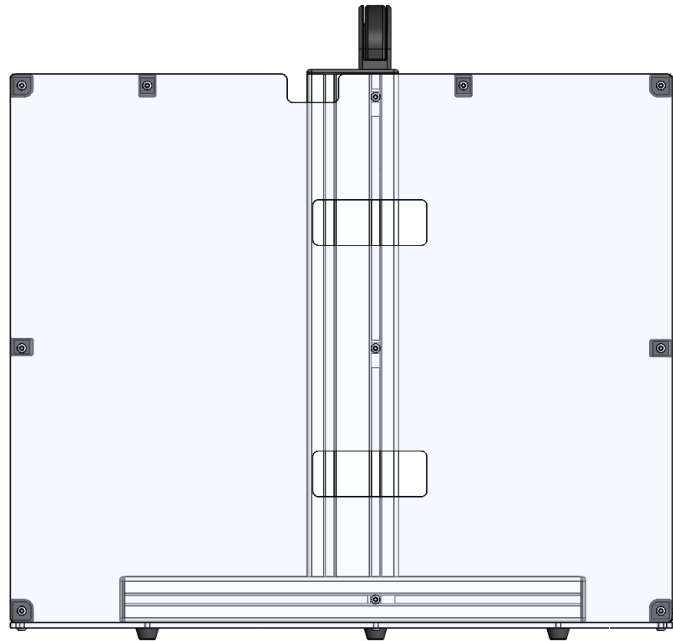

Now place the right plate on the side and screw it down with 3 m4 x 12 to the frame using the t slots from the previous step. After that place the missing corner block and attach those with m4 x 12 as well.

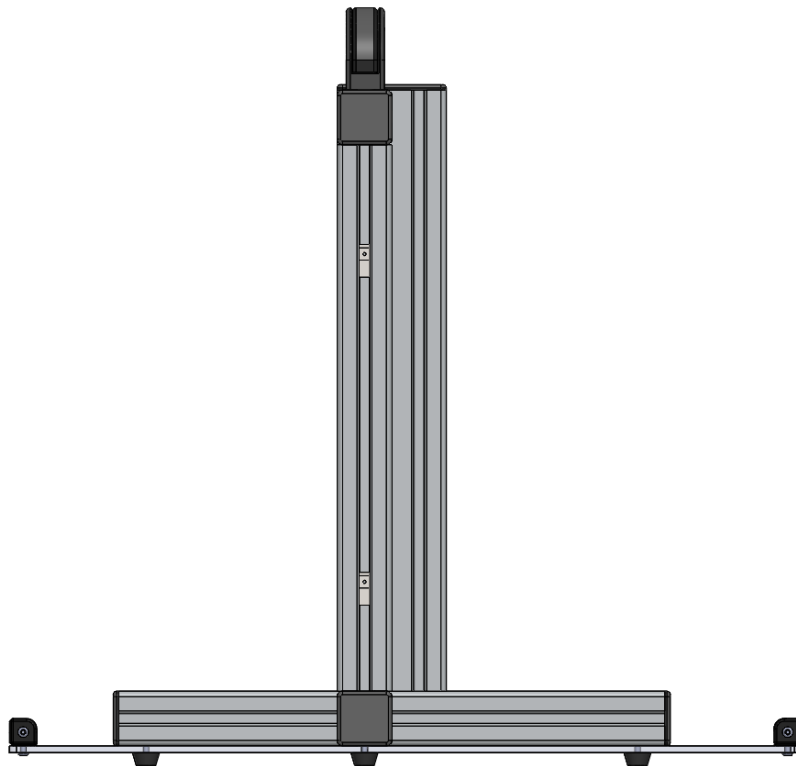

Insert 2 m4 t slot on the left side of the frame.

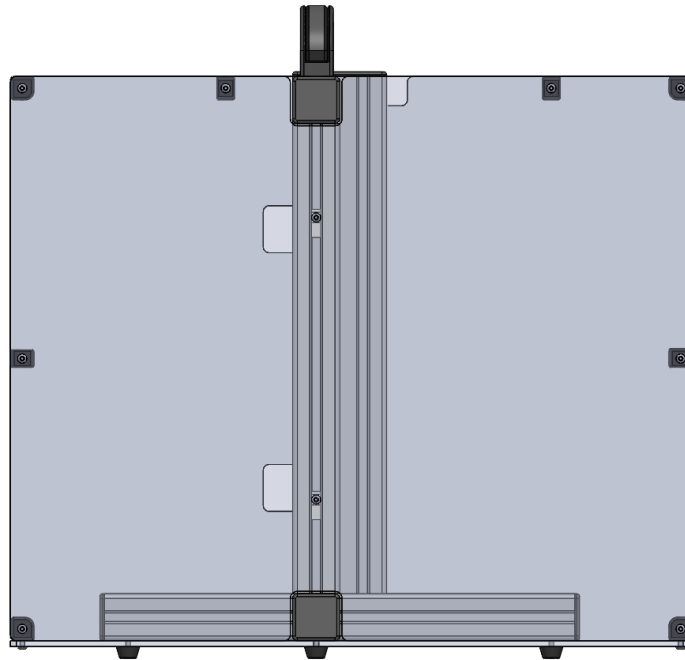

Now place the left plate on the side and screw it down with 2 m4 x 12 to the frame using the t slots from the previous step. After that place the missing corner block and attach those with m4 x 12 as well.

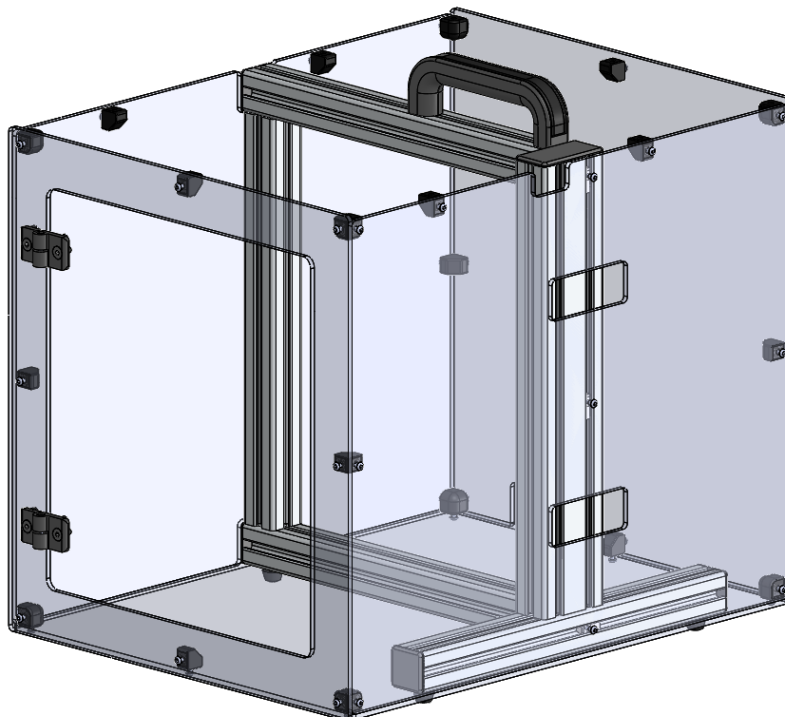

Now attach the front and back and insert the hinges for the front door.

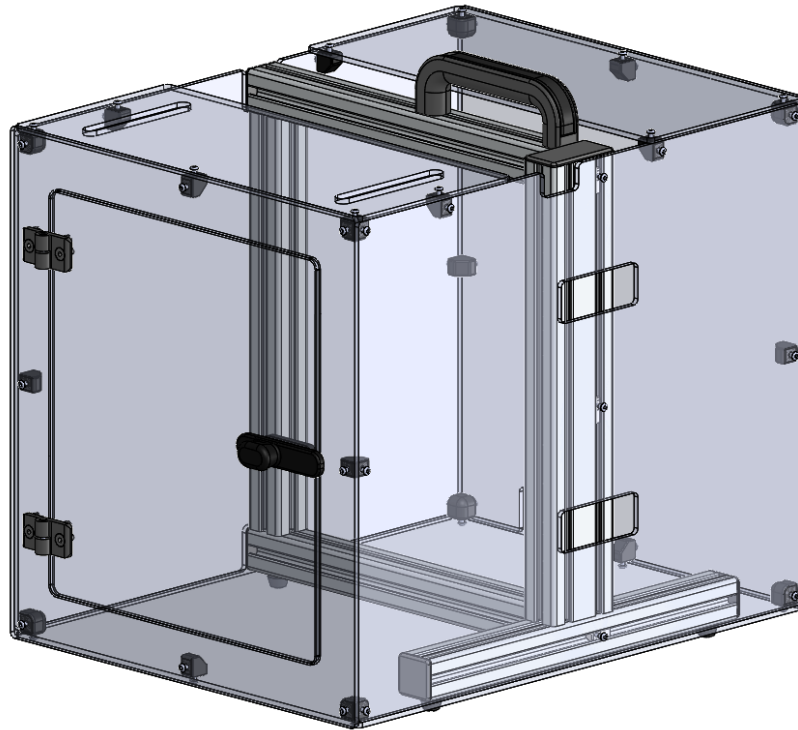

Now insert the 2 top plates and attach them with m4 x 12 after this you're done!

## 4 Bill of materials

### 4.1 FELIX Tec Series - Cover Unit - New style - 105 189.0

#	Part No.	Part	Quantity
#	Part No.	Part	Quantity
1	190 221.0	Cover set FELIX Tec 4.1 / 3.1 New Style	1
2	130 214.0	Corner bracket housing - Pro 3 - 03207_0	8
3	130 225.0	Middle bracket housing - Pro 3 - 03218_0	12
4	140 068.0	M4 x 10 - HEX SOCKET - DIN 912	48
5	140 018.0	M4 x 12 - HEX SOCKET - DIN 912	5
6	140 020.0	M4 x 20 - HEX SOCKET - DIN 912	3
7	170 027.0	Damping foot 2 (Foot Pro)	3
8	110 022.0	T-Slot Nut V 8 St M4	8
9	140 110.0	M4 - insert brass	2
10	140 018.0	M4 x 12 - HEX SOCKET - DIN 912	2
11	190 232.0	FELIX Tec / 3 Door Handle New Style	1
12	140 151.0	M6 x 20 - HEX CSK - DIN 7991	4
13	140 148.0	M6 - LOCK NUT - DIN 985	4
14	190 234.0	Hinge - plastic - opens left - Pro L/XL - Mark 2	2
15	140 025.0	M4 - Washer - DIN125A	3
16	140 149.0	M6 - Washer - DIN 125A	4