

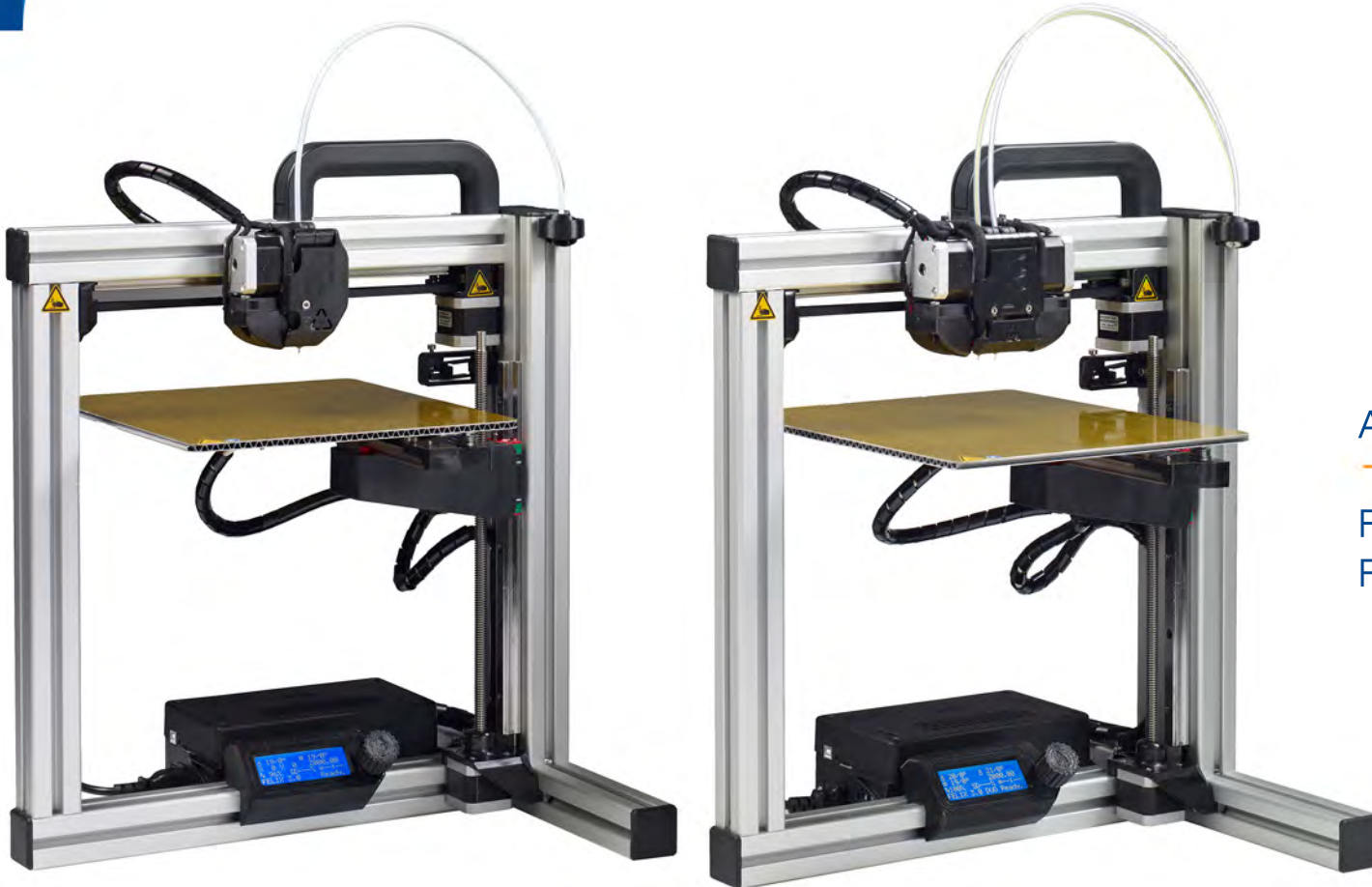

FELIX 3.1 assembly manual



Assembly manual for:

FELIX 3.1 Single
FELIX 3.1 Dual

copyright information

This document contains proprietary information that is protected by copyright. no part of this document may be photocopied, reproduced, or translated to another language without the prior written consent of FELIXrobotics BV.

Felixrobotics BV

Zeemanlan 15, 3401 MV, IJsselstein, the Netherlands, Copyright © 2015 FELIXrobotics BV

INTRODUCTION

Dear Customer,

First of all, thank you choosing FELIXprinters! To get your Felix printer up and running as fast and painlessly as possible please follow this manual carefully. Please don't take any shortcuts unless you know what you're doing. It's better to spend a few minutes extra on reading, than to wait a week for new parts.

When things are unclear or if you have any remarks or tips, please contact us at support@FELIXprinters.com. We also recommend looking on our forum and getting yourself a forum account. You will benefit from the ability to get downloadable and printable upgrades for your printer. Also it is a great source to obtain and share knowledge about your 3d printer and 3d printing in general.

Before starting to build the kit, it is recommended that you check if all parts are present by comparing to the bill of materials in the appendix of this document.

Have fun building!

Kind regards,

FELIXprinters.

INDEX:

Description:	Steps:	Page:
Required tools	5	
Frame	1 - 8	6
Z-axis	9 - 28	8
X-axis	29 - 41	11
Extruder	42 - 59	15
Y-axis and printbed	60 - 80	23
Handle	81 - 83	27
Electronics Box	84 - 92	28
Wiring	93 - 102	30
Display	103 - 113	34
BOM (Bill of Materials)		37

Required tools:

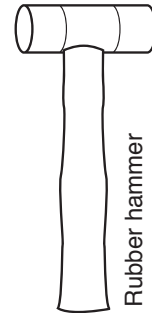
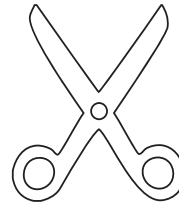
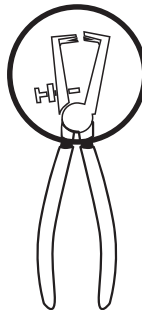
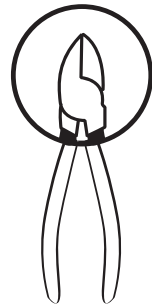
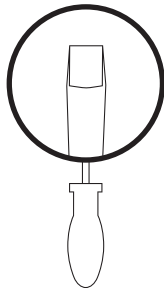
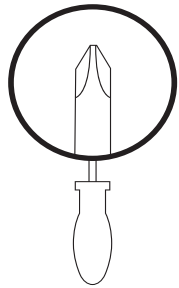
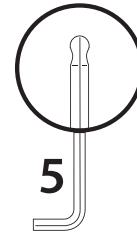
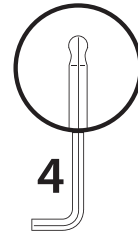
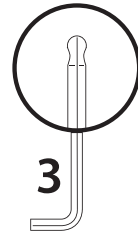
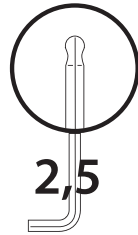
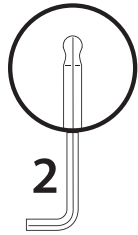
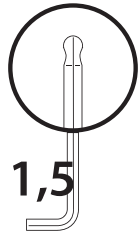

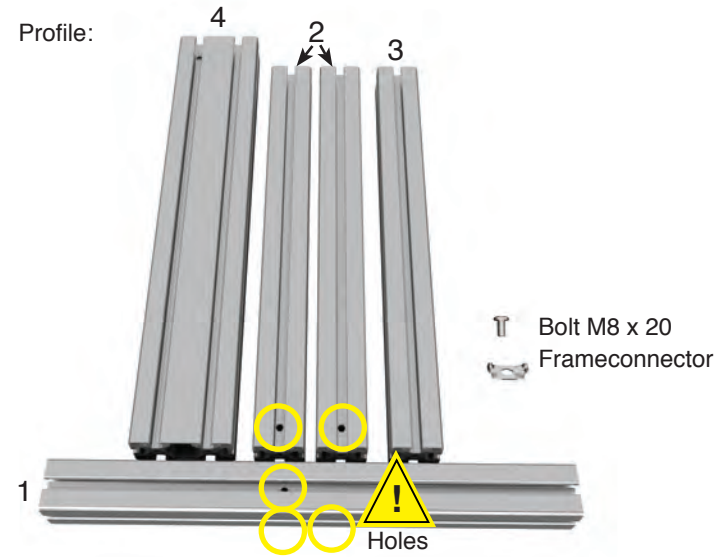
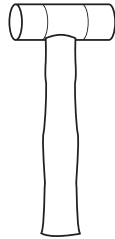
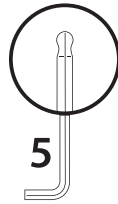

Rubber hammer

Tools:



1

-  2x Bolt M8 x 20
-  2x Frameconnector profile 4

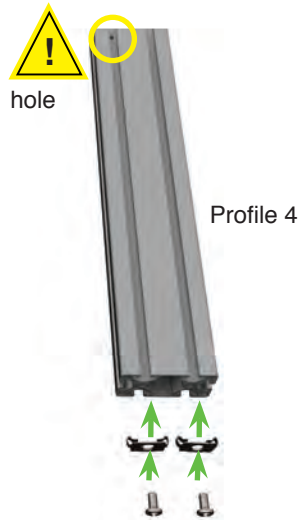

2

profile 1

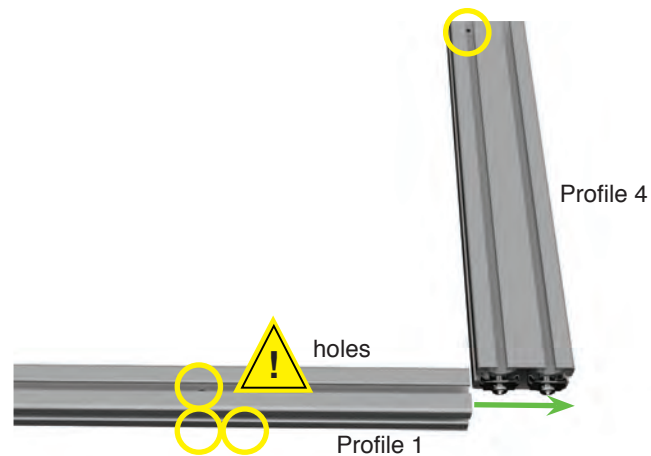

3

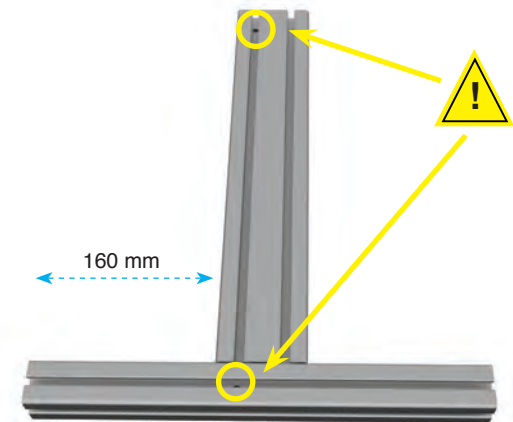

4

- 2x Bolt M8 x 20
- 2x Frameconnector
- 2x profile 2

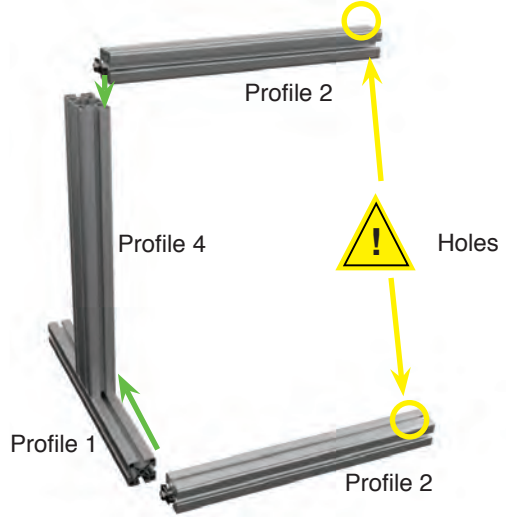

5

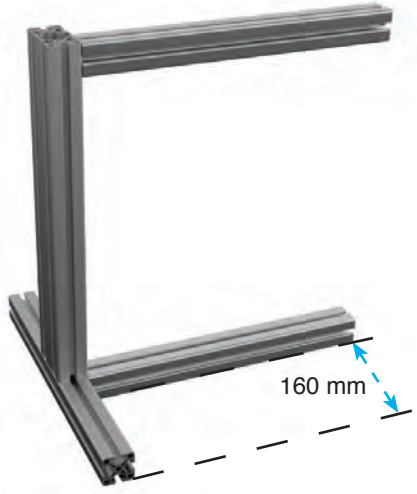
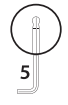

6

- 2x Bolt M8 x 20
- 2x Frameconnector
- 1x profile 3

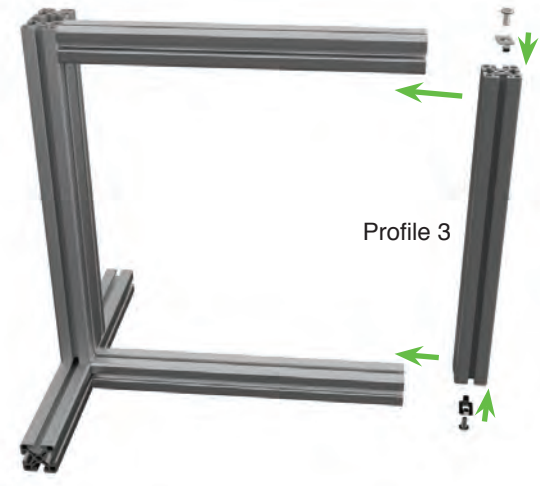

7

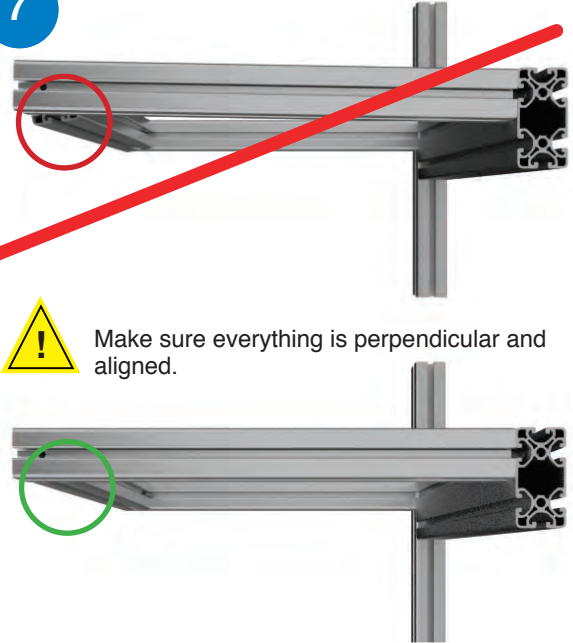

! Make sure everything is perpendicular and aligned.

8

- 4x End cap square
- 1x End cap rectangle

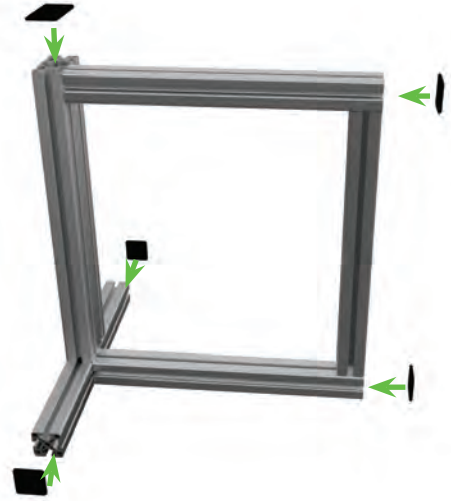

The frame is now finished.

Tools:

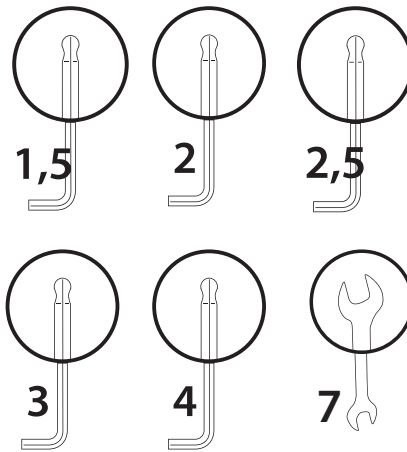

Example mounting T-slots:

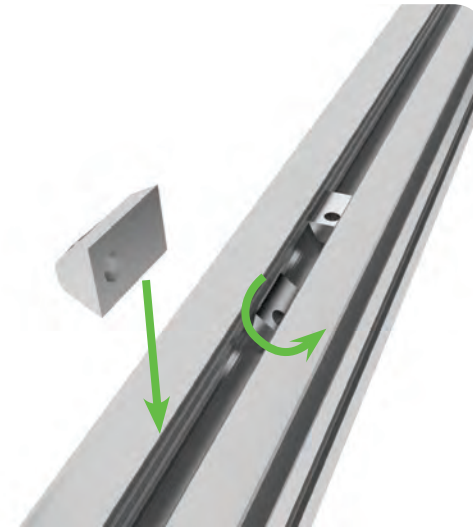

- 9 4x CSK bolt M3x8
- 1x Motor
- 1x Z-axis motor bracket



- 10 2x M4 T-slot

- 11 2x Bolt M4x20
- 2x Small washer M4

Cable orientation

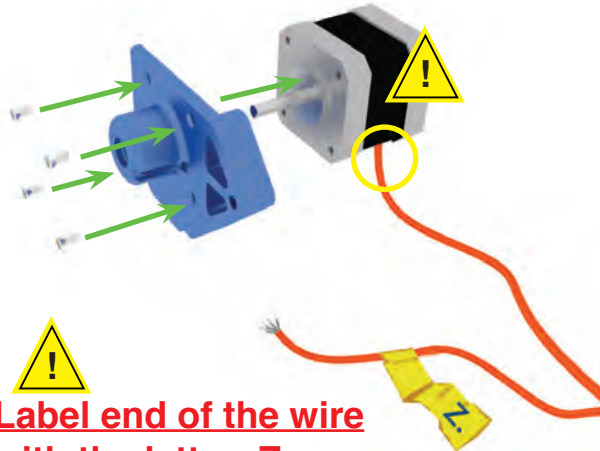

Label end of the wire with the letter: Z

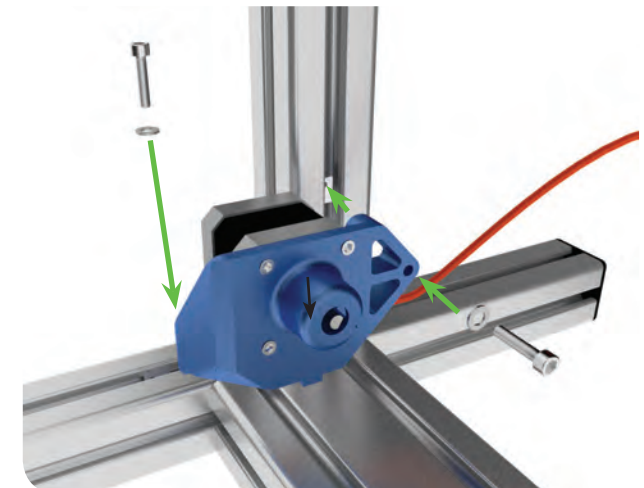

12

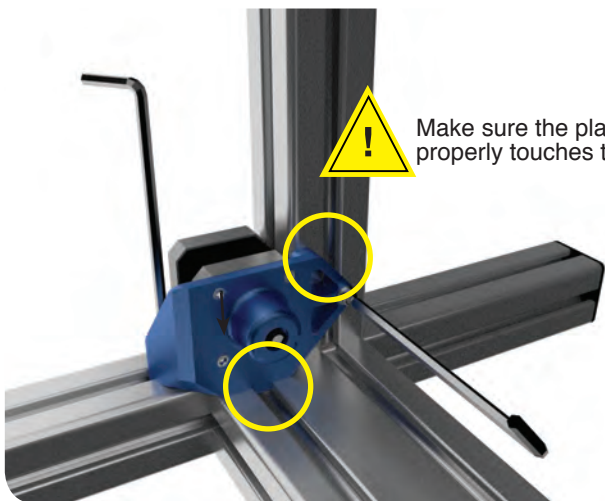

Make sure the plastic part properly touches the frame!

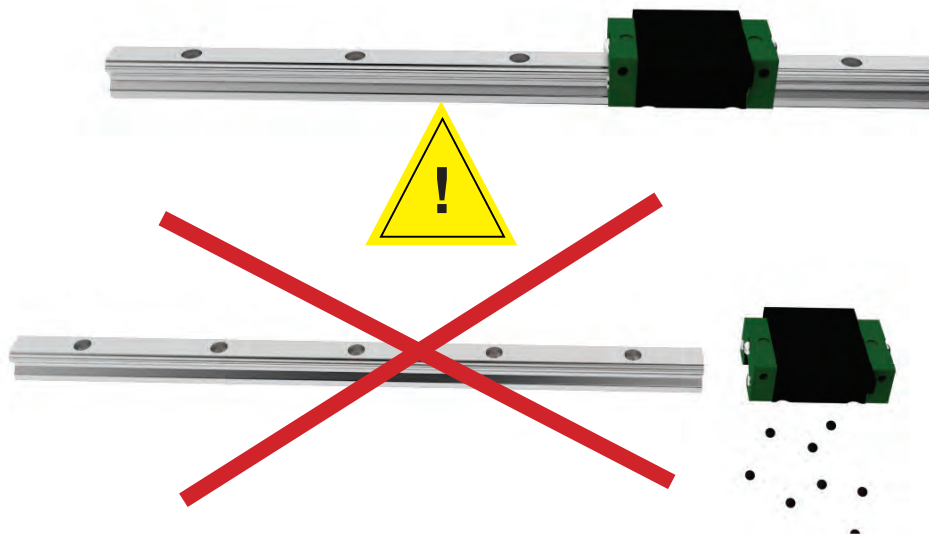

Don't let the cart run off the rail!!

13

- 3x M4 T-slot
- 1x Hiwin linear ball bearing set
HGW15CC1R300Z0
- 3x Bolt M4x20

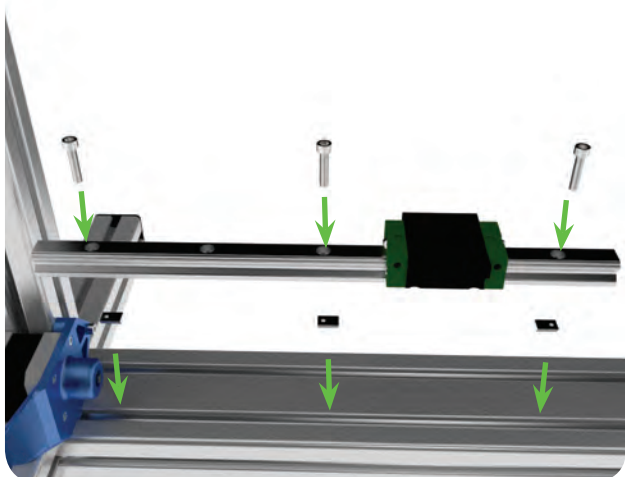

14

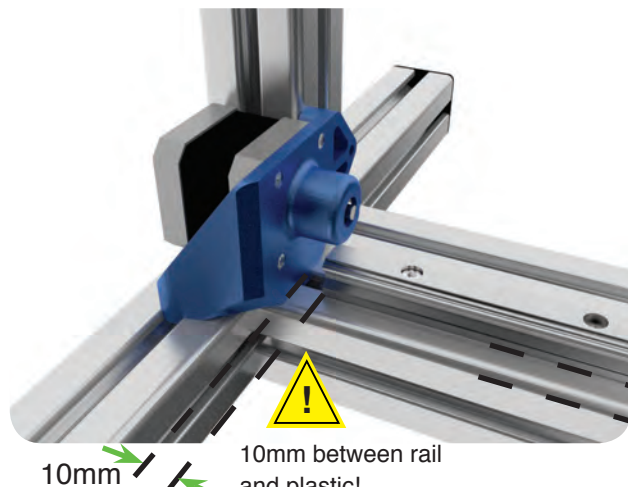

10mm

10mm between rail and plastic!

12mm from side rail to side frame!

15

- 1x Z-axis lift part
- 1x Hexagon nut

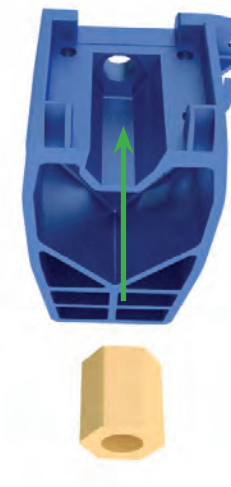

16

2x Bolt M4x40
2x Locknut M4

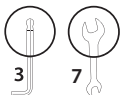

17

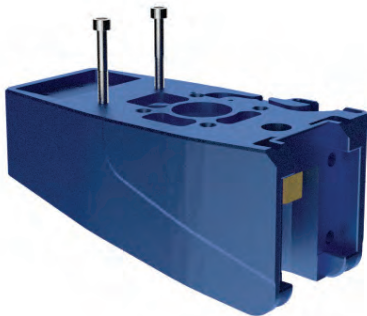

Put the bolts in place in the plastic part by pulling the bolts.

18

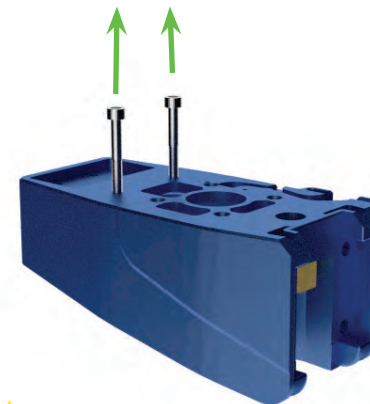

Remove the bolts M4x40

19

2x Bolt M4x25
4x Bearing
2x Small washer M4

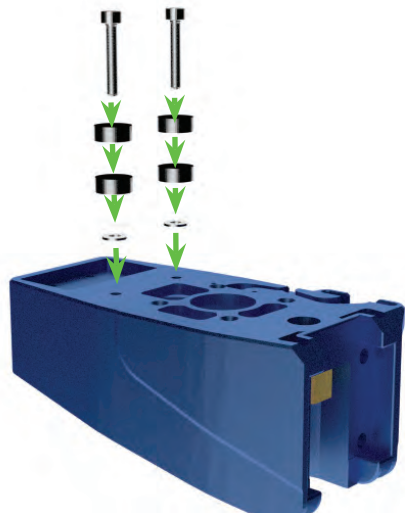

20

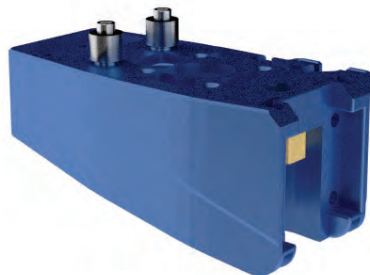

21

4x Bolt M5x16
4x Small washer M5

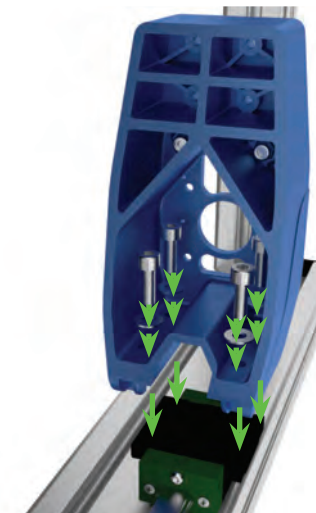
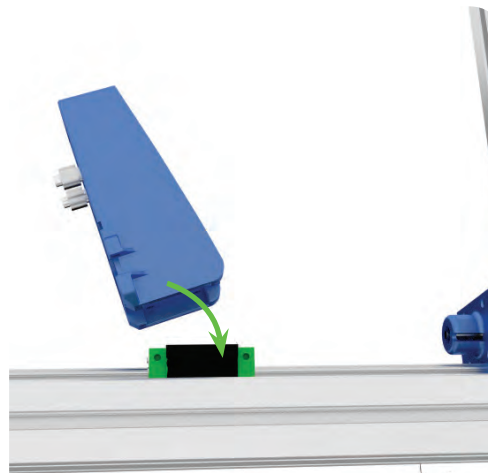

23

4x CSK bolt M3x8
1x Motor

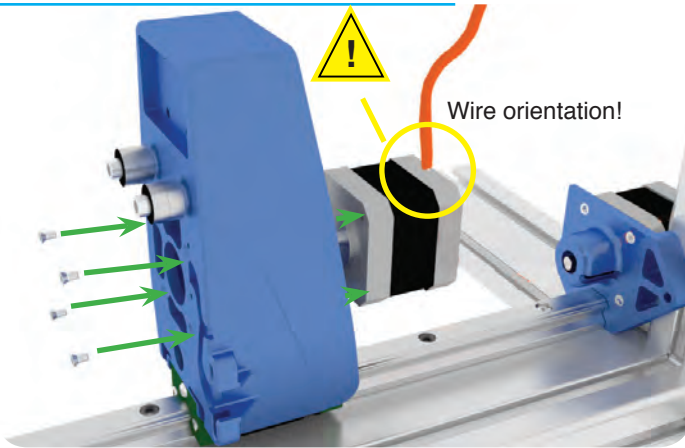

Label end of the wire with the letter: Y

24

1x pulley
1x Set screw M3x6

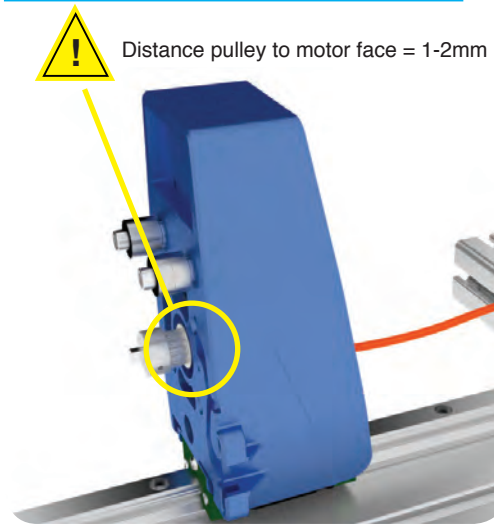

25

1x Spindle

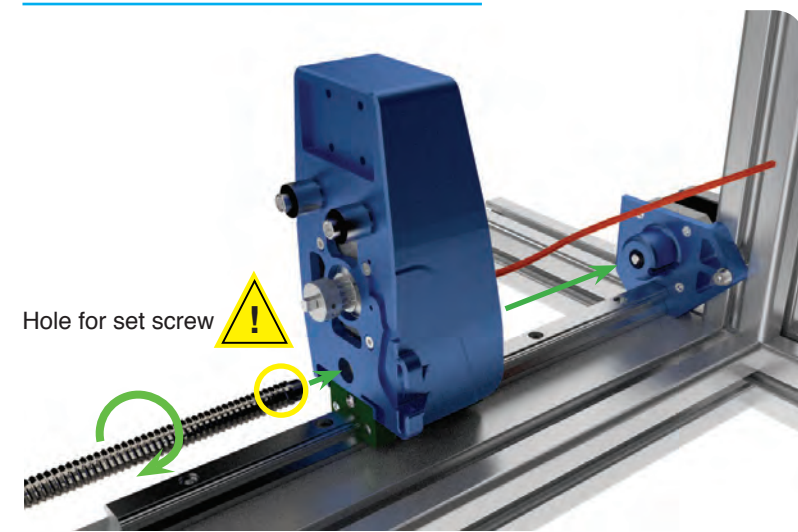

26

1x Set screw M3x6

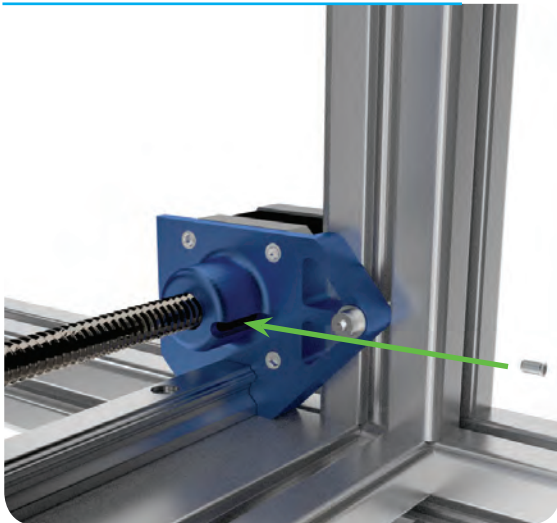

27

1x Z-axis limitswitch vane
1x Bolt M4x25
1x Square nut M4
1x Selflocking nut M4

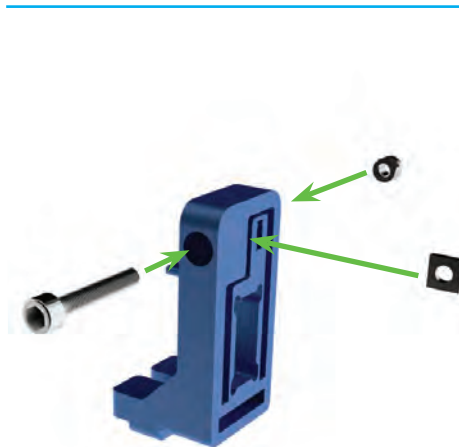

28

1x Bolt M4x20
1x Small washer M4
1x M4 t-slot



Put some grease on the spindle, for example ball bearing grease.

The Z-axis is finished.

Tools:

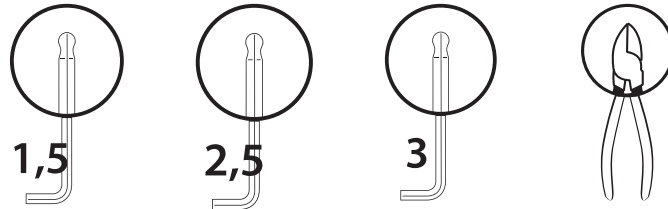

- 29** 1x X stage motor bracket
1x Bolt M4x16
1x Small washer M4
1x T-slot M4

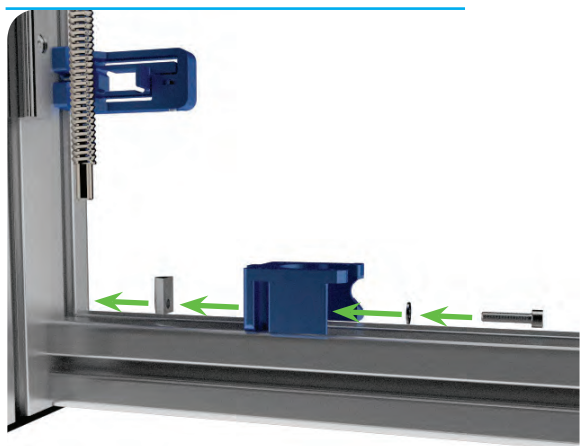

- 30** 1x X stage belt mount
1x Bolt M4x40
5x Small washer M4
2x Large washer M4
1x Bearing

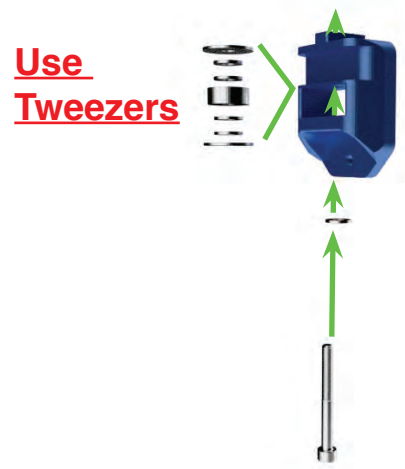

- 31** Belt

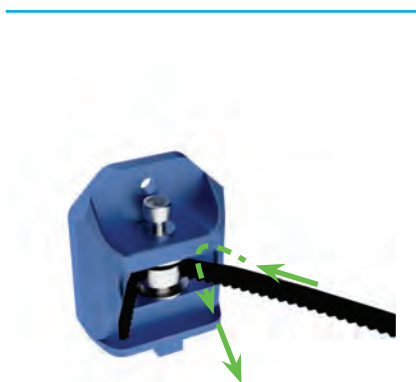

- 32** 1x T-slot M4

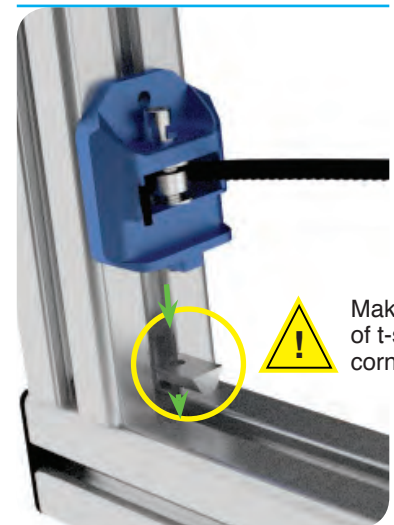

33

- 1x Bolt M4x16
- 1x Small washer M4
- 1x T-slot M4

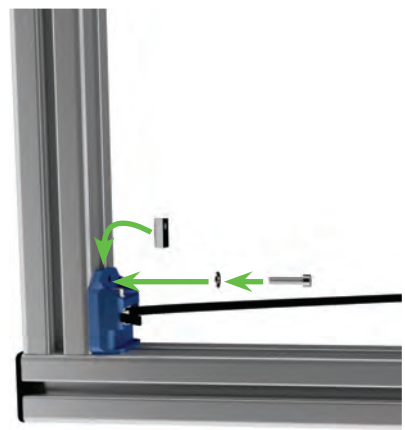
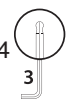

Make sure the plastic is well connected to the frame!

34

- 2x Bolt M3x12
- 1x Hiwin linear ball bearing set HGN12H1R0300Z1HM 2x
- T-slot hammer nut M3

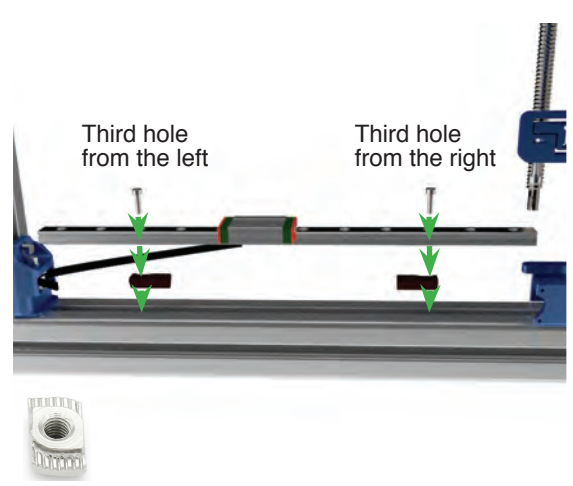

35

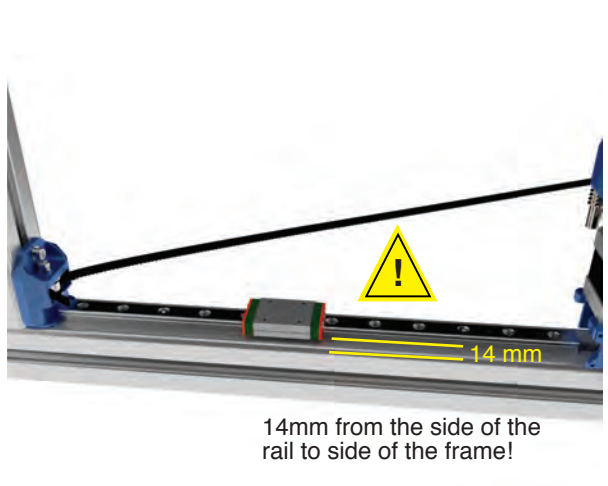

14mm from the side of the rail to side of the frame!



Detail of 35



36

- 1x pulley
- 1x Set screw M3x6

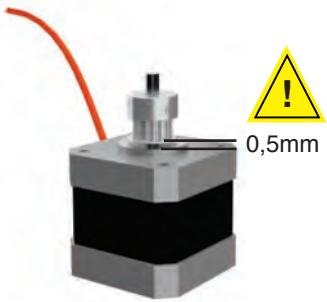
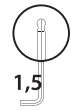

Label the end of the cable: X

37

- 4x CSK bolt M3x8

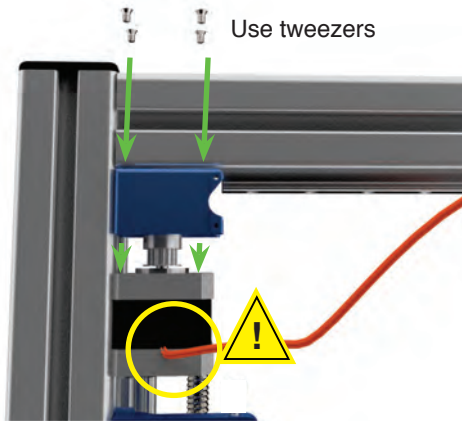
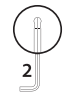

38

- 1x Extruder base
- 4x CSK M3x6

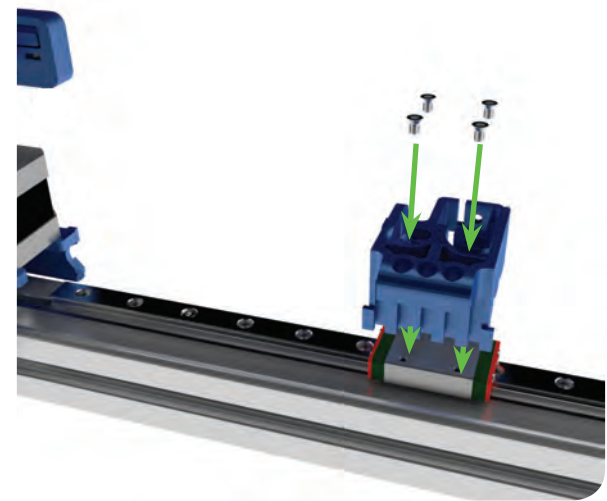

39



Now attach the belt as shown!

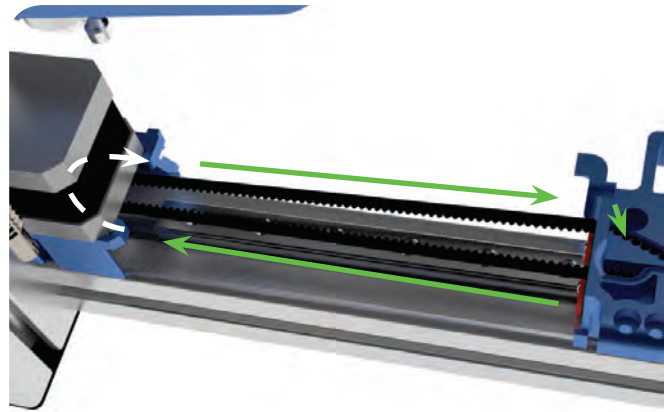
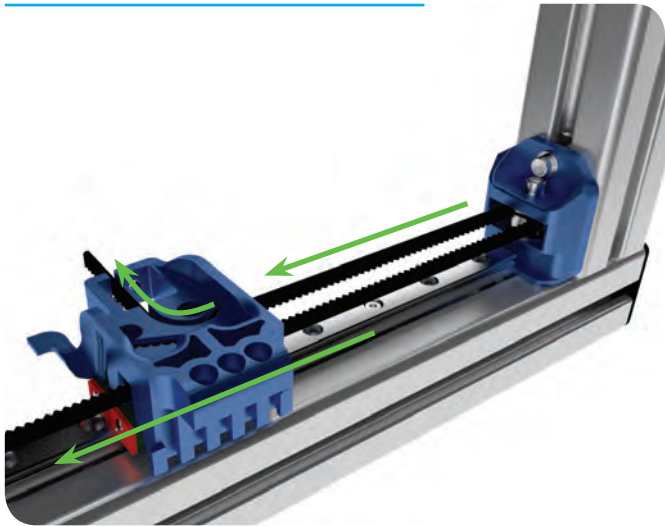

40

- 1x Y stage tensioning bracket
- 1x Thin nut M4
- 1x Bolt M4x25

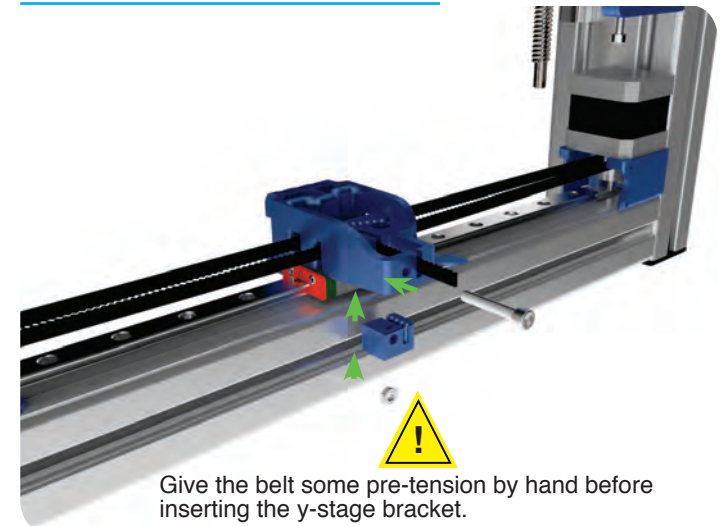

41

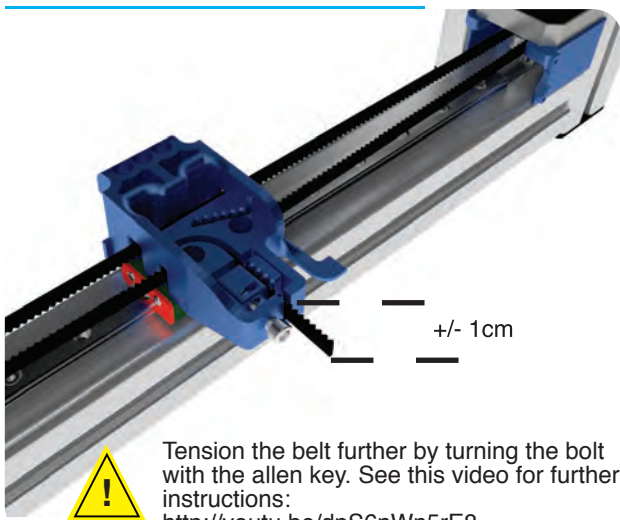
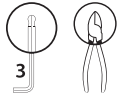

The X-axis is finished.

Tools:

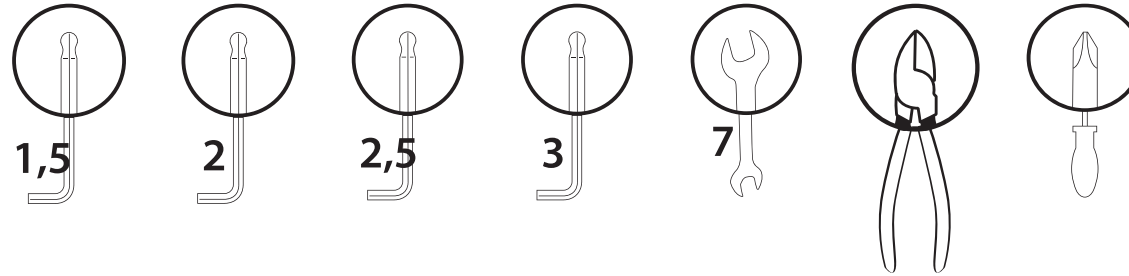

For Single extruder continue at the next page.

For Dual extruder start at page 18



42

- 1x Bolt M4x12
- 2x Large washer M4
- 1x Spring
- 1x Thin nut M4

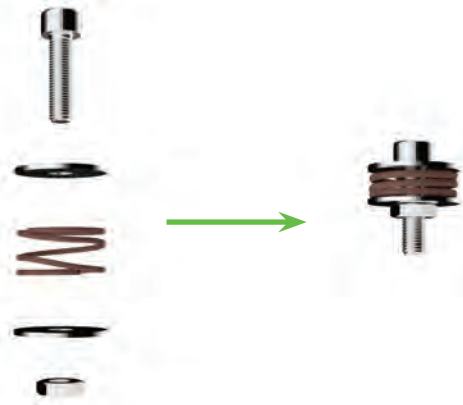
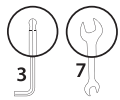

43

- 1x Extruder arm pt1
- 1x Extruder arm pt2
- 3x Bolt M3x16

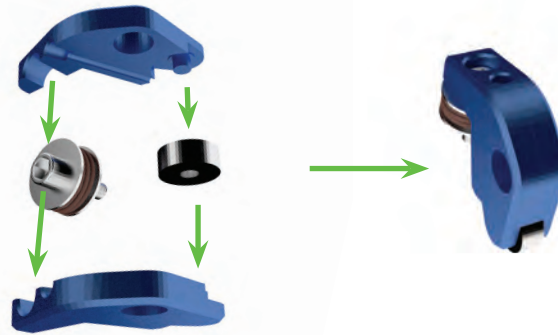

44

- 1x Extruder wheel
- 1x Set-screw M3x4

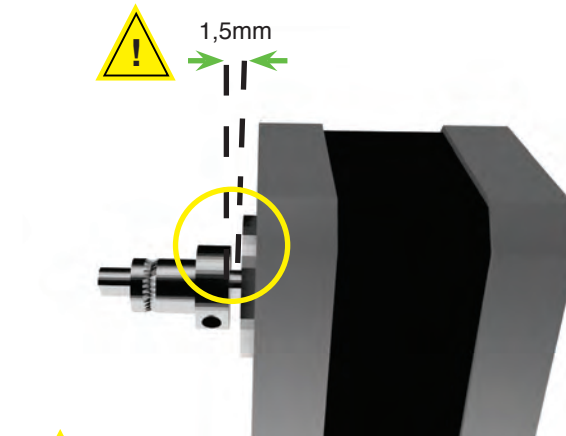

Label end of the wire: Ext 0

45

- 1x Extruder L shape bracket
- 1x Square nut M4

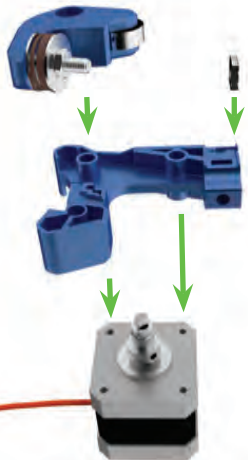

46

- 1x Extruder L shape bracket
- 3x Bolt M3x30

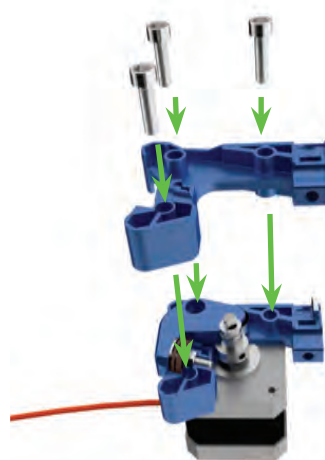

47

- 1x Extruder air duct
- 1x extruder hot-end clamp
- 3x Thin nut M4
- 3x Bolt M4x20
- 1x Fan

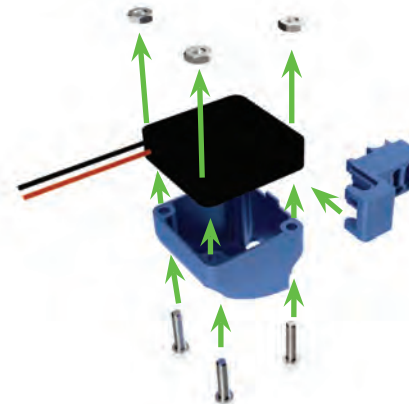
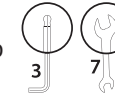

Make sure the sticker of the fan is on the bottom, the fan blows in the direction of the sticker.

Label end of the wire: 1

48

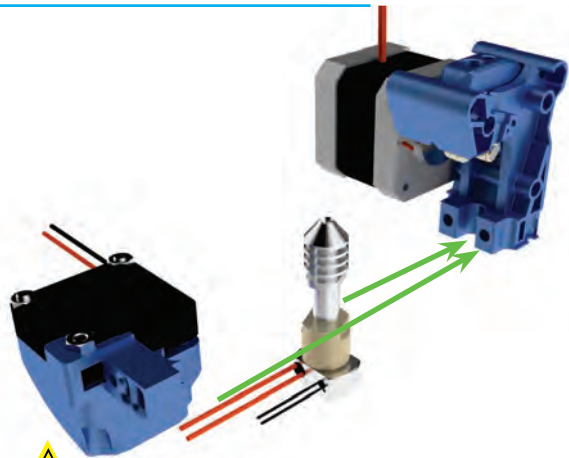

! Label end of the hot-end cable: 0

49

1x Thin square nut M4
1x Bolt M4x40

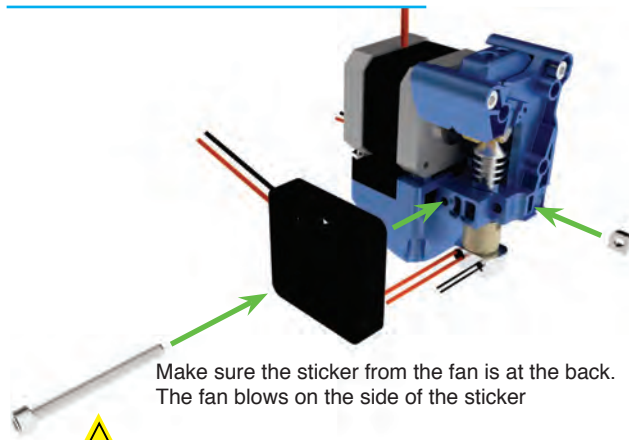

Make sure the sticker from the fan is at the back.
The fan blows on the side of the sticker

Mount the bolt loosely, fasten tight at step 52



! Label end of the wire: 2

50

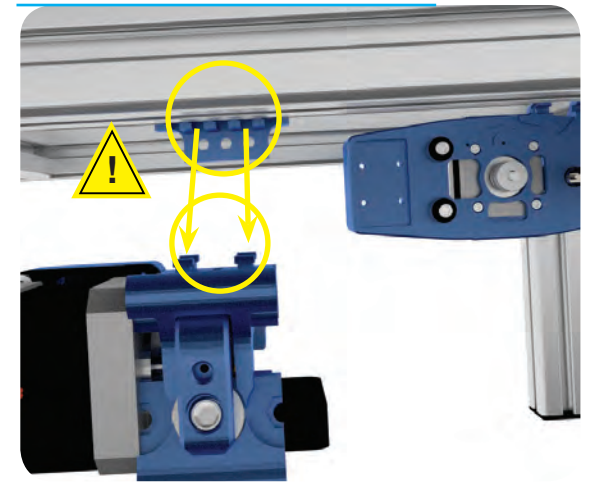

Align the print head on the carrier

51

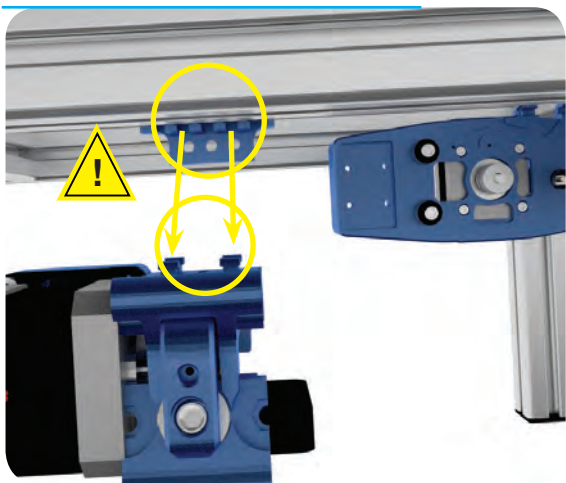

Align the print head on the carrier

52

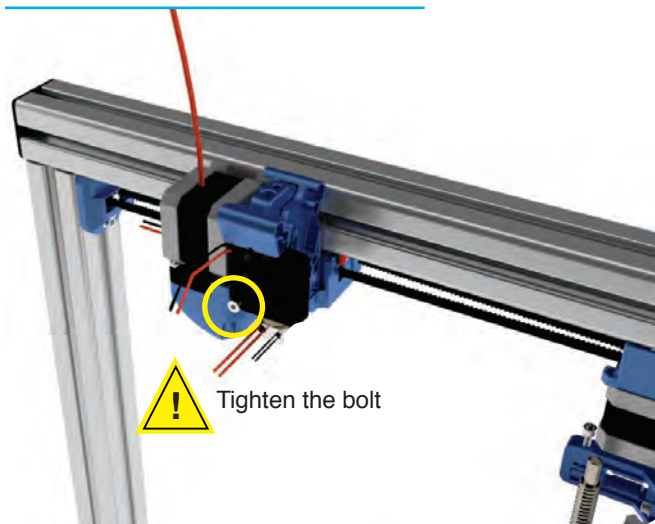

! Tighten the bolt

54

1x Bolt M4x12

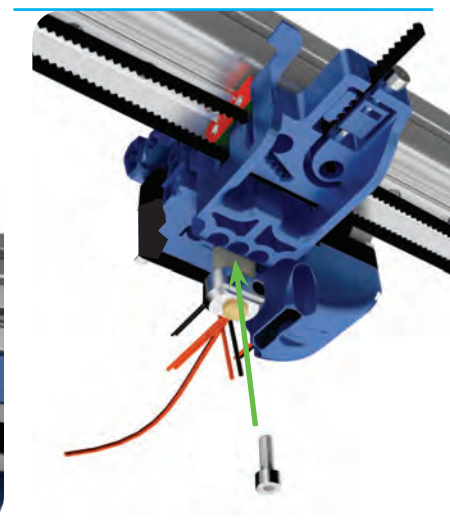

**Goto step 55
at page 22**

42

- 1x Bolt M4x12
- 2x Large washer M4
- 1x Spring
- 1x Thin nut M4

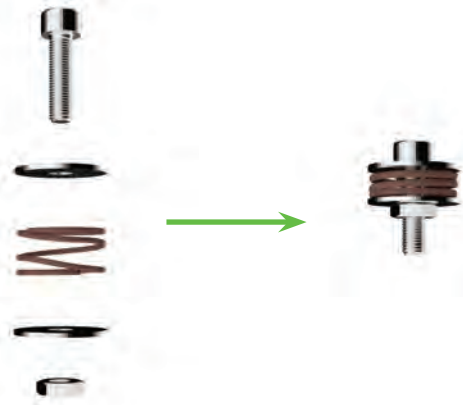
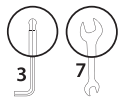

43

- 1x Extruder arm pt1
- 1x Extruder arm pt2
- 3x Bolt M3x16

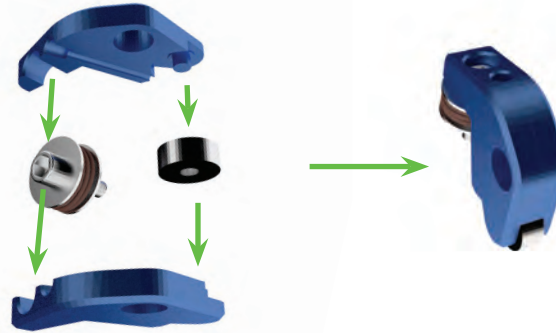

44

- 1x Extruder wheel
- 1x Set-screw M3x4

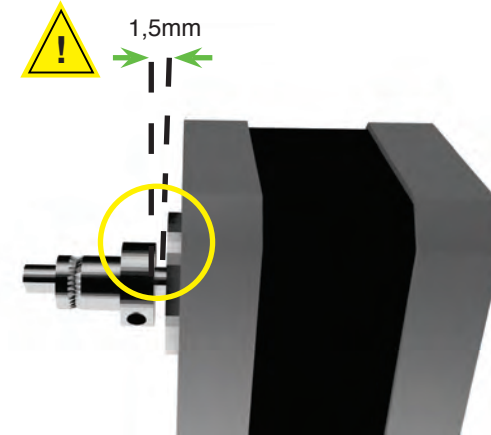

repeat these steps

45

- 3x Bolt M3x16
- 1x L-shaped bracket

45a

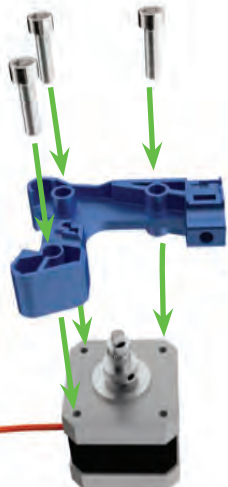

Label end of the wire: 0

46

- 3x Bolt M3x16
- 1x L-shaped bracket

46a

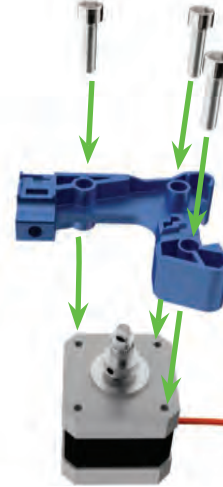

Label end of the wire: 1

47

1x Square nut M4

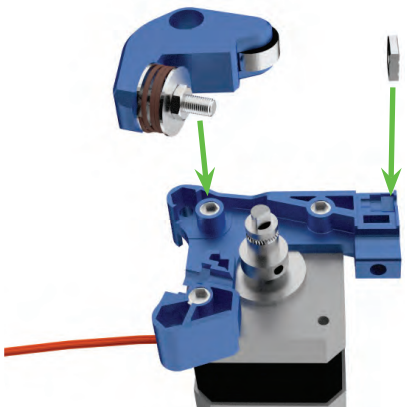

47^a

1x L-shaped bracket

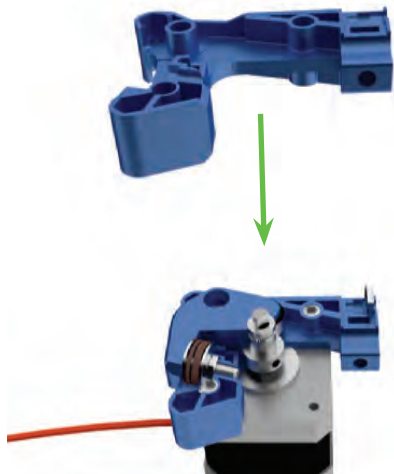

47^b

1x Square nut

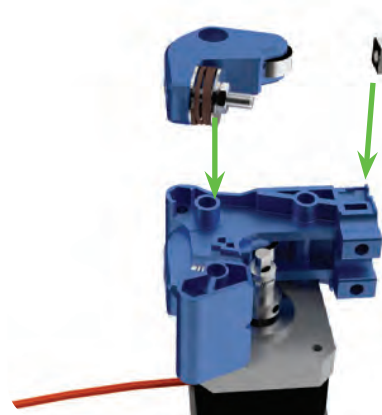

47^c

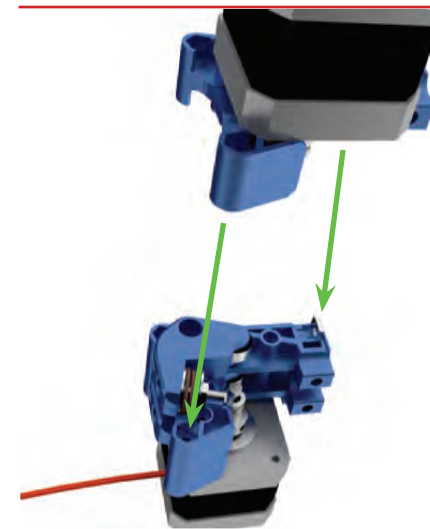

48

2x Selflocking nut M4
2x Bolt M4x40

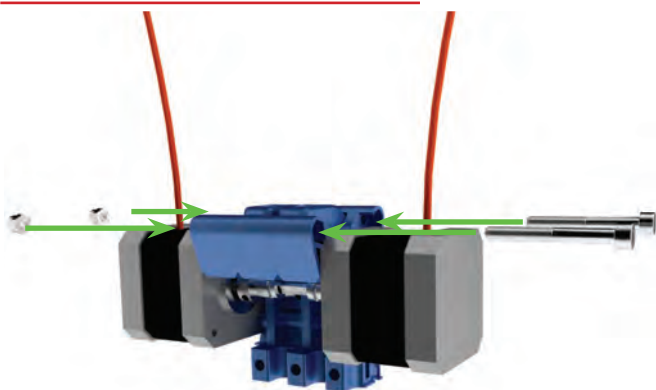

48^a



49

1x Dual_Extruder_Clamp
1x Dual_Extruder_Mover
1x Hexagon M3 x 35
1x Selflocking Nut M3



49

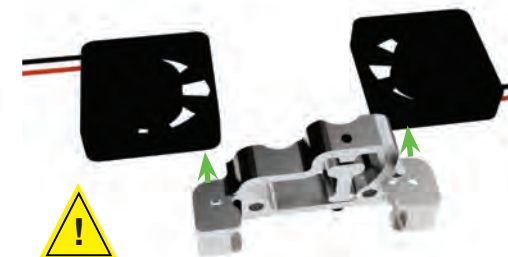

Mount the bolt loosely, lock tightly at step 52a



Make sure the sticker from the fan is on the bottom. The fan blows on the side of the sticker

Label end of the wires: 1

49^A

6x Thin nut M4
6x Bolt M4x20

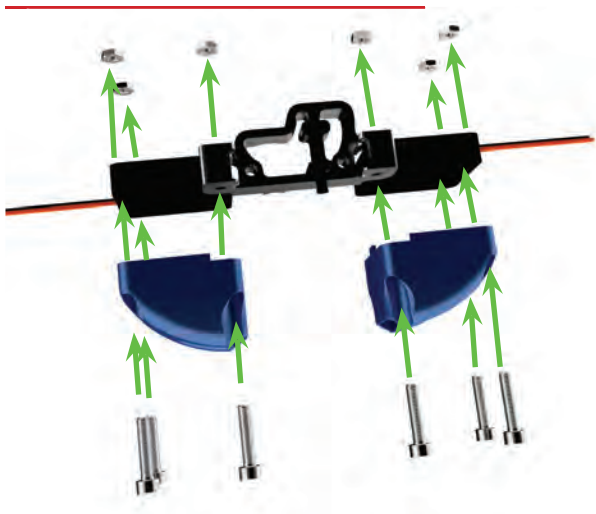
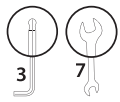

50

2x Thin nut M4

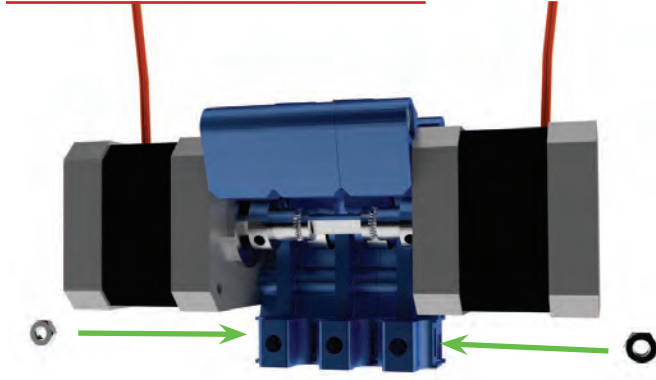

51

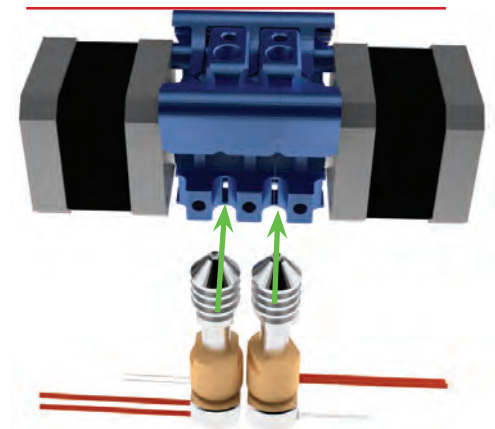

Label end of the left hot-end cable: 0
Label end of the right hot-end cable: 1

51^A

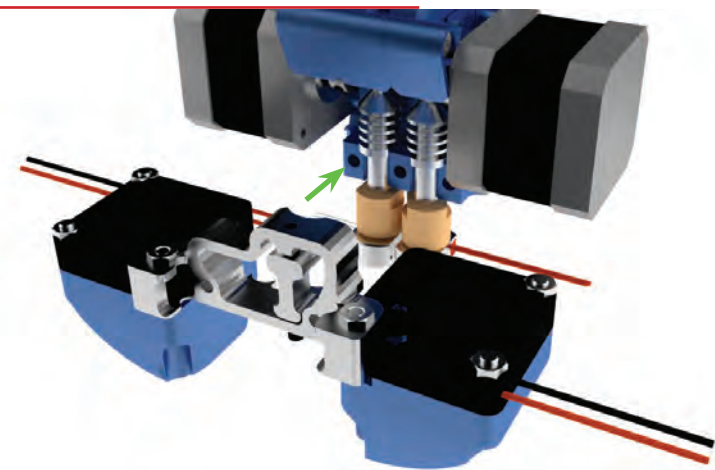

51^B

2x Bolt M4x40

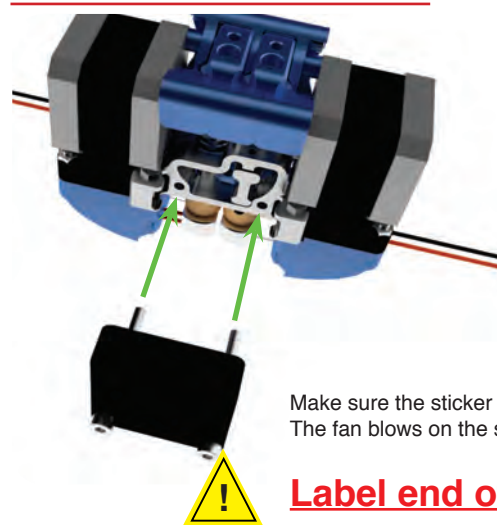

Make sure the sticker from the fan is at the back.
The fan blows on the side of the sticker

Label end of the fan-wire: 2

51^C

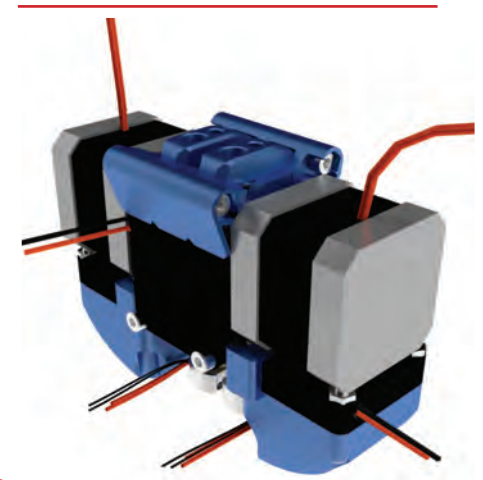

52

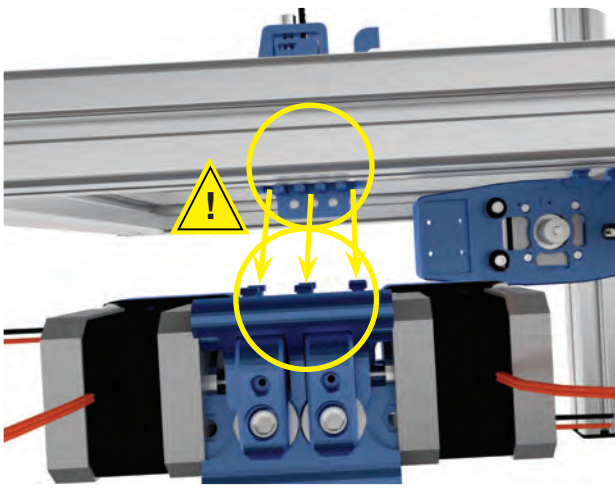

Align the printhead on the carrier

52^A

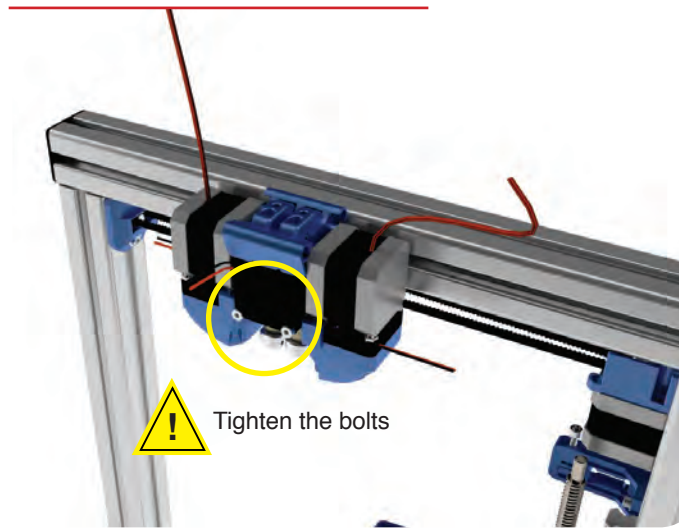

Tighten the bolts

53

2x Bolt M4x12

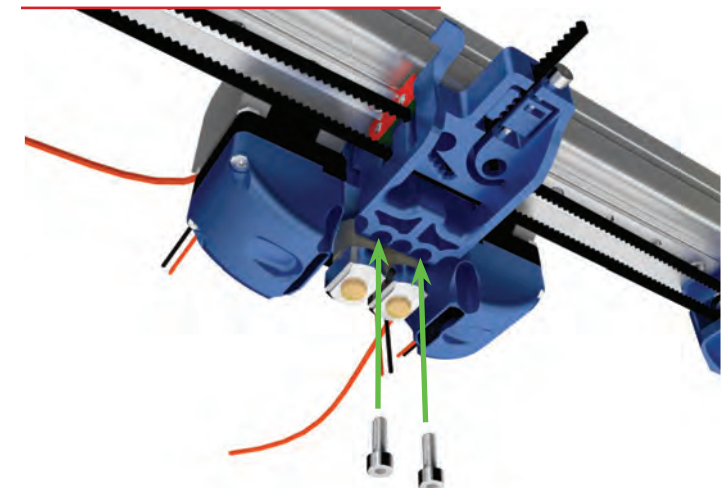

54

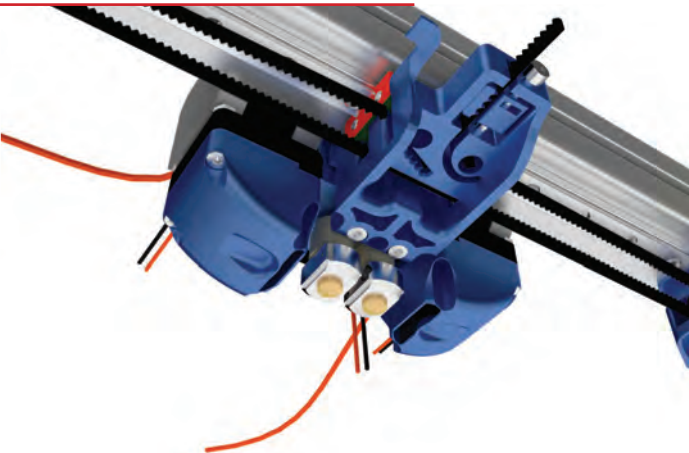

55

2x Small screw 2,2 x 8
Opto sensor straight cable

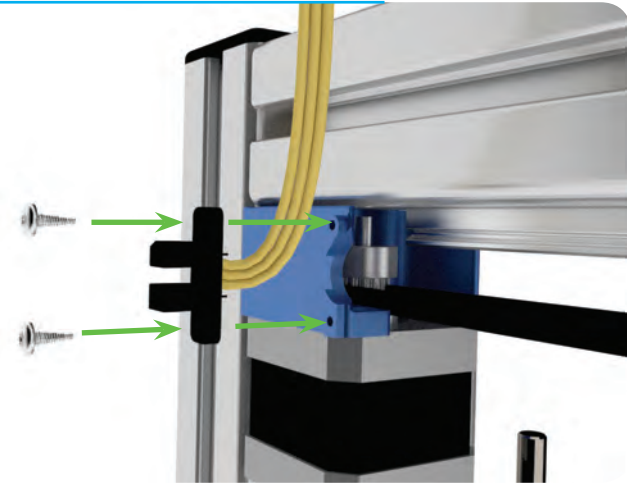

Label end of the wire: X

56

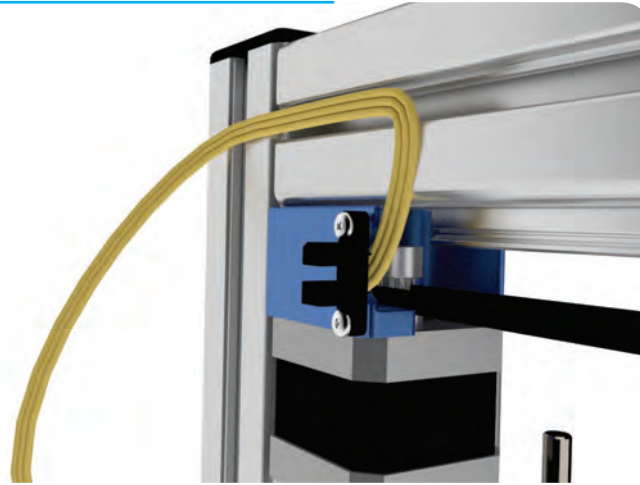

57

2x Power supply screw
Opto sensor straight cable

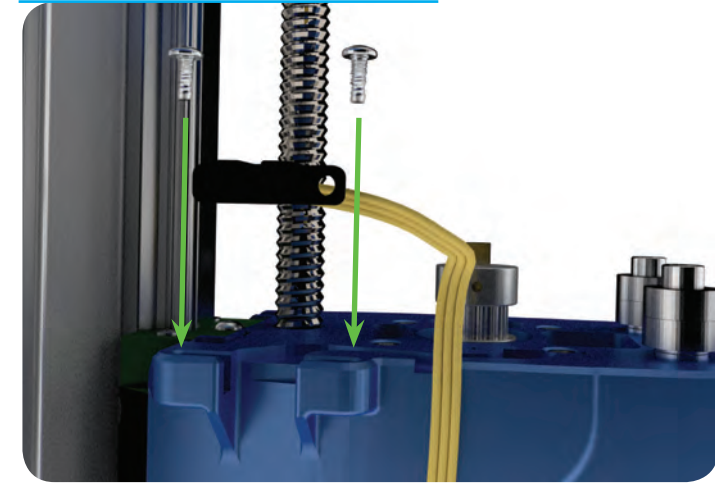

Label end of the wire: Z

58



2x Small screw 2,2 x 8
2x Thin nut M4
Opto sensor angled cable



Label end of the wire: Y

59



The extruder is finished.

Tools:

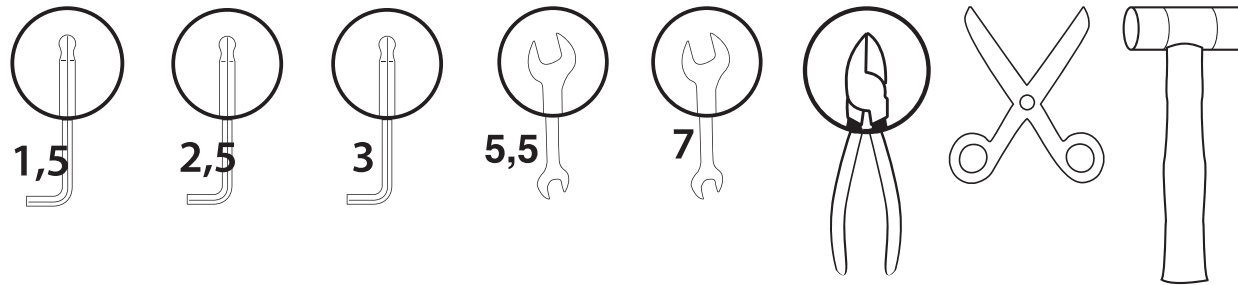

60

- 1x Y-stage bracket pt1
- 1x Y-stage bracket pt2
- 4x Bolt M3x16
- 4x Small washer M3
- 4x Self locking nut M3

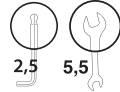

63



64

- 1x Bolt M3x8
- 1x Small t-slot M3

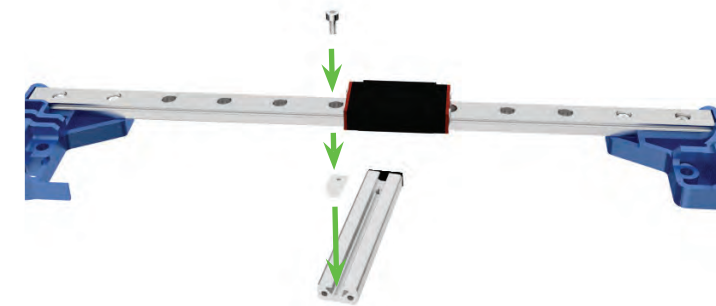

65

1x Y stage tensioning bracket
1x Thin nut M4
1x Bolt M4x25

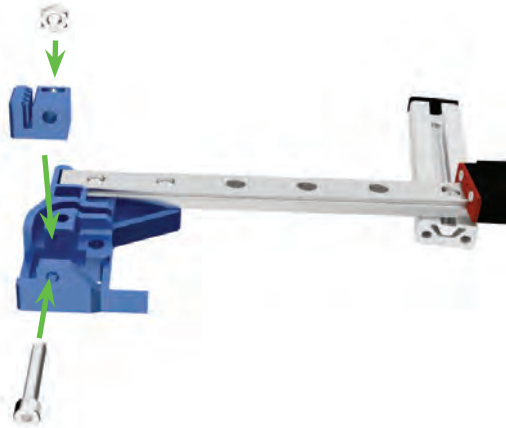

66



67

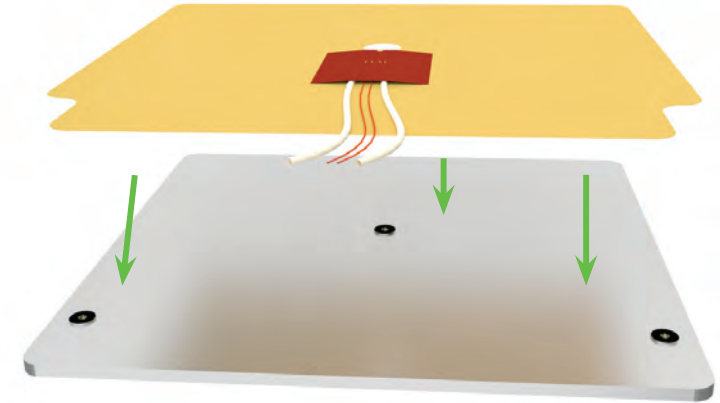

68



69

3x Set screw M4x30
3x Thin nut M4

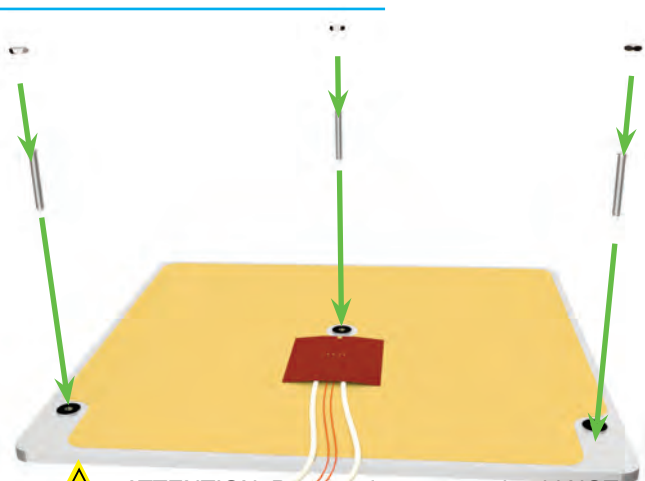

ATTENTION: Bottom of set-screw should NOT touch plate internally. Keep distance of approx. 0.5mm

70

3x spring
2x Small washer
1x Large washer
3x Thin nut M4

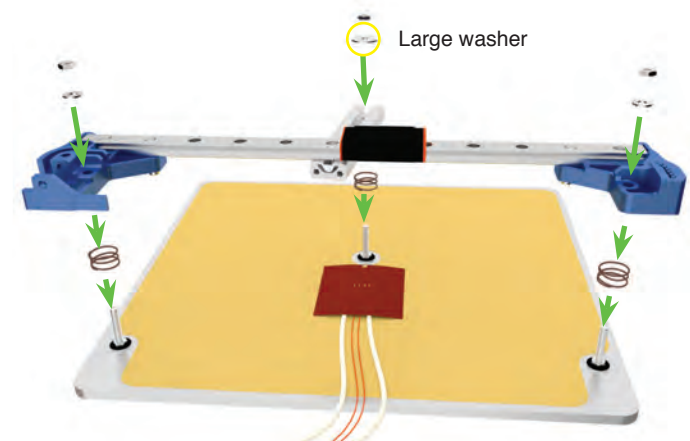

71

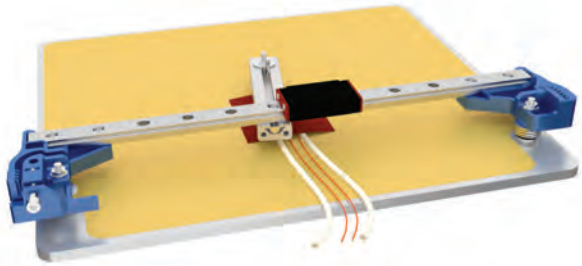

Tighten the nuts a couple of turns, make sure that the springs are still able to compress for further fine-adjustment later.

72

2x tie-wrap

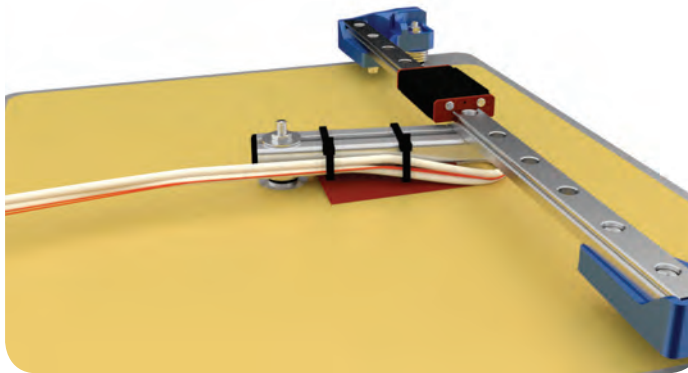

73

1x 25 cm Cable spiral

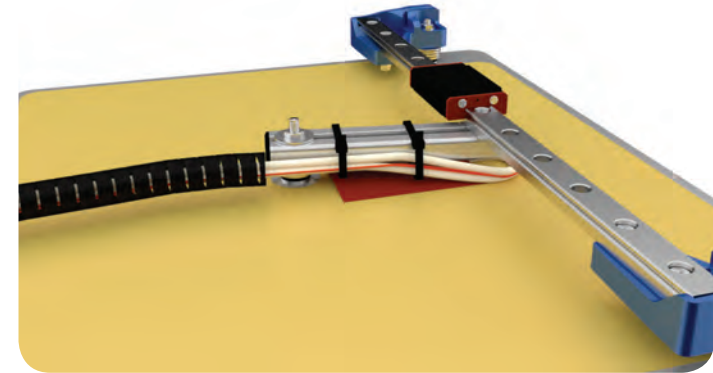

74

4x Bolt M3x16
4x Small washer M3

75



76

Belt

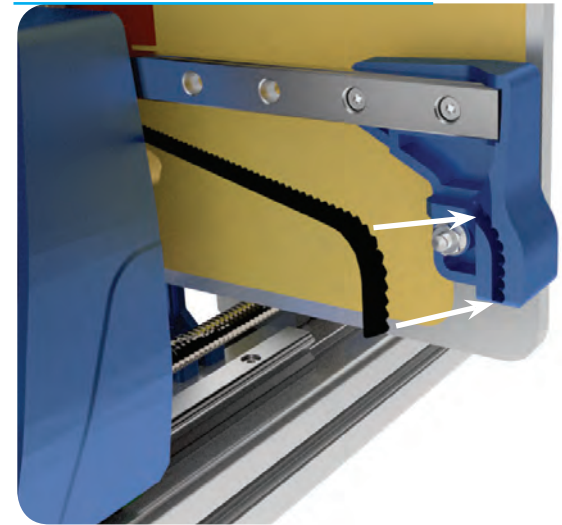
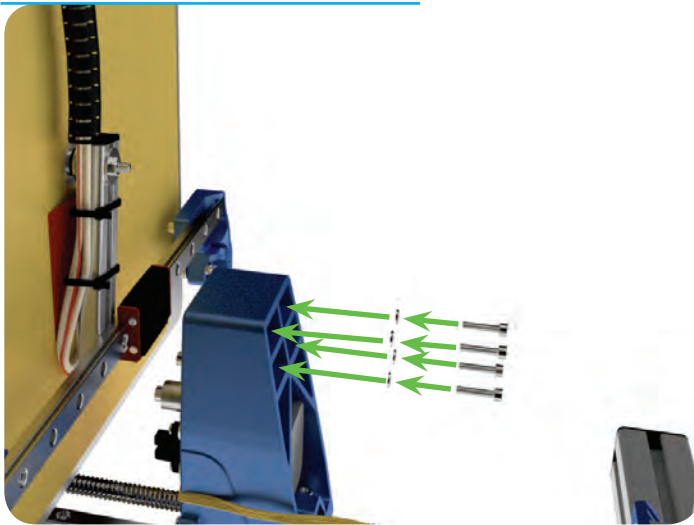

77

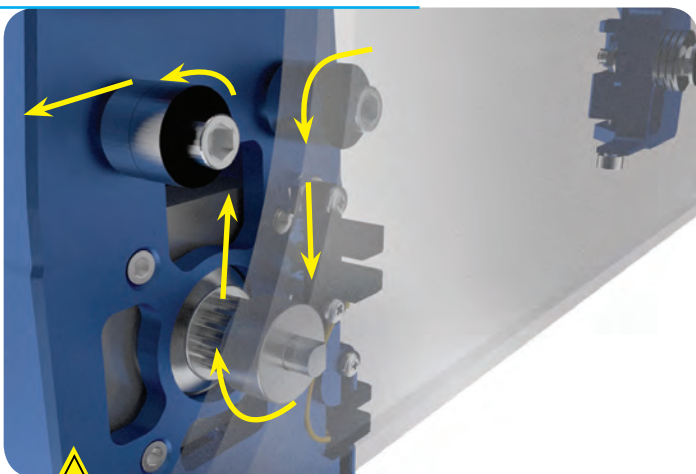

Mount the belt, according to the arrows.

78

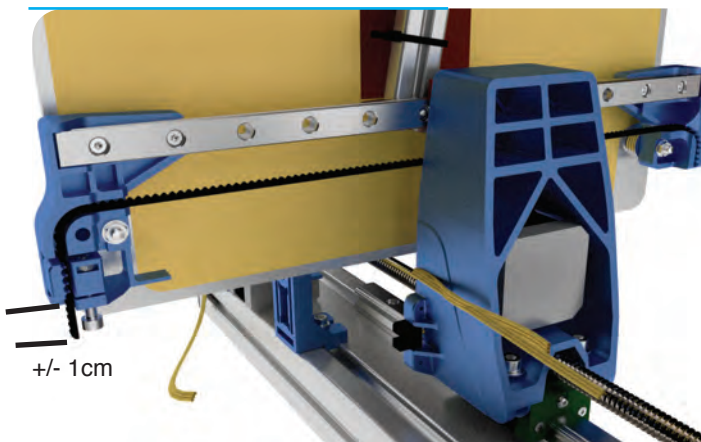
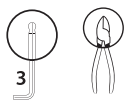

Tension the belt further by turning the bolt with the allen key. See this video for further instructions: <http://youtu.be/dpS6nWn5rE8>

79

1x 25 cm Cable spiral
1x Clamp + Cable tie

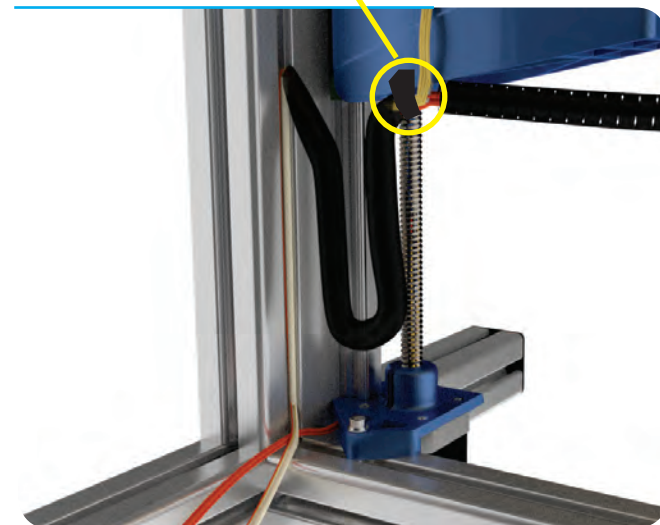

80

1x 13 cm Plastic U-profile



Ends of the plastic strip must be cut at an angle

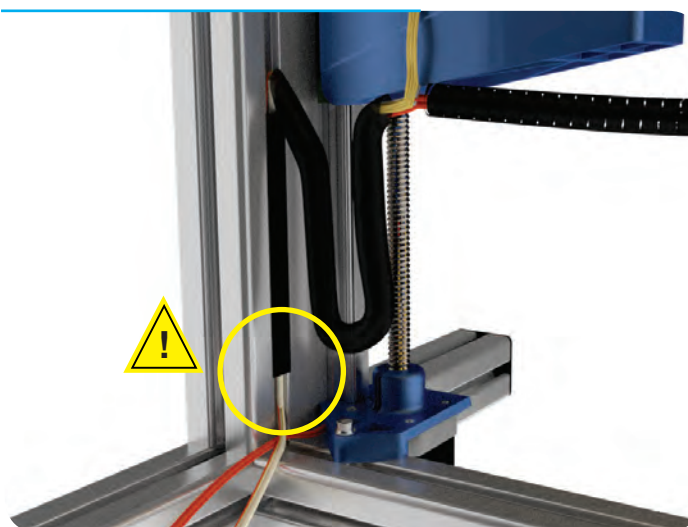

The y-axis and the print bed are finished.

Tools:

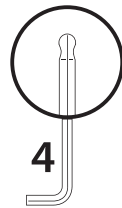

- 81** 2x T-slot M5
1x Handle
2x Bolt M5x12
1x Handle-cap



- 82**

- 83** 6x Damping feet

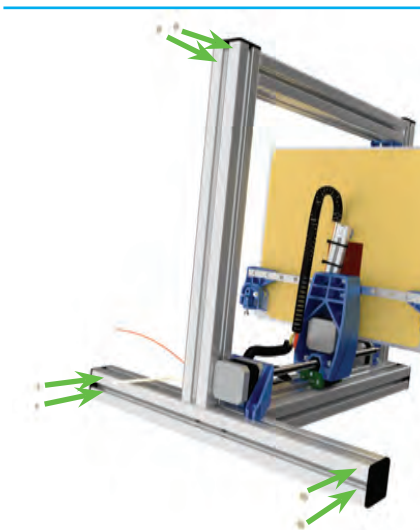
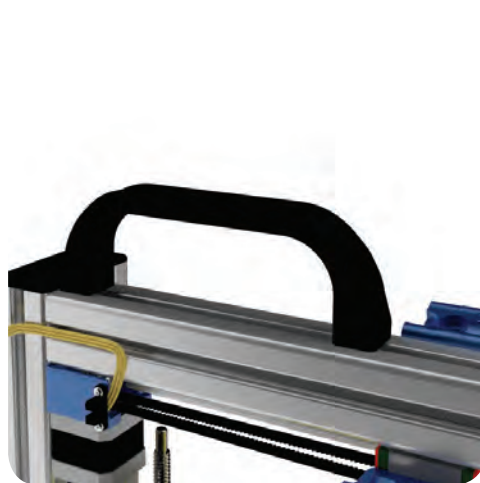
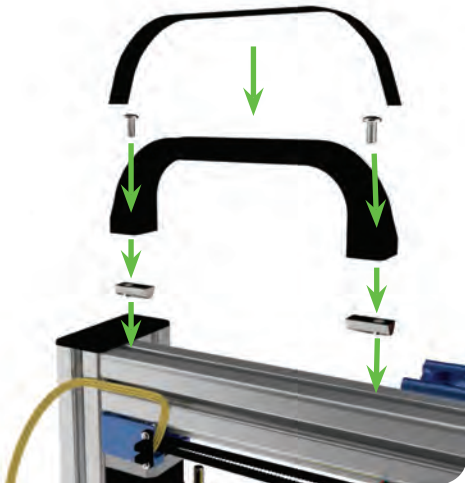

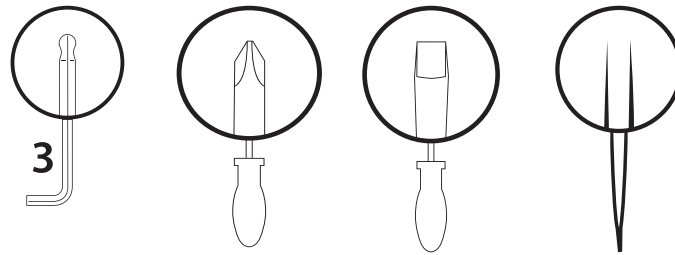

The handle is finished.

Tools:

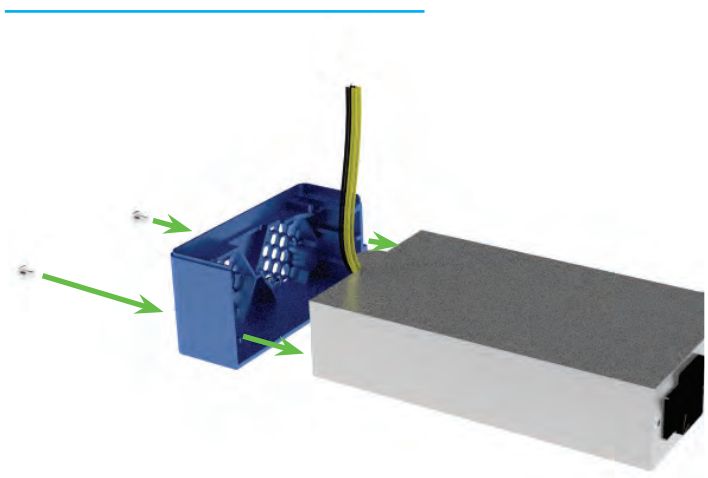

84 1x Electronics enclosure pt2
2x Power supply screw 



85 1x Electronics enclosure pt1
2x Power supply screw 

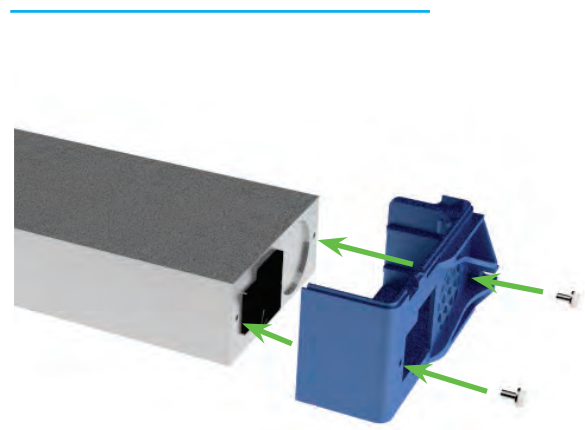

86

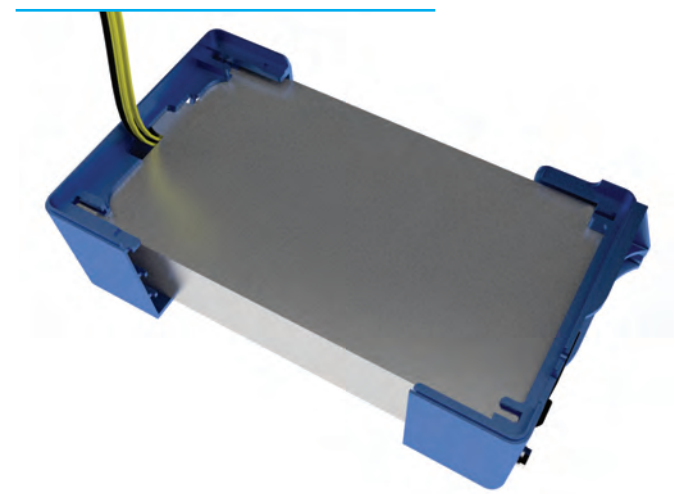

87

1x Electronics enclosure cover plate

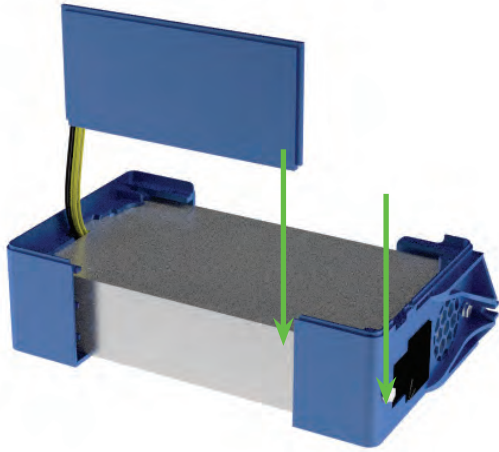

88

4x Thin square nut M4

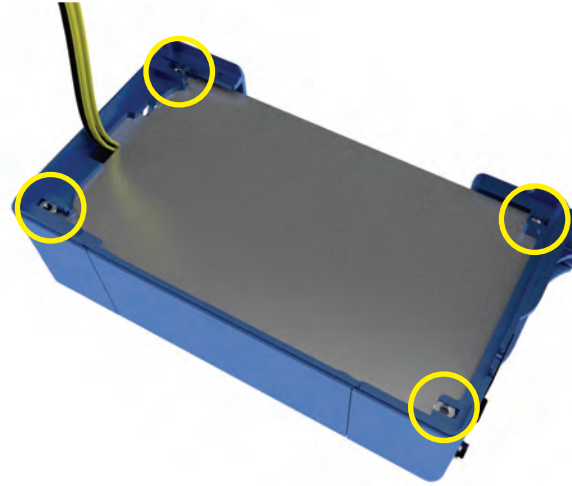

89

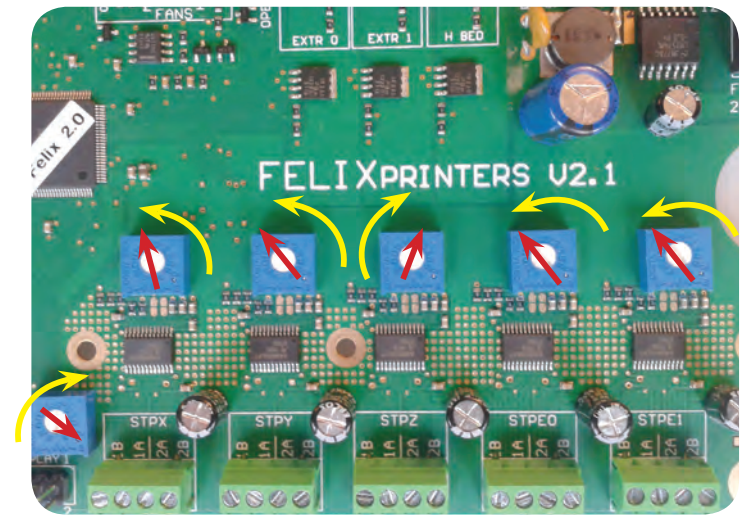

90

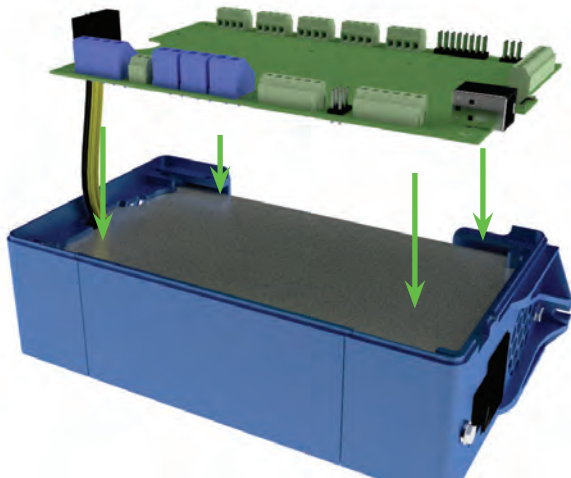

91

2x Bolt M4x12
2x Small washer M4
2x T-slot M4

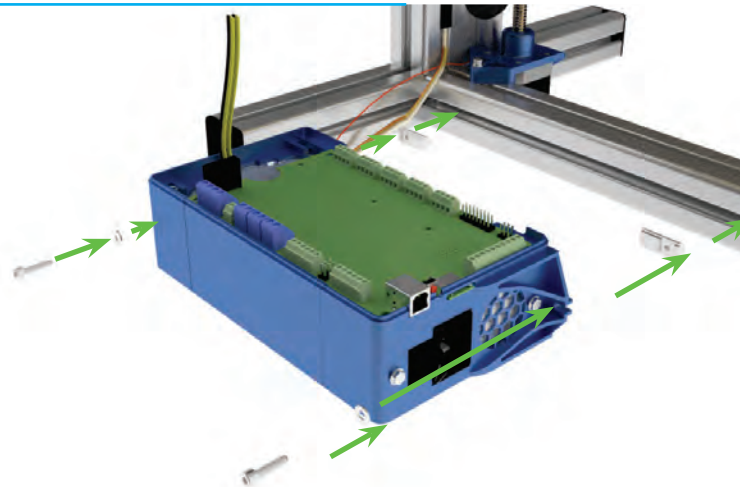

92

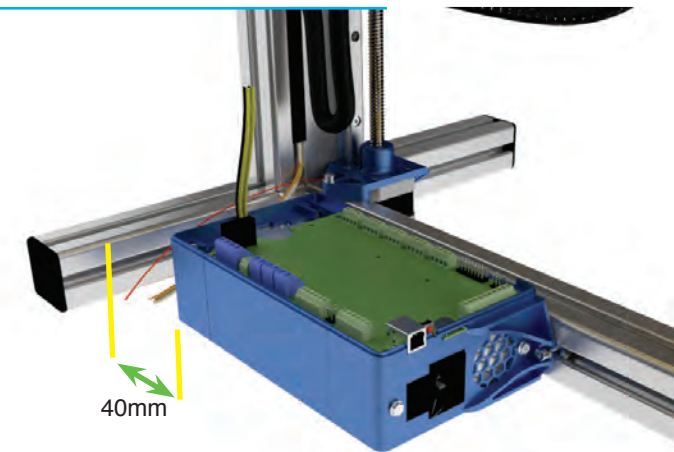

Tools:

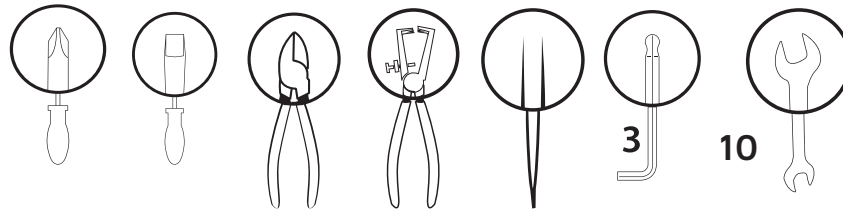

Next steps are shown based on the double-extruder. For a single extruder you only need to connect the existing cables.

93

1x cable tie sticker
2x cable tie sticker

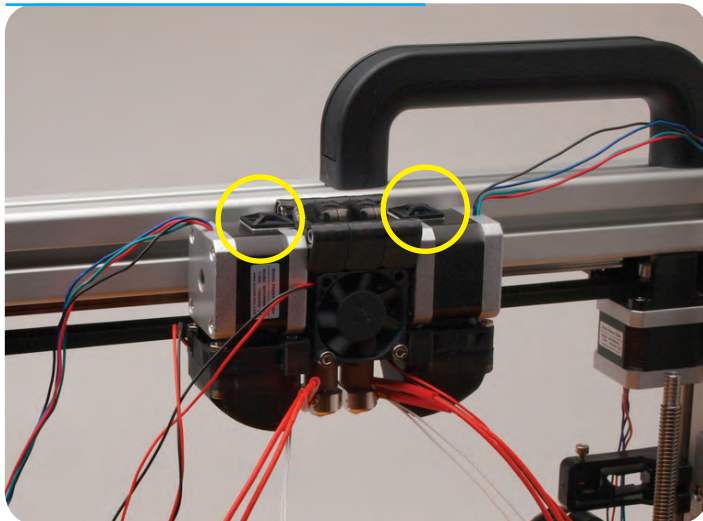

94

2x cable tie
2x cable tie

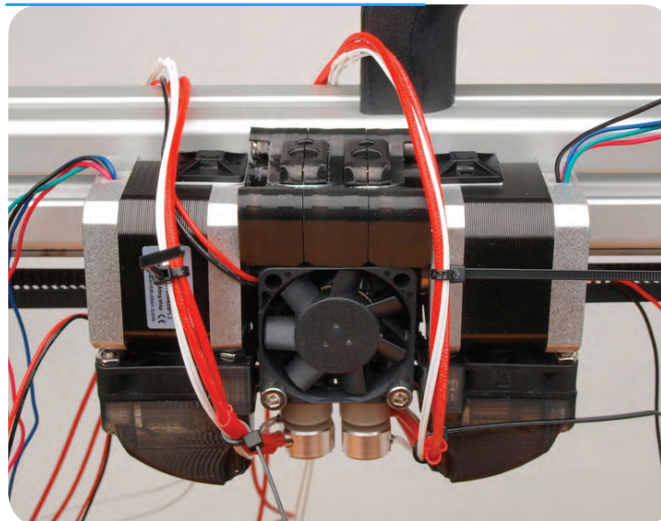

95

1x cable tie
2x cable tie

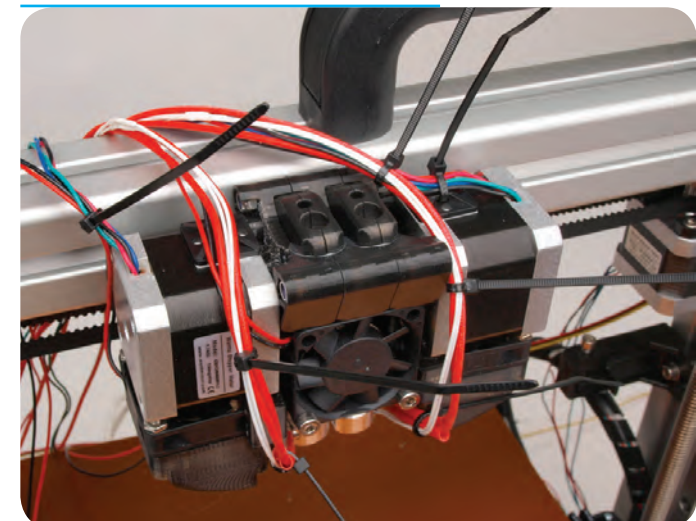

96

2x cable tie

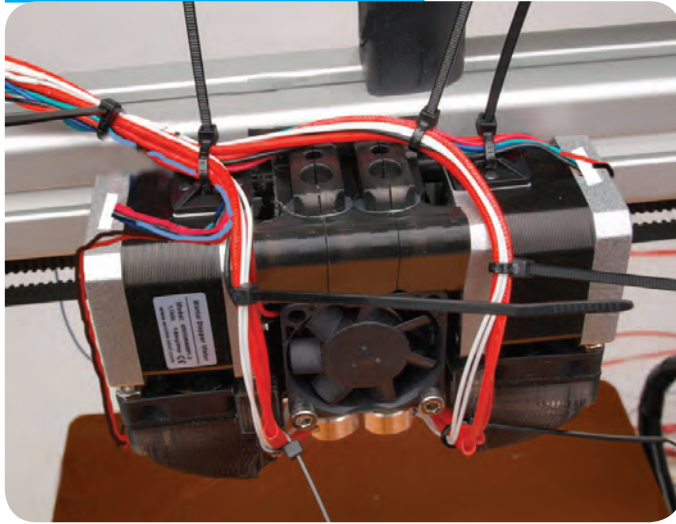

97

25cm cable spiral



98

1x 15cm strip
1x 2cm strip
1x 6 cm strip

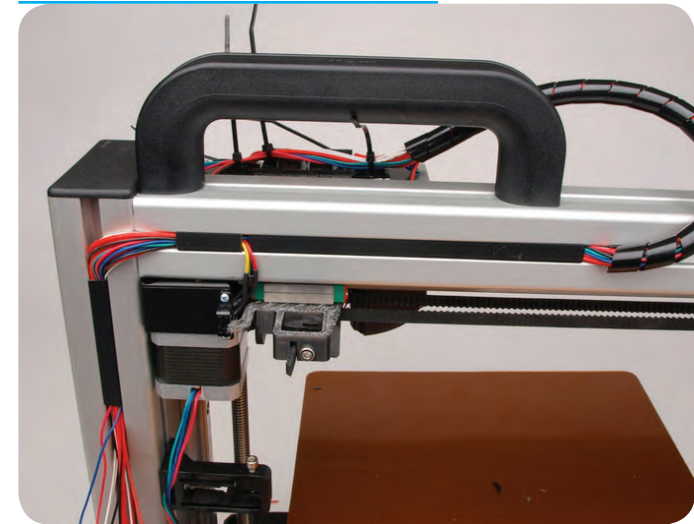

99

1x 28cm strip
4x cable ties

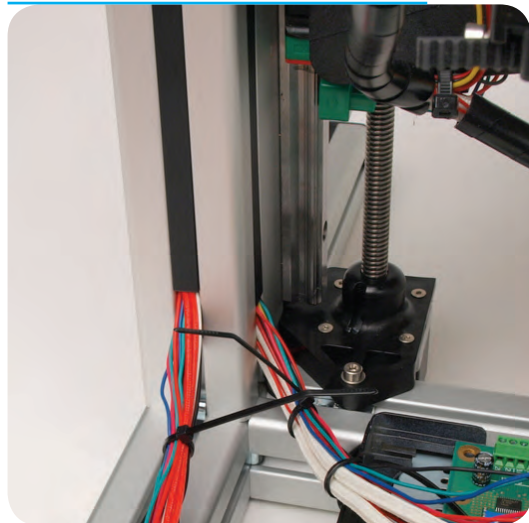

The following steps are to connect the cables to the electronic-board.



ATTENTION! The electronics are sensitive to static electricity!





Strip the ends of the cable

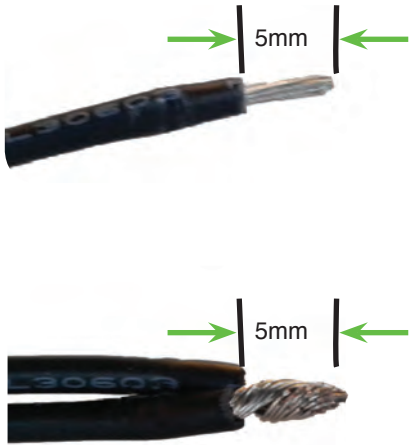

101

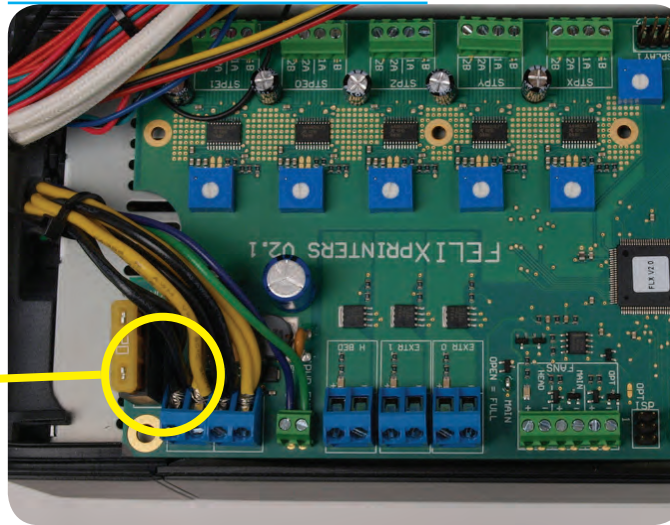
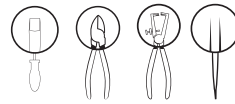

102

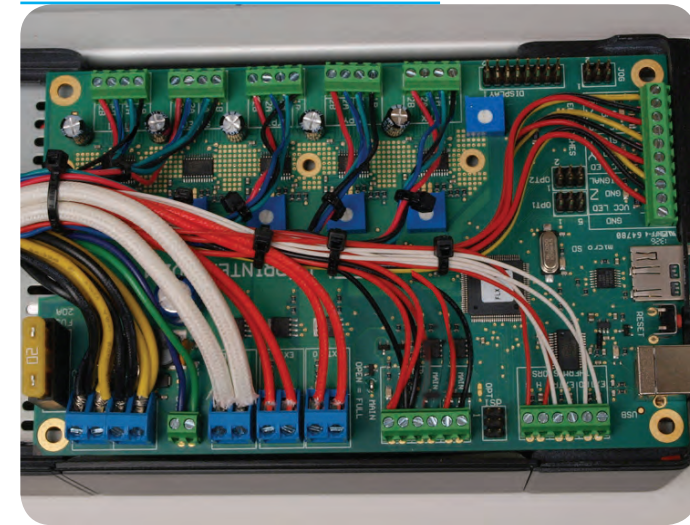
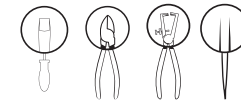

103

1x 15 cm Cable spiral



Wire diagram Single-head: page 33

Wire diagram Dual-head: page 34



Wiring diagram for the single extruder.

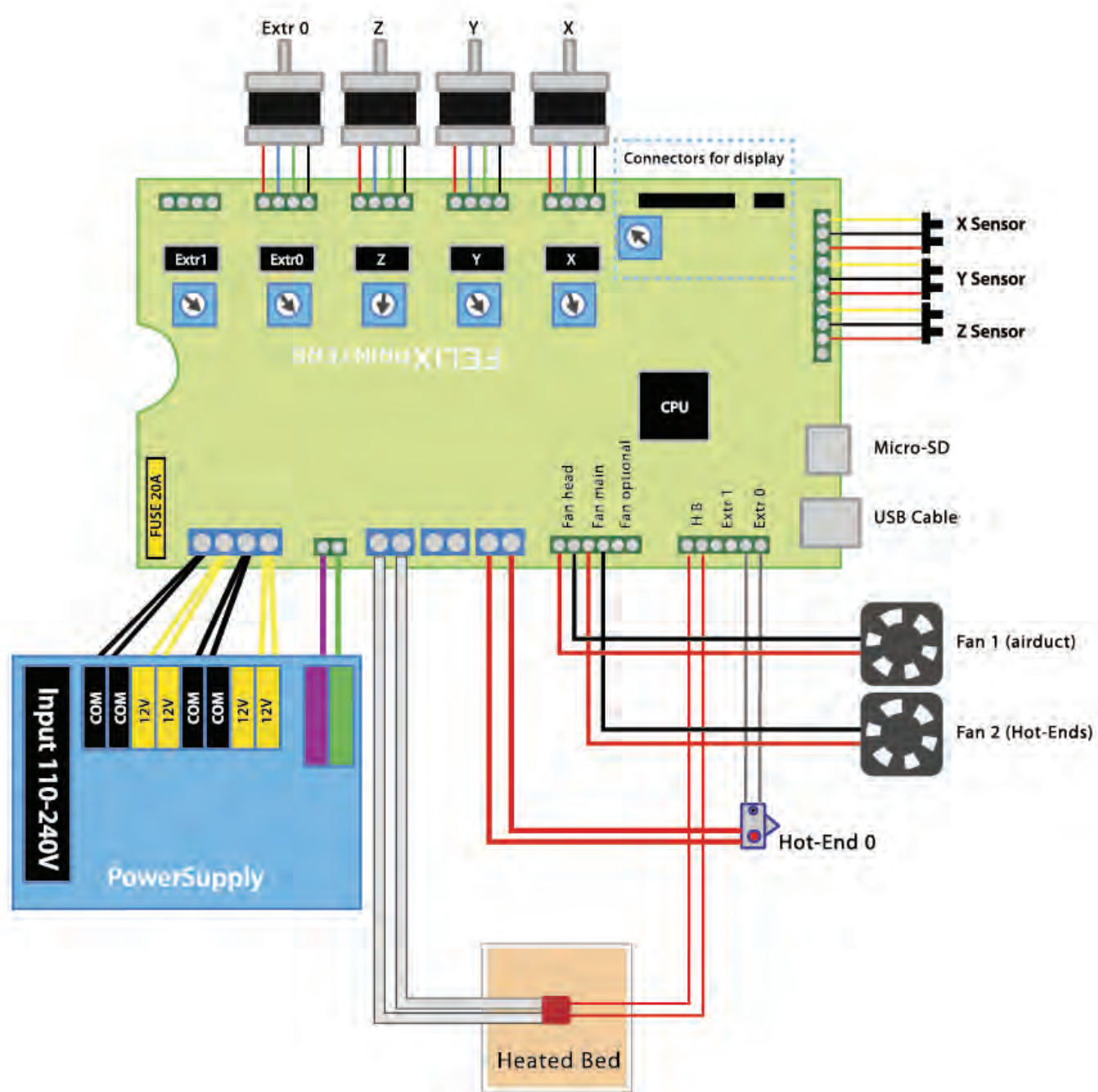



Wiring diagram for the dual extruder.

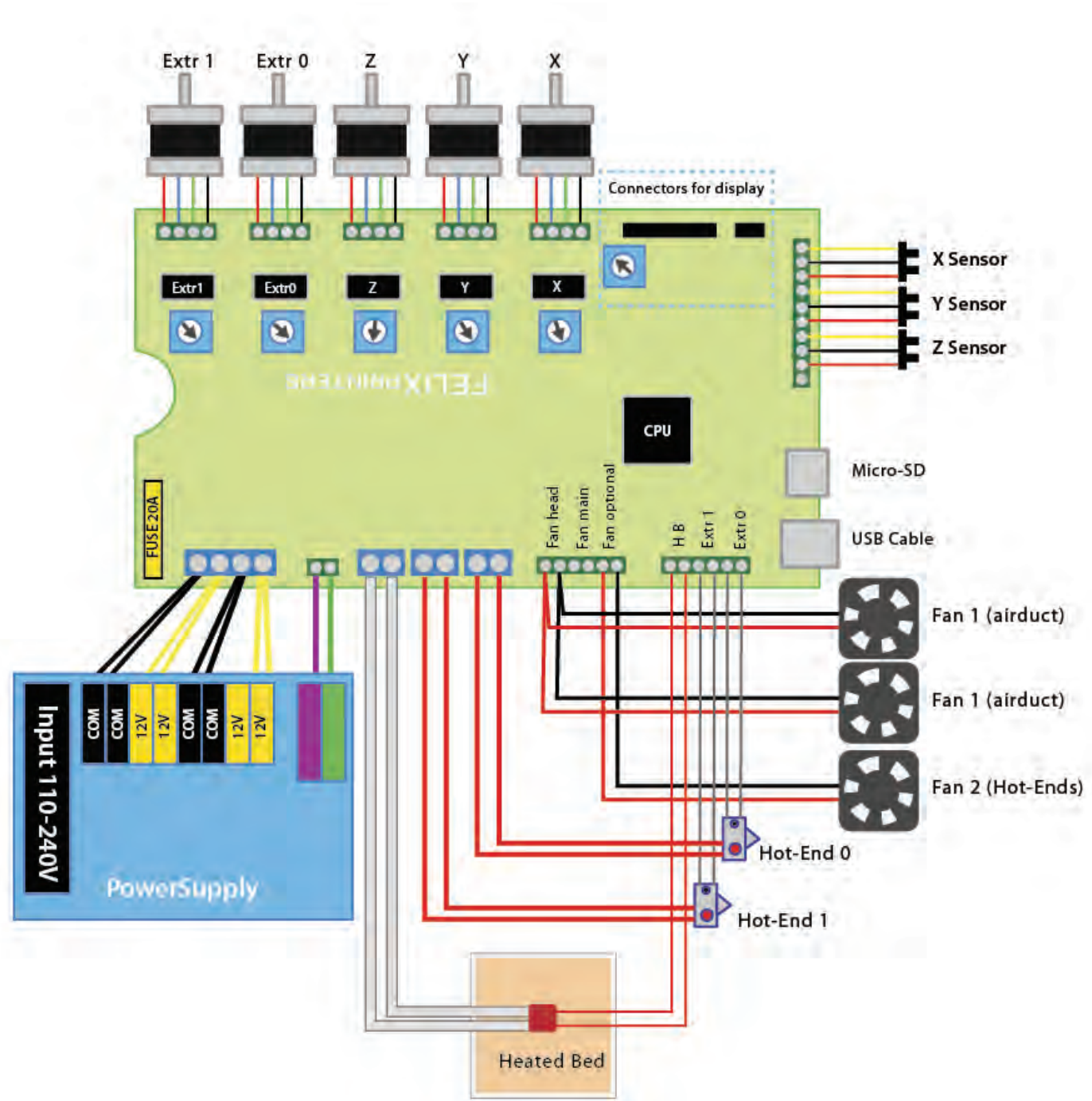

104

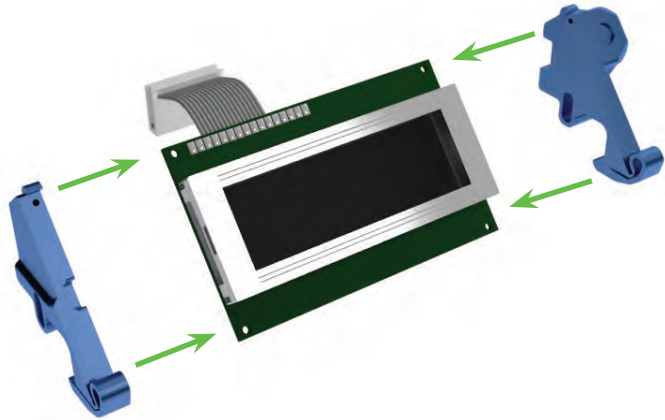

105

2x Small screw 2,2 x 8

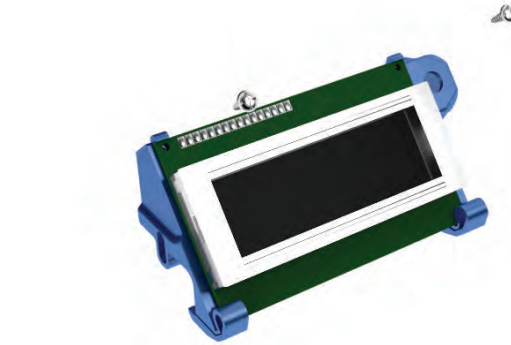
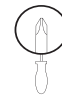

106

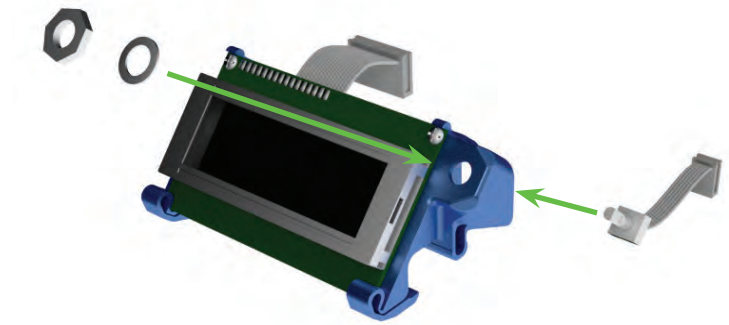

107

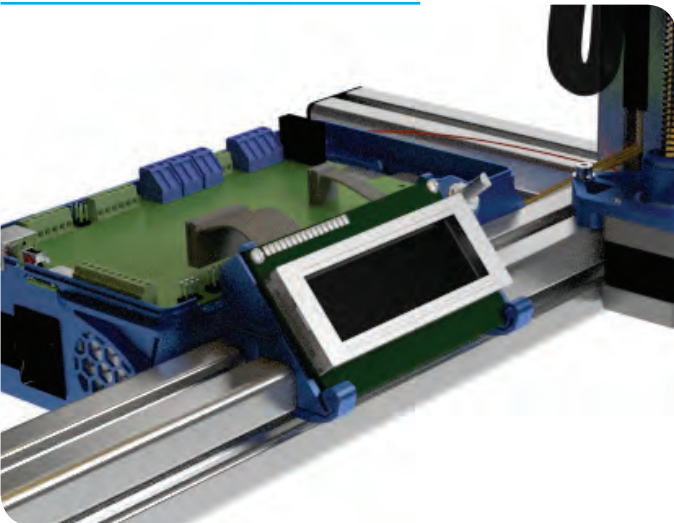

108

1x Plastic Display-cover

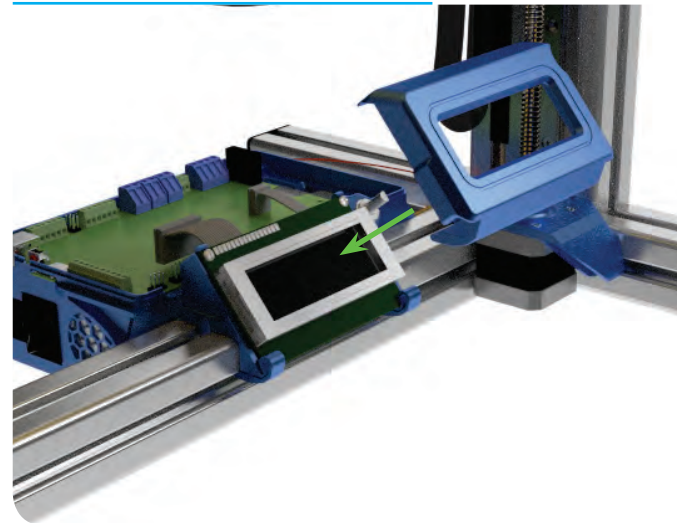

109

1x Plastic knob

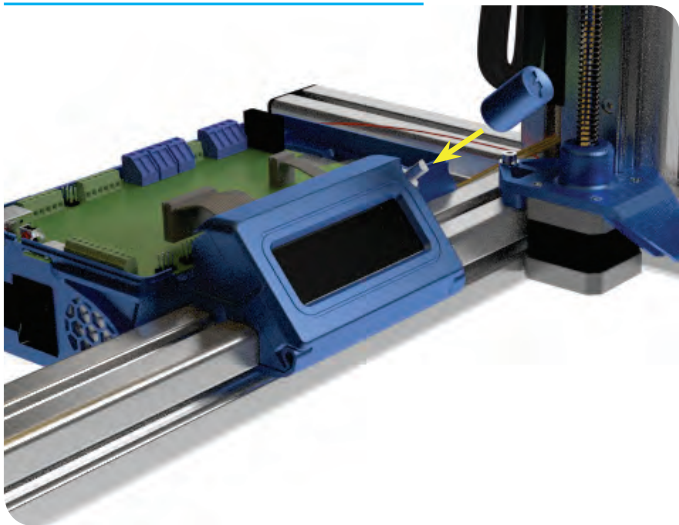

110

2x Small screw 2,2 x 8

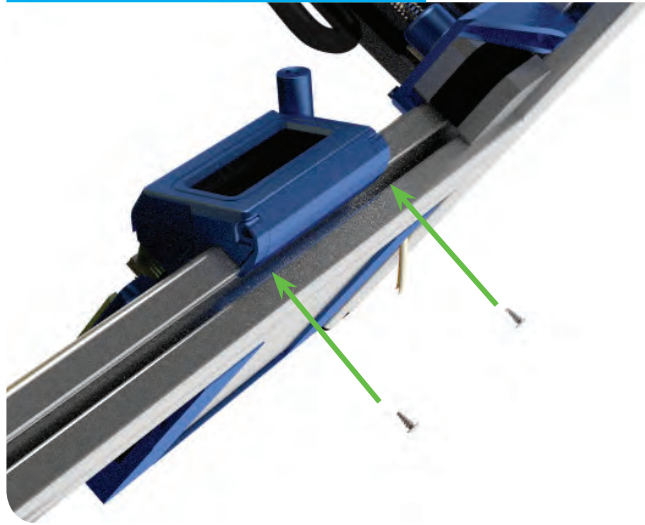

111

Connecting the display cables

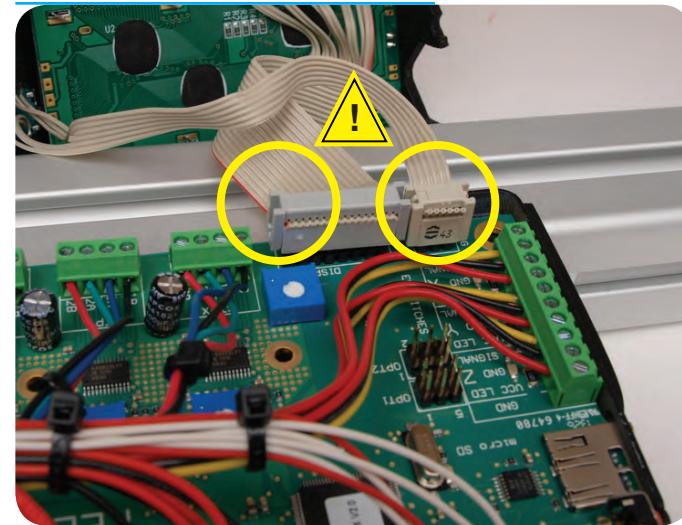

112

Attach the cover

1x Electronics enclosure cover

4x Bolt M4x12



Align the square nuts from step 88 properly before mounting the cover with the m4x12 bolts.





Peel off a corner

NOTE: It is best to place the kapton sticker when the bed is around 40-50°C. This can be done with the computer interface or the display unit. Read the user manual to learn how to do this.

Clean the print-bed surface with detergent, and try to minimize dust particles onto the surface to prevent bubbles.

Peel off a corner of the large kapton sticker and fold the corner back.

Place the kapton sticker onto the aluminum printbed. Make sure the corners align.

Slowly peel the backing of the sticker and rub the sticker diagonally onto the printbed surface. To prevent/minimize bubbles, you can use a credit card.

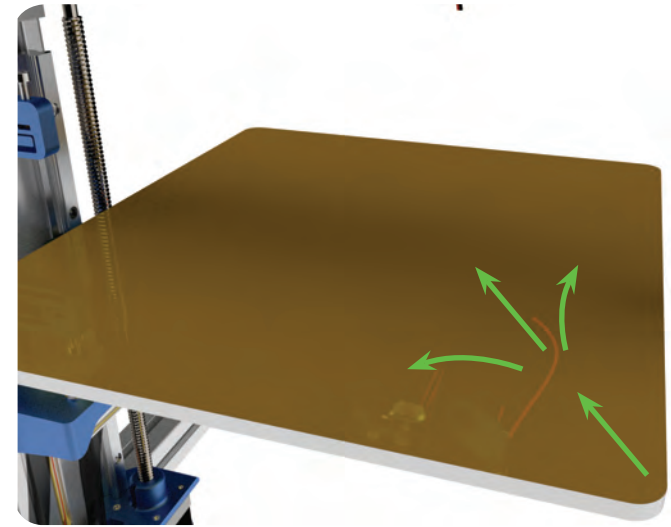













Congratulations you are finished with the assembly of the 3D printer.







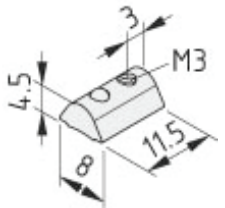
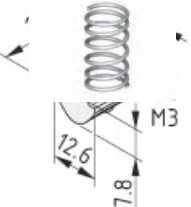

The filament holders and guide will be printed to complete the 3D printer and will test your 3D printer.

Please continue with the user manual to learn how to print in 3D.





BOM (Bill of Materials)



Prod. Nr.	Description		Image
105 018.0	Bolts & Nuts set FELIX 3.0b		
140 036.0	Set screw D-916 – M3 x 4	6	
140 011.1	Set screw D-916 – M3 x 6-N -45H	4	
140 037.0	Set screw D-916 – M4 x 30	4	
140 041.0	Hexagon socket head cap screw M3 x 35	1	
140 012.0	Bolt D-7991 - M3 x 6 --- 6N - CSK	5	
140 013.0	Bolt D-7991 - M3 x 8 --- 8N - CSK	15	
140 015.0	Hexagon socket head cap screw DIN 912 - M3 x 8	2	
140 016.0	Hexagon socket head cap screw DIN 912 - M3 x 12	3	
140 017.0	Hexagon socket head cap screw DIN 912 - M3 x 16	18	
140 038.0	Hexagon socket head cap screw DIN 912 - M3 x 30	4	
140 018.0	Hexagon socket head cap screw DIN 912 – M4 x 12	12	
140 019.0	Hexagon socket head cap screw DIN 912 – M4 x 16	4	
140 020.0	Hexagon socket head cap screw DIN 912 – M4 x 20	15	

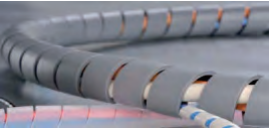





140 021.0	Hexagon socket head cap screw DIN 912 – M4 x 25	6	
140 022.0	Hexagon socket head cap screw DIN 912 – M4 x 40	4	
140 023.0	Hexagon socket head cap screw DIN 912 – M5 x 16	5	
140 024.0	WasherD- 125A M3	10	
140 025.0	WasherD- 125A M4	22	
140 026.0	WasherD- 125A M4	5	
140 028.0	Corrosserie ring - M4 - large washer	7	
140 029.0	Prevailing torque type hexagon nut DIN-985 - M3	6	
140 030.0	Prevailing torque type hexagon nut DIN 985 0 M4	8	
140 031.0	Hexagon Thin Nut D-439B – M4	35	
140 040.0	Thin square nut DIN 562 – Steel – M4	6	
140 032.0	Powersupply screw UNC 6/32 x ¼ Pozi steel	5	
140 033.1	Penhead screw D-7981-f 2,2 x 8 Phillips	8	

110 020.0	t_slot nut – 5 ST M3	2	
110 21.0	t_slot nut – 8 ST M3	3	
140 039.0	Spring (heated_bed and extruder)	5	
122 010.0	Set plastic parts Felix 3.0 (molded)		
122 011.0	X_stage_F3_0_motor_bracket_v1	1	
122 012.0	X_stage_F3_0_belt_mount_v1	1	
122 013.0	Y_stage_F3_0_Bracket pt1_v1	1	
122 014.0	Y_stage_F3_0_Bracket pt2_v1	1	
122 015.0	Y_stage_F3_0_tensioning_bracket_v1	2	
122 016.0	z_axis_F3_0_lift_part_v1	1	
122 017.0	z_axis_F3_0_motor_bracket_v1	1	
122 018.0	z_axis_F3_0_limitswitch_vane_v1	1	



122 019.0	Extru_F3_0_base_v1	1	
122 020.0	Extru_F3_0_L_shape_bracket_v1	3	
122 021.0	Extru_F3_0_arm_pt1_v1	2	
122 022.0	Extru_F3_0_arm_pt2_v1	2	
122 023.0	Extru_F3_0_airduct_v1	2	
122 025.0	Electronics_enclosure_F3_0_cap_pt1	1	
122 026.0	Electronics_enclosure_F3_0_cap_pt2	1	
122 027.0	Electronics_enclosure_F3_0_cover_v1	1	
122 028.0	Electronics_enclosure_F3_0_cover_plate_v1	1	
150 014.1	Electronics 1, F3_0b		
150 014.0	Thermistor incl 2m	1	
150 011.0	Electronics board - Felixprinters	1	
150 025.0	Fan 40x40x10 with 1.5m wires, Sunon	2	
150 023.0	Opto sensor_v2	3	

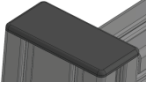
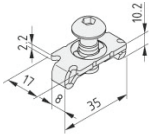

170 013.0	cable ties, set of 100	1	
170 014.0	cable spiral 1.25m	1	
170 021.0	Cable ties for mounting cables on z bracket	2	
170 022.0	cable tie stickers on extruder motor	4	
105 015.0	Electronics 2 (motors)		
150 026.0	motor nema 17	4	

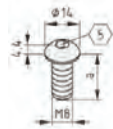
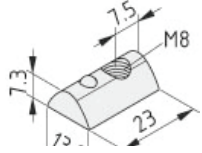
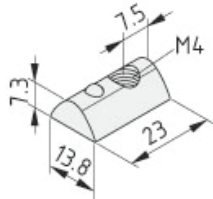



105 013.1	Mechanics, F3_0b		
130 013.0	pulley_motor_HTD	2	
130 014.0	Toothbelt HTD 3M 1.2m	1	
130 015.0	Bearing 624 5x12x6	6	



105 011.0	Frame (A)		
110 012.0	40x40x400 profile incl 2xM8	1	
110 013.0	40x40x400 profile, incl 1xM8, 1xD7	2	
110 014.0	40x40x400 profile, incl 3xD7	1	
110 011.0	80x40x440 incl work	1	
105 012.0	Frame (B)		
110 015.0	40x40 protective caps	4	
110 016.0	80x40 protective caps	1	
110 017.0	frame connector set	6	
110 018.0	handle	1	
110 019.0	Protective cap, handle	1	



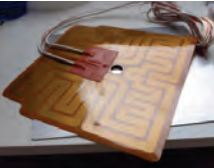
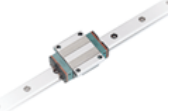
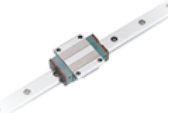

140 035.0	hex sockethead bolt M8x16 buttonhead	2	
110 024.0	t-slot nut - 8 ST M8	2	
110 022.0	t-slot nut - 8 ST M4	15	
110 025.0	dampning feet	6	





100 101.4	Axlesembled Hot-end, containing:	1	
130 019.4	Hot_End_baxlee_1_75mm_F2_0_V4	1	
130 021.4	Hot_End_peek_isolation_1_75__F2_0_v4	1	
130023.3	Hot_End_Heated_barrel_1_75_F2_0_v3	1	

130 024.1	Hot_End_tip_1_75_F2_0_v1	1	
150 013.0	Heater Cartidge incl 2m wires	1	
150 014.0	Thermistor incl 2m	1	

	Parts packed separately in DIY kit		
150 024.0	Powersupply - 1U- Enhanced electronics, with switch	1	
130.025.0	table_6mm_F3_0_v5	1	
130 017.0	Trapezium spindle TR10x2mm 330mm	1	
130 017.0	Trapezium hexagon nut TR10x2	1	
150 016.0	Kapton - Foil Heater	1	
130 011.0	Hiwin lineair ball bearing set – MGN12H1R0300Z1HM	2	
130 012.0	Hiwin lineair ball bearing set – HGW15CC1R300Z0	1	
110 026.0	strip for putting away cable pieces of 40 cm	3	

105 016.0	Miscellaneous		
150 018.0	USB cable 1.8m	1	
170 011.0	tweezers	1	
170 012.0	Kapton Sheet	1	
170 016.0	Piece of filament to start 5m	1	
170 019.0	Piece of teflon tube 40cm	1	
170 023.0	Filament dust cleaner	2	

	Optional parts depending on region		
150 019.0	Power Cable EU	1	
150 020.0	Power Cable USA	1	
150 021.0	Power Cable AU	1	
150 022.0	Power Cable UK	1	

100 074.0	Upgrade kit single to dual head F3.1b		
170 019.0	piece of teflon tube 40cm	1	
110 026.0	strip for putting away cable pieces of 40 cm	1	
100 101.4	Hot-end v4, axlesembled	1	
150 025.0	Fan 40x40x10 with 1.5m wires, Sunon	1	
150 027.0	Stepper motor nema 17, short motor, 1.5m wires, flat shaft	1	
130 015.0	small bearing	1	
170 023.0	Filament dust cleaner	1	
130 016.1	extruder_insert_part_v3.1	1	
140 029.0	Prevailing torque type hexagon nut DIN-985 - M3	1	
140.041.0	Hexagon socket head cap screw M3 x 35	1	
130 026.0	Dual_Extruder_Clamp	1	
130 027.0	Dual_Extruder_Mover	1	