



Assembly Manual FELIX 3.2

www.felixprinters.com
support@felixprinters.com

Zeemanlaan 15
3401 MV IJsselstein
The Netherlands

16 December 2021
Revision 02

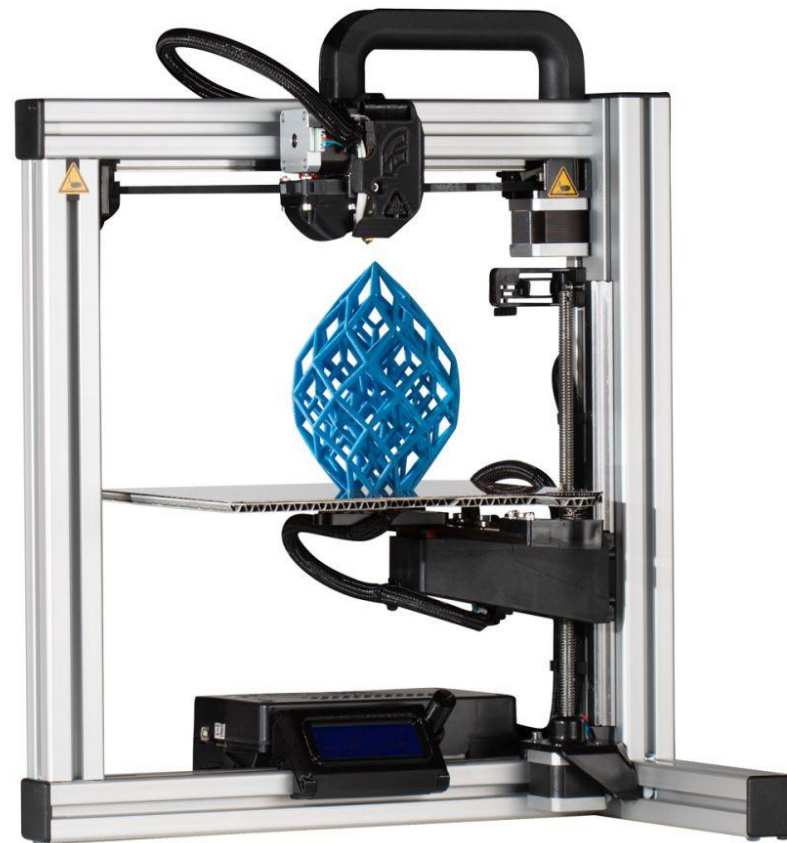

1 Introduction

Dear Customer,

Thank you for choosing FELIXprinters!

To get your Felix 3D printer up and running as fast and painlessly as possible please follow this manual carefully. Please don't take any shortcuts. It's better to spend a few minutes extra on reading, than to wait a week for new parts.

When things are unclear or if you have any remarks or tips, please contact us:

Website: www.felixprinters.com/support
 Email: support@felixprinters.com
 Telephone: +31 (0)30 30 31 387
 Address: Zeemanlaan 15, 3401MV IJsselstein, The Netherlands

We also recommend looking on our forum and getting yourself a forum account. You will benefit from the ability to get downloadable and printable upgrades for your printer. Also it is a great source to obtain and share knowledge about your 3D printer and 3D printing in general.

Have fun building!

Kind regards,

FELIXprinters

2 Contents

1	Introduction.....	1
3	Required Tools	2
4	Frame assembly	3
5	Z-axis	5
6	X-axis	8
7	Y-axis	12
8	Extruder assembly	16
8.1	For Single head assembly	16
9	Extruder assembly	19
9.1	For Dual head assembly	19
10	Wiring.....	22
11	Upload Firmware	27
12	Functional Test	28
13	Finishing Touches	30
14	Checklist	32
15	Bill Of Materials.....	34
15.1	FELIX 3.2 DIY Kit - Base parts - 105 014.1	34
15.2	FELIX 3.2 Single to Dual Upgrade Kit - 105 031.0	38
15.3	Set Plastic parts Felix 3.2 - 105 047.1	39

Required Tools

3 Required Tools



Allen key
1.5, 2, 2.5, 3, 4 and 5



Wrench 5.5, 7 and 12



Cutter



Tweezer



Screwdriver flat head



Screw driver Philips head



Knife



Rubber hammer



Ruler



Detergent



Grease/Lubricant

4 Frame assembly

30 minutes

Tools:

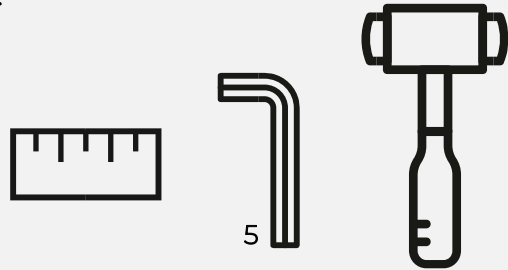

1

- (1x) Profile 4
- (2x) Bolt M8 x 20
- (2x) Frame Connector

Tools

2

- (1x) Profile 1

3

4

- (1x) Profile 4
- (1x) Bolt M8 x 20
- (1x) Frame Connector

5

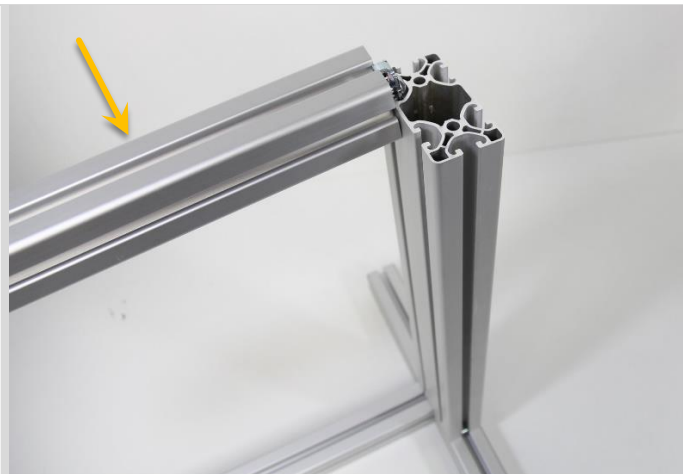
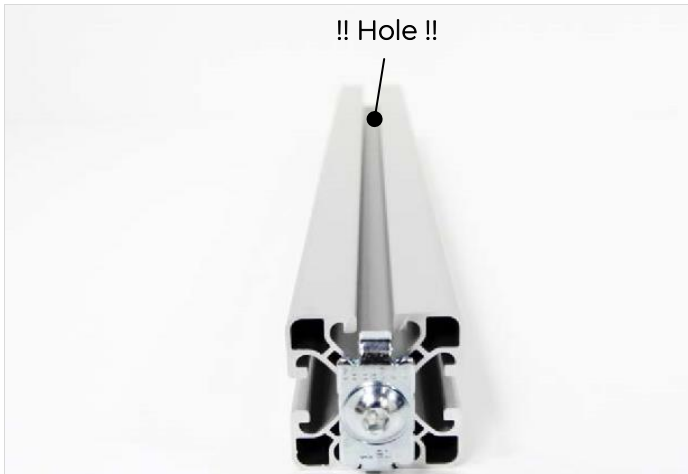

6 (1x) Profile 2
(1x) Bolt M8 x 20
(1x) Frame Connector

Tools

7

8 (1x) Profile 3
(2x) Bolt M8 x 20
(2x) Frame Connector



9

10 Make sure the profiles are properly aligned. If not untighten the screws and re-adjust the profiles

11 (4x) End Cap Square
(1x) End Cap Rectangle

5 Z-axis

45 minutes

Tools:



12 Example – Insert T-Nut:
Insert the nut into the slot

Tools



13 Example – Insert T-Nut:
Insert the key into the threaded hole and rotate the nut into position

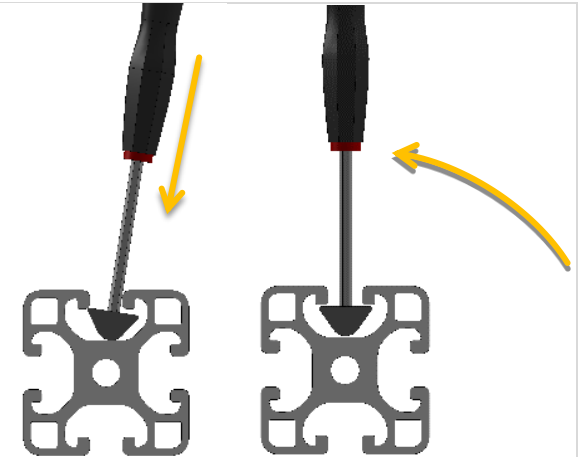

14 (4x) CSK Bolt M3 x 8
(1x) Motor
(1x) Z-Axis Motor Bracket



15 (1x) Cable Stepper Z



16 (1x) Motor Assembly
(2x) T-Nut M4
(2x) Bolt M4 x 20
(2x) Small Washer M4

Tools:



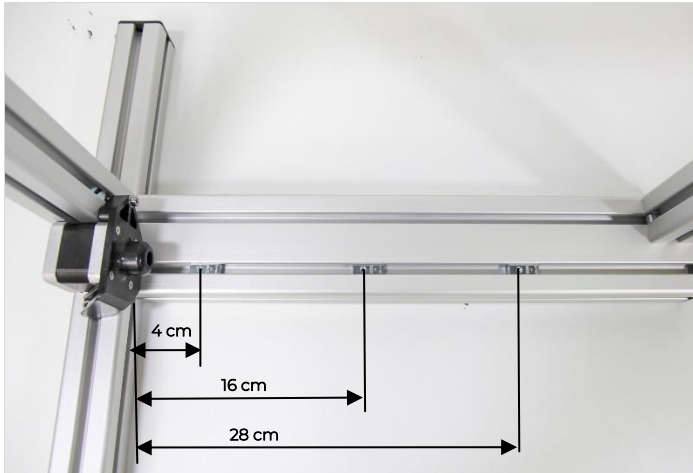

17 (3x) T-Nut M4
Tools: 2

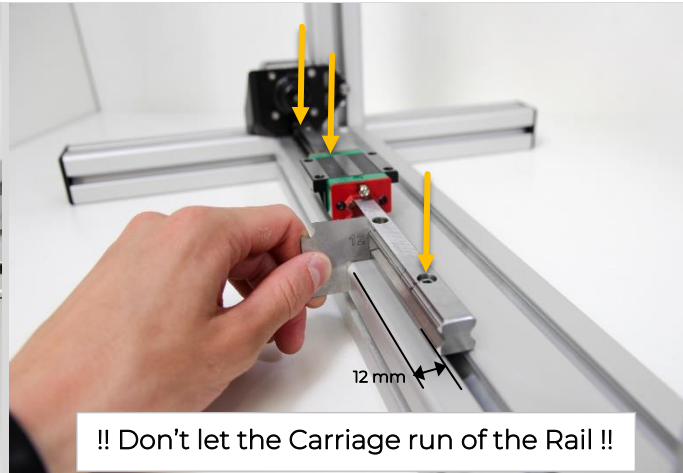

18 (3x) M4 x 20
(1x) Linear Guide HGW15
Tools: 3
!! Don't let the Carriage run of the Rail !!



19 (1x) Z-axis lift
(1x) Hexagon Nut

!! Remove Bolts after pulling Locknuts into Z-Axis Lift !!

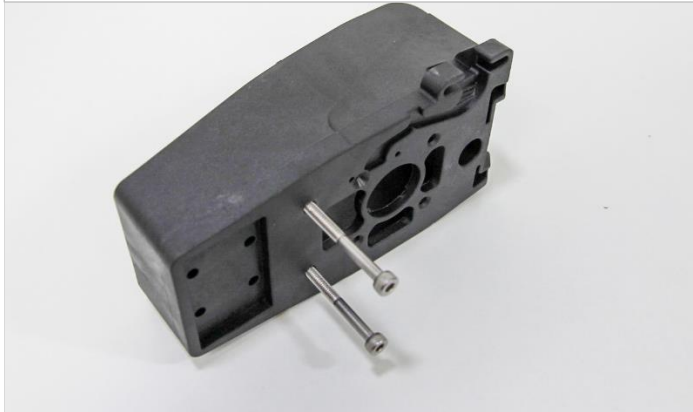

20 (2x) Bolt M4 x 40
(2x) Locknut M4

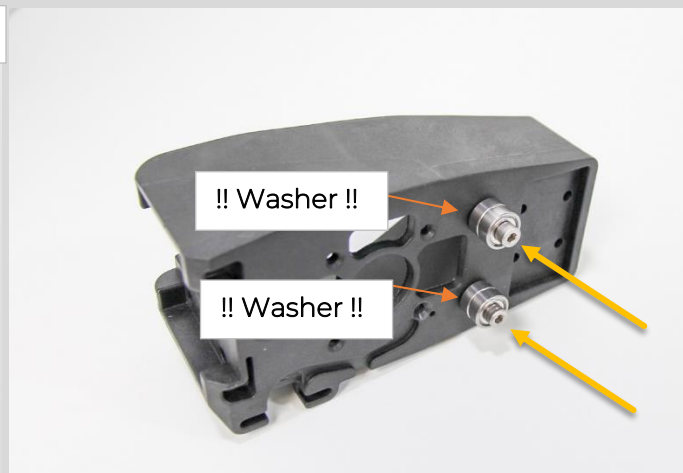

21 (4x) Bearing
(2x) Bolt M4 x 25
(2x) Small Washer M4

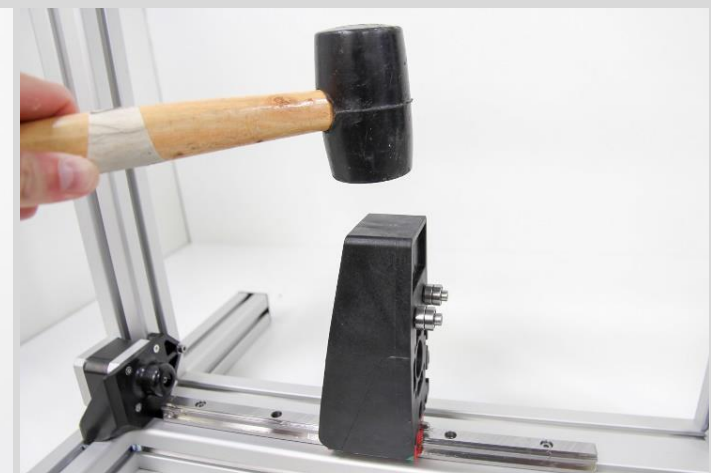

22

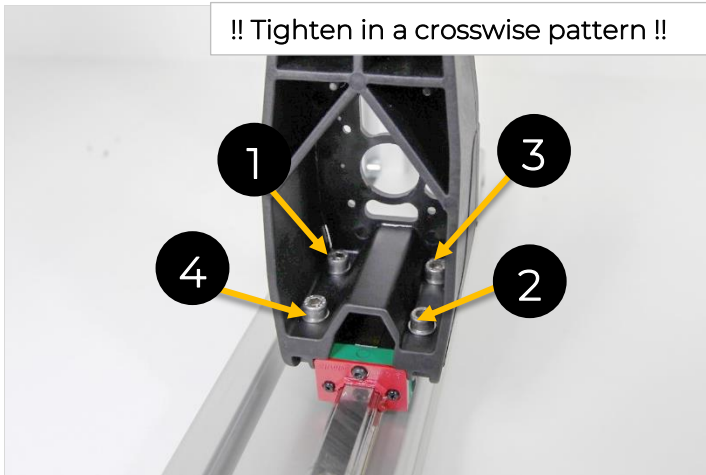

23 (1x) Z-Axis Lift Assembly
(4x) Bolt M5 x 16
(4x) Small Washer M5

Tools:  4

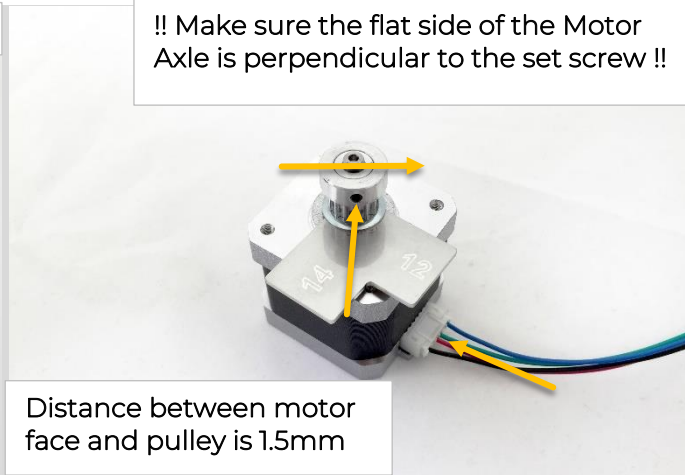

24 (1x) Motor
(1x) Pulley
(1x) Set Screw M3 x 6
(1x) Cable Stepper Y

Tools:  1.5

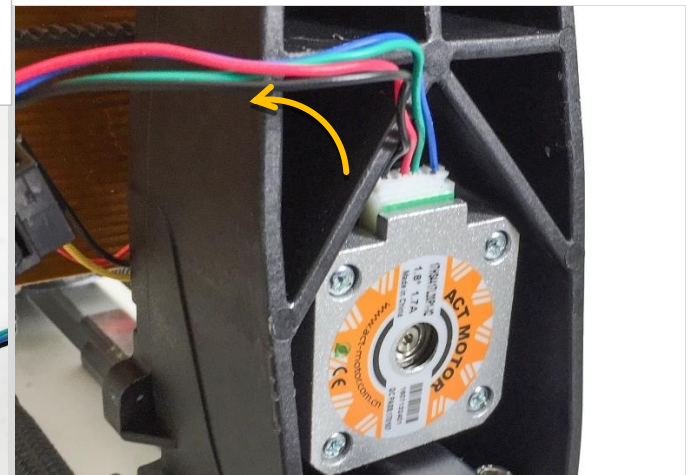

25 (1x) Cable Stepper Y

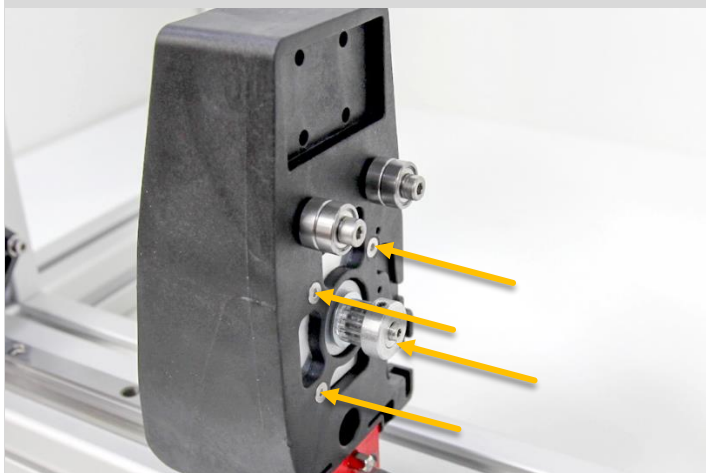

26 (1x) Motor
(4x) CSK Bolt M3 x 8

Tools:  2

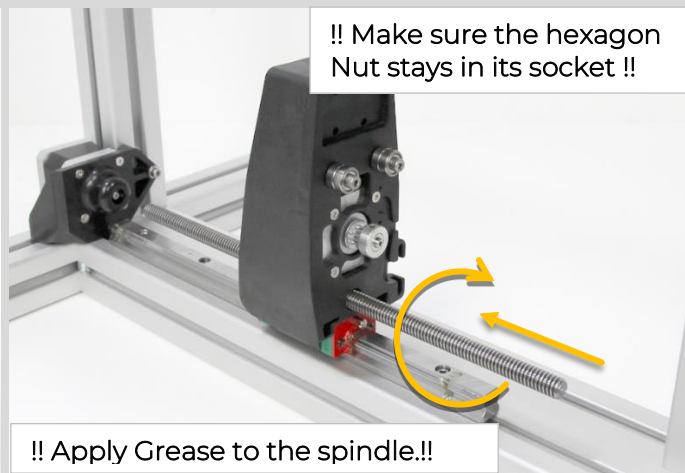

27 (1x) Spindle

Tools: 

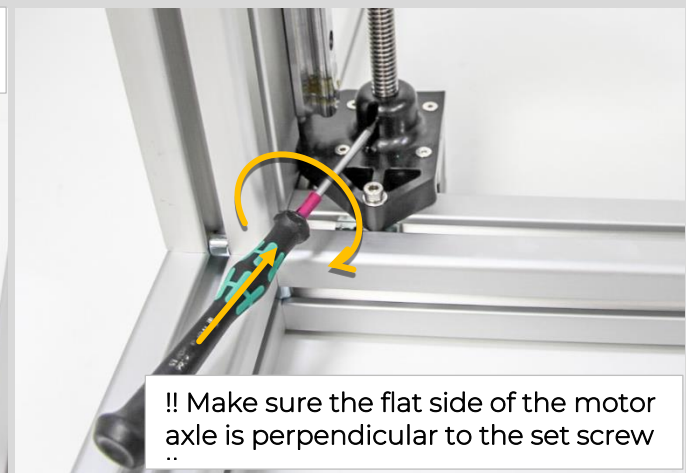

28 (1x) Set screw M3 x 6

Note: use a high quality and sharp 1.5mm allen key to properly fix the spindle of the motor

Tools:  1.5

6 X-axis

60 minutes

Tools:

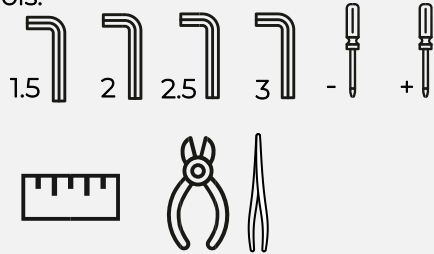

29 (1x) T-Nut M4

Tools



30

(2x) Bearing
(1x) Small Washer M4
(1x) X-axis Belt mount
(1x) Bolt M4 x 40

Tools

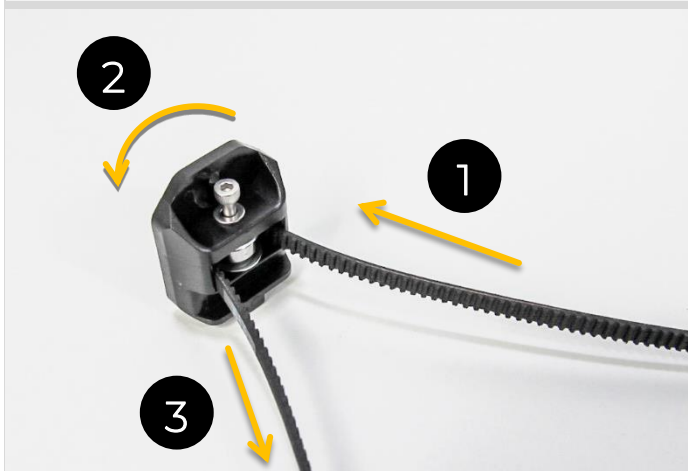
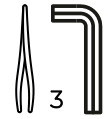

31 (1x) Belt



32 (1x) X-axis belt mount assembly

Tools

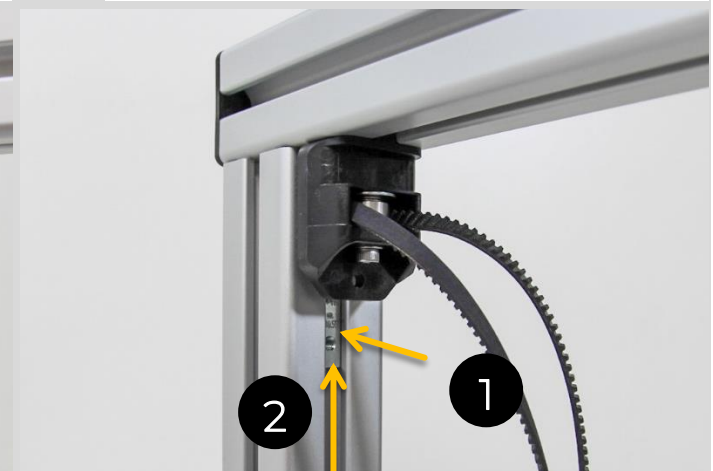

33

(1x) T-Nut M4

Tools

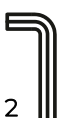



34

(1x) Bolt M4 x 16
(1x) Small Washer M4

Tools:



3



35

(1x) T-Nut M4

Tools:



2



36

(1x) Bolt M4 x 16
(1x) Small Washer M4
(1x) X-axis Motor Bracket

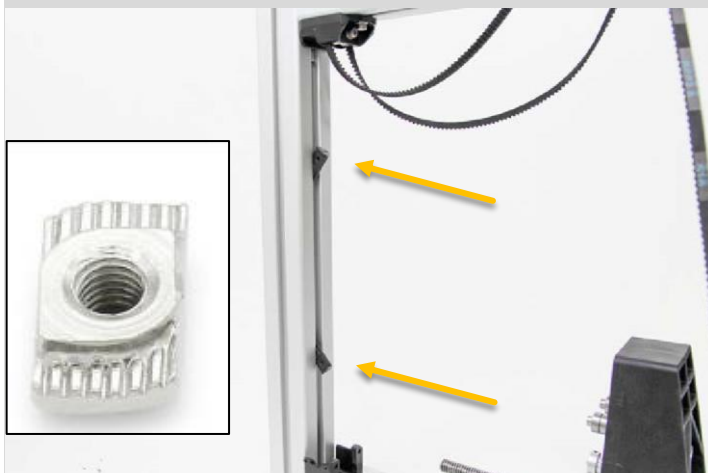

37

(2x) T-hammer nut M3

Tools:



2

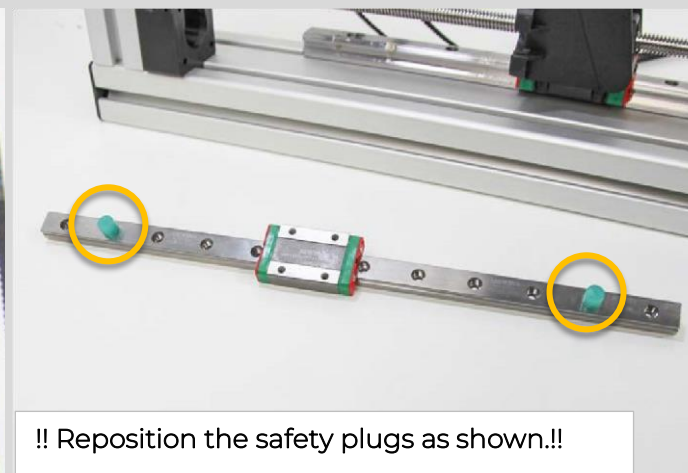

!! Reposition the safety plugs as shown!!

38

(1x) Linear Guide MGN 12



!! Distance between edge of rail and beam = 14mm!!

39

(2x) Bolt M3 x 12
(1x) Linear Guide MGN12

Tools:

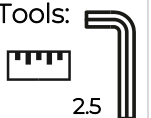

2.5

!! Make sure to position the Rail against X-axis belt mount!!



40

Tools:



2.5



Distance between motor face and pulley is 1.5mm

41

- (1x) Motor
- (1x) Pulley
- (1x) Set screw M3 x 6

Tools:

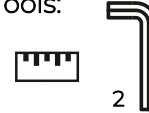

2



42

- (1x) Cable Stepper X



43

- (1x) Motor Assembly
- (4x) CSK Bolt M3 x 8

Tools:

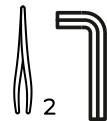

2

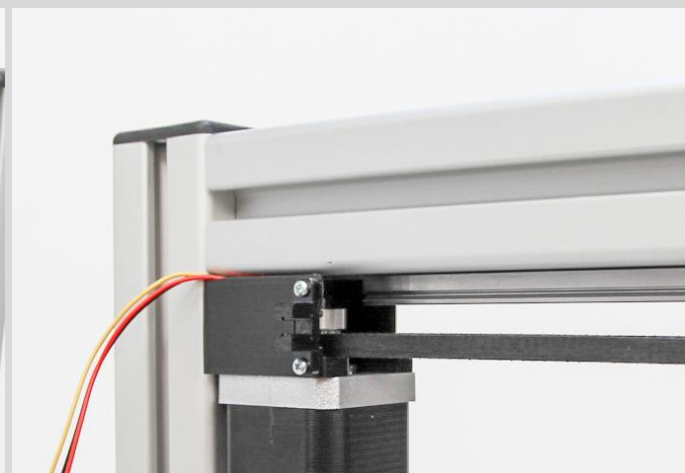

44

- (2x) Small Screw 2.2 x 8
- (1x) Opto Sensor X

Tools:



+

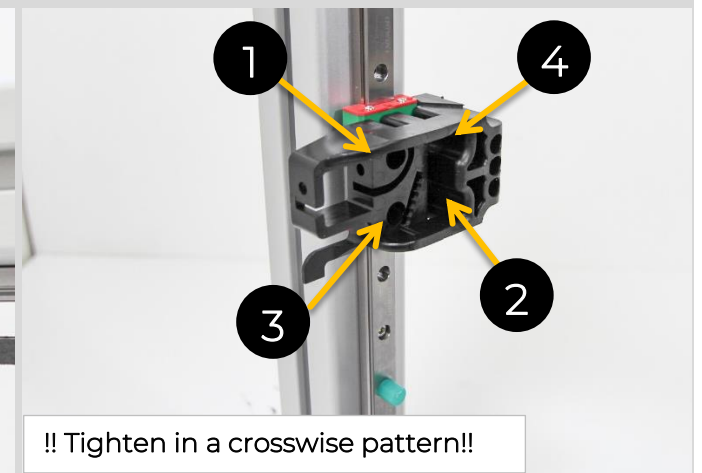

!! Tighten in a crosswise pattern!!

45

- (4x) CSK M3 x 6
- (1x) Extruder Base

Tools:



2

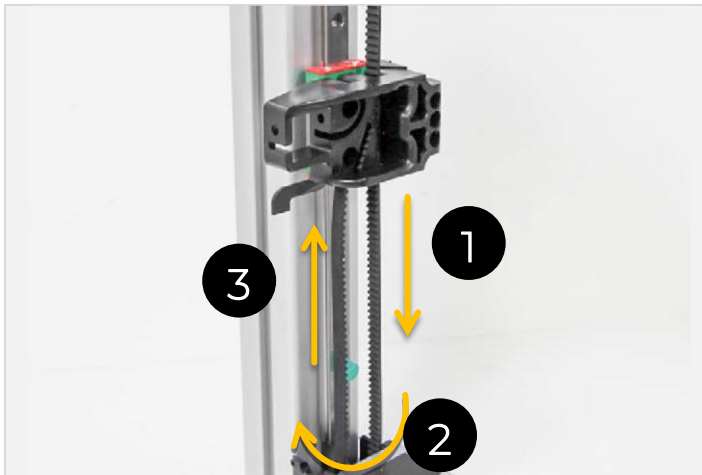

46

Tools:



2.5

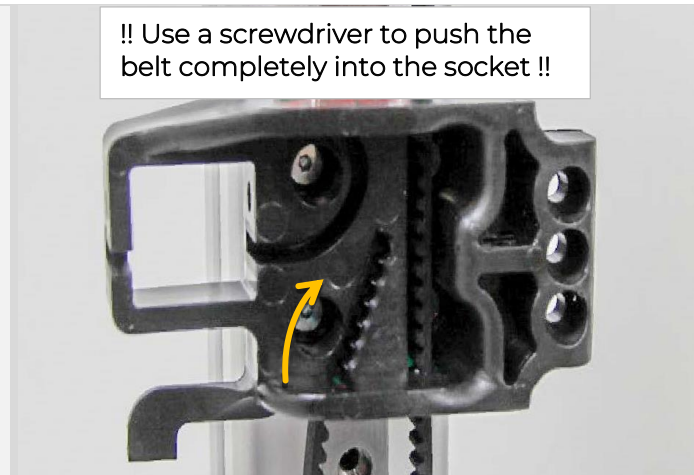

47

Tools:

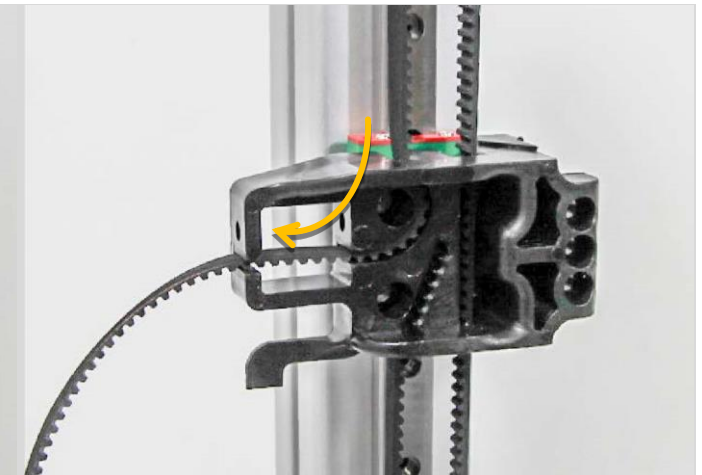

48



49

(1x) Tension bracket
(1x) Square nut M4

Tools:

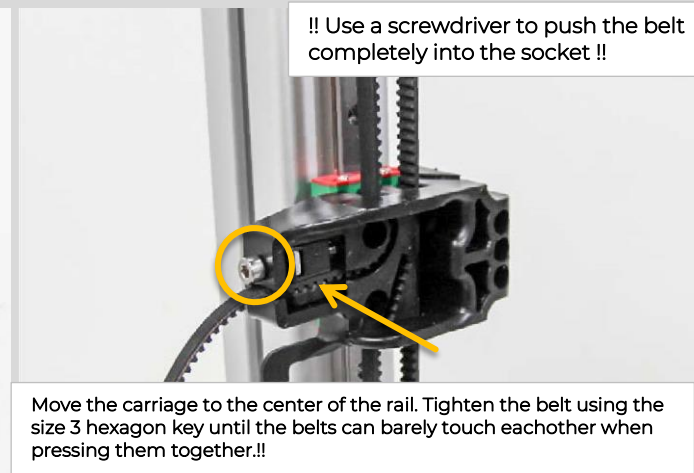

50

(1x) Tension bracket assembly
(1x) Bolt M4 x 25

Tools:

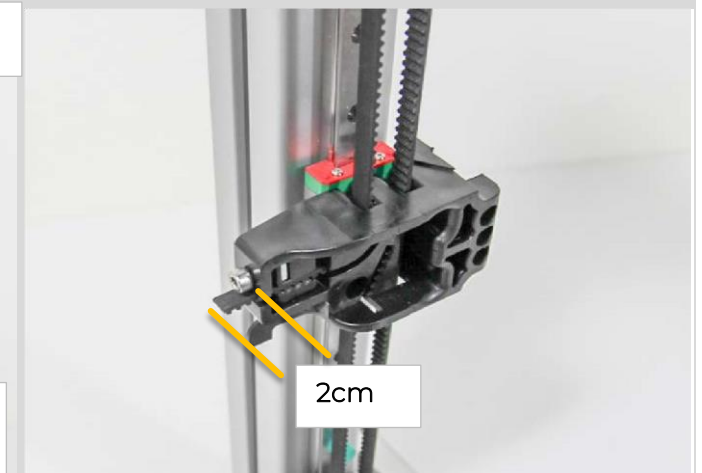

51

Tools:



7 Y-axis

30 minutes

Tools:

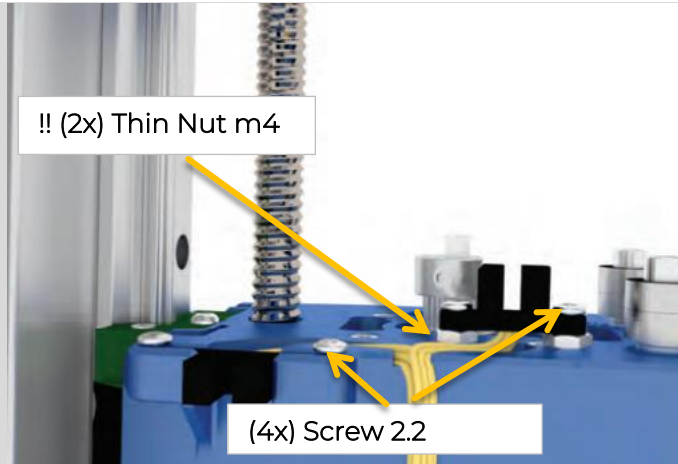
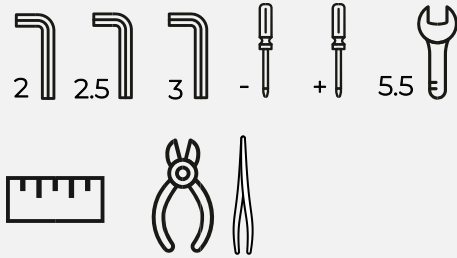

52

- (4x) Small Screw 2.2 x 8
- (2x) Thin Nut M4
- (2x) Opto Sensor Y/Z

Tools

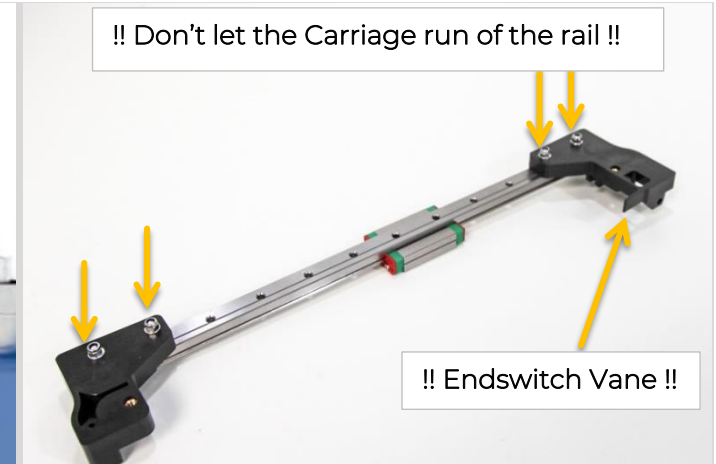

53

- (4x) Bolt M3 X 16
- (4x) Locknut M3
- (4x) Small washer M3
- (1x) Y-stage bracket Pt.1
- (1x) Y-stage bracket Pt.2
- (1x) Linear Guide MGN12

Tools

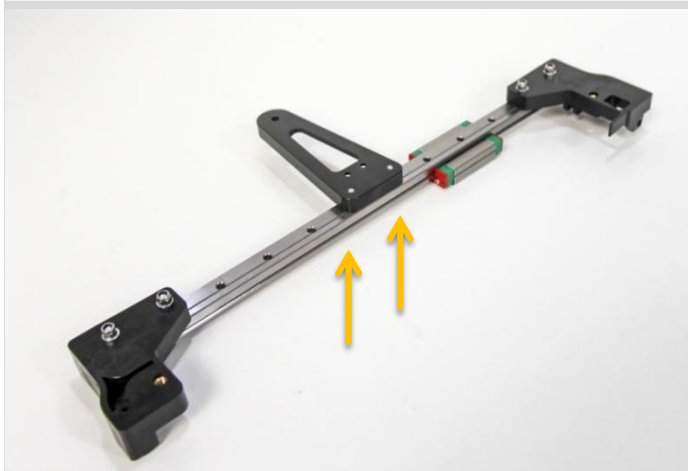
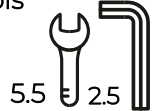

54

- (2x) Bolt M3 x 12
- (1x) Y-Stage bracket

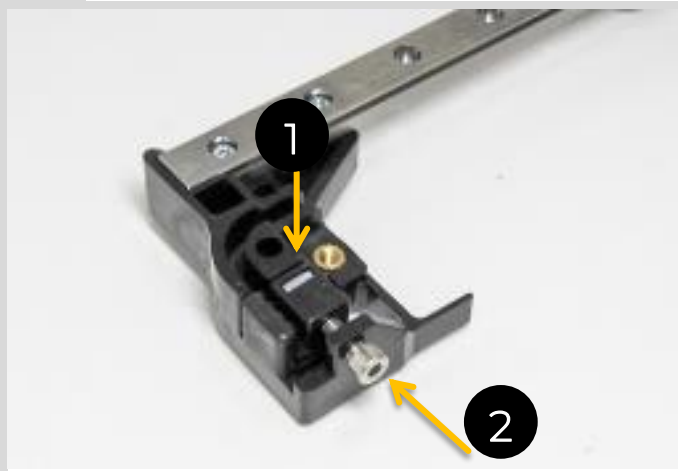

55

- (1x) Tension Bracket
- (1x) Bolt M4 x 25
- (1x) Square Nut M4

Tools

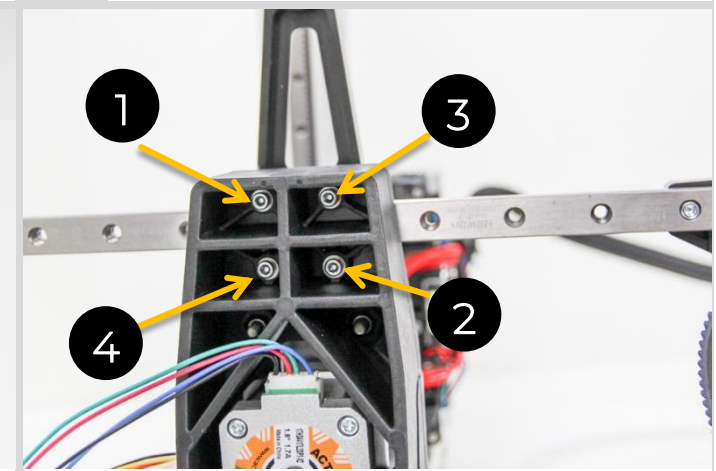

56

- (4x) Bolt M3 x 16
- (4x) Small Washer M3
- (1x) Y-stage Assembly

Tools



!! Use the screwdriver to push the belt completely into the socket !!

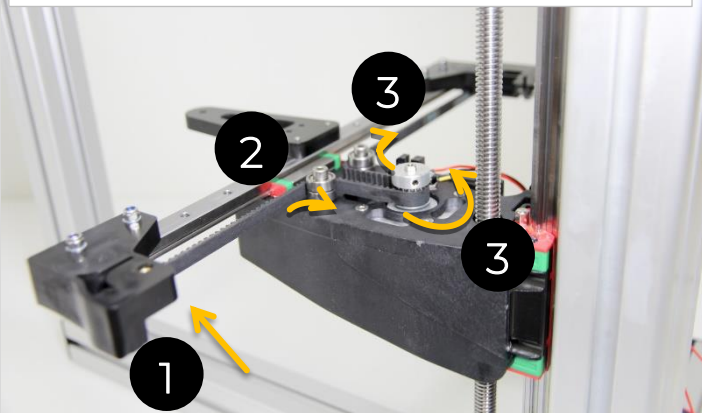

!! Use the screwdriver to push the belt completely into the socket !!



Tensioning the belt:
Move the y-axis completely to one end. Tighten the belt using the size 3 hexagon key until the belt can barely touch the rail of the y-axis.

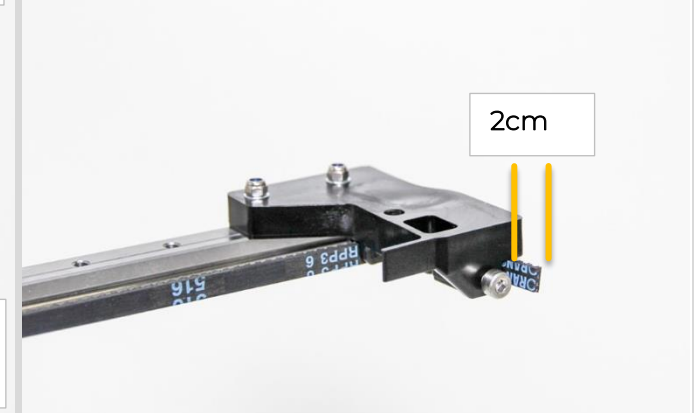

57 (1x Belt

Tools:



58

Tools:



59

Tools:



60 (1x) Build Platform
(1x) Short wire sleeve

Tools:



61 (2x) Knurled thumb screw
(2x) Set screw m4 x 30
(2x) Thin nut M4

Tools:





62 Fix the set screw into the thumb screw. Put m4 thin nut onto the set screw.

Tools:





63 Lock the set screw by fixing the nut onto the thumb screw. While fixing the nut keep set screw in place with allen key.

Tools:  



64 (2x) Thumb screw
(2x) Spring
(1x) Build platform assembly

Tools: 



65 (2x) Cable tie

Tools: 



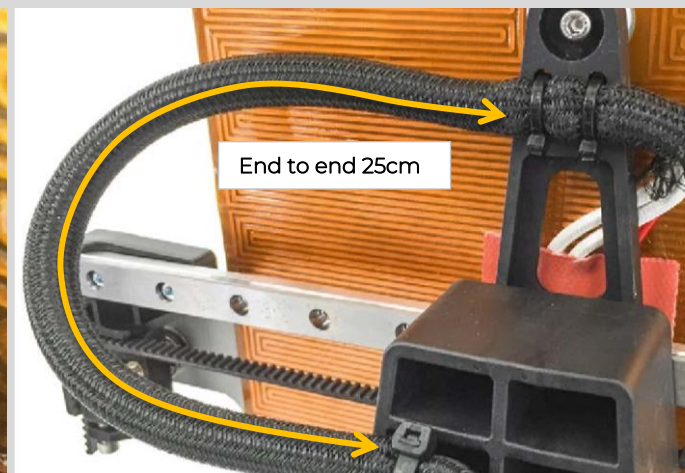

66 (1x) Bolt M4 x 12
(1x) Spring

Tools: 



67 (1x) Cable ties for mounting cables on z bracket.

Tools:  

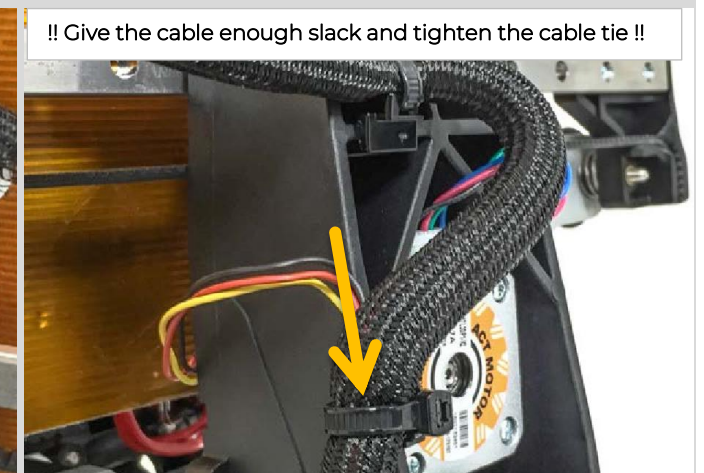

68 (1x) Cable ties for mounting cables on z-bracket.

Tools: 

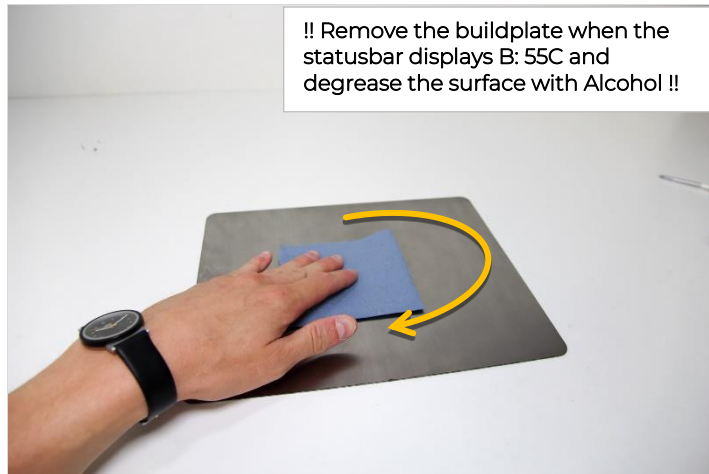

69 (1x) Flexible buildplate
Clean thoroughly to remove any grease of the plate

Tools:

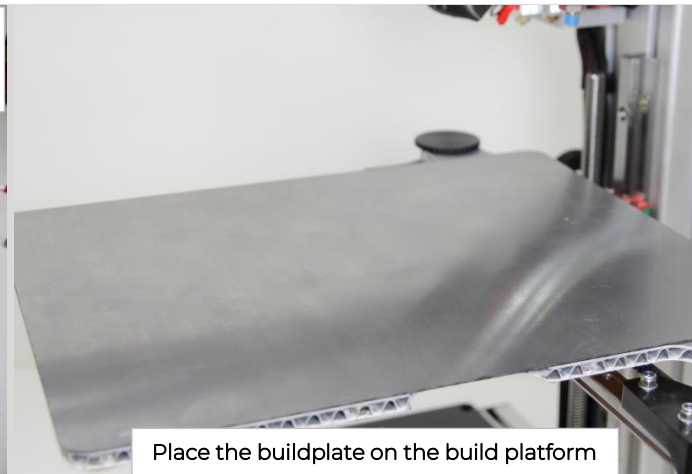
70 (1x) Flexible build plate

8 Extruder assembly

8.1 For Single head assembly

Incase you have a dual head printer -> GOTO next chapter

60 minutes

Tools:

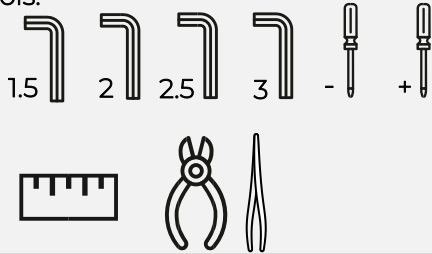

71 (1x) Bolt M4x12
(2x) Large washer M4
(1x) Spring
(1x) Thin nut M4

Tools: 3

72 (1x) Extruder arm pt1
(1x) Extruder arm pt2
(1x) Bearing

Tools

73 (1x) Extruder wheel
(1x) Set-screw M3x4
!Make sure the flat side of the axle is perpendicular to the

Tools: 1.5 2

74 (1x) Extruder L shaped bracket
(2x) Thin square nut M4

Tools: 7

!TIP! You can hold the square nut in place by temporary placing the M4x40 bolt

!Make sure the stepper connector is facing to correct way!

75 (1x) Extruder L shaped bracket
(3x) Bolt M3x30

Tools: 2

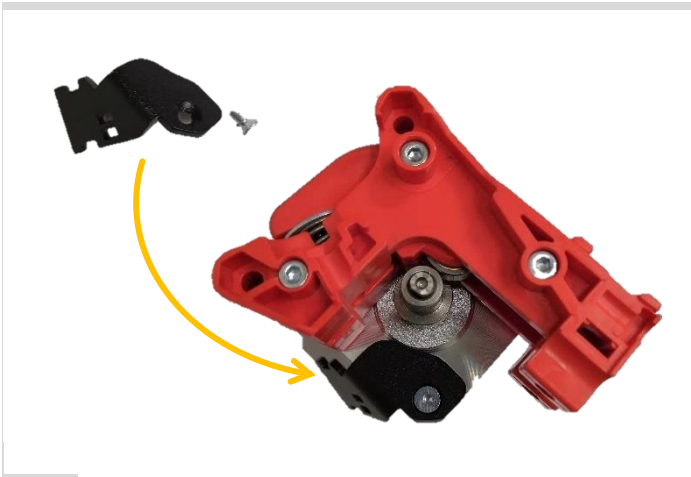

76 (1x) Cable guide bracket
(1x) Countersunk M3x6



77 (1x) Extruder hot-end clamp
(1x) Fan
!Make sure the fan wires are oriented correctly!

Tools



78 (1x) Extruder airduct
(3x) Bolt M4x20
(3x) Thin nut M4

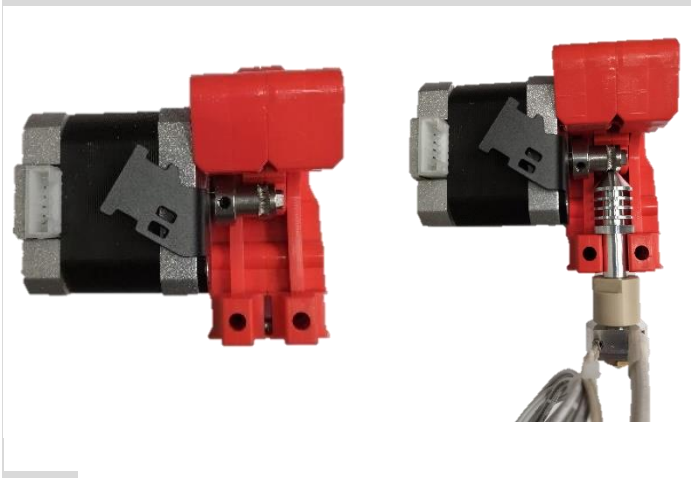
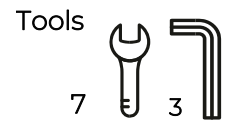

79 (1x) Hot-end assembly
!Make sure the cables are facing towards you!



80 Assemble the two sub-assemblies.

Tools

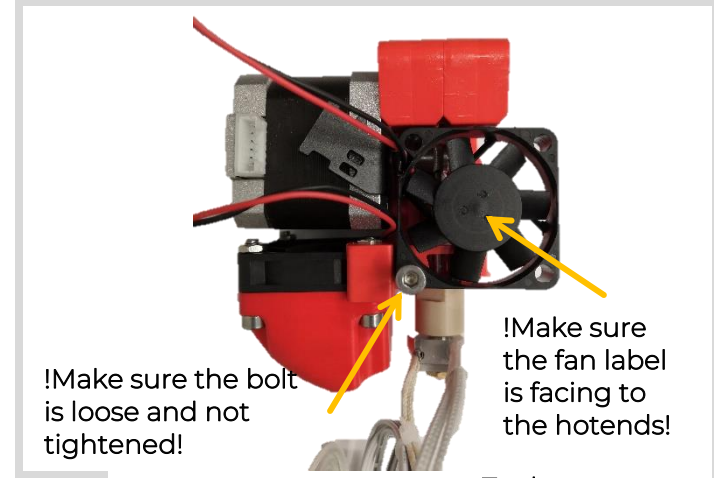

81 (1x) Bolt M4x40

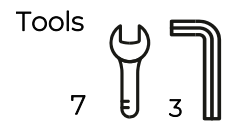

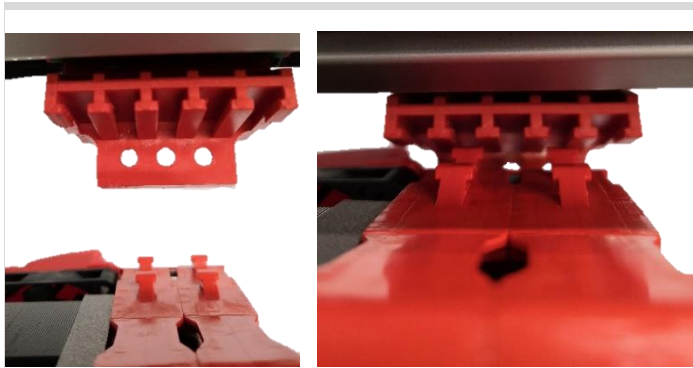

82 Slide the hotend assembly onto the carriage assembly



Bottom

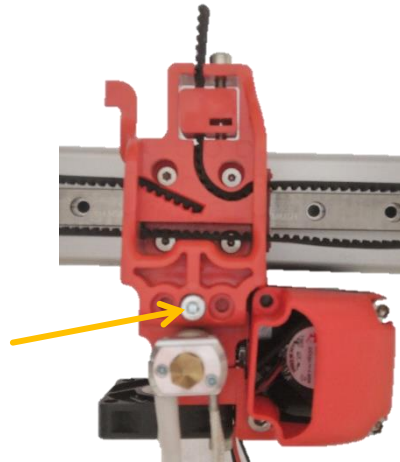

83 (1x) Bolt M4x12

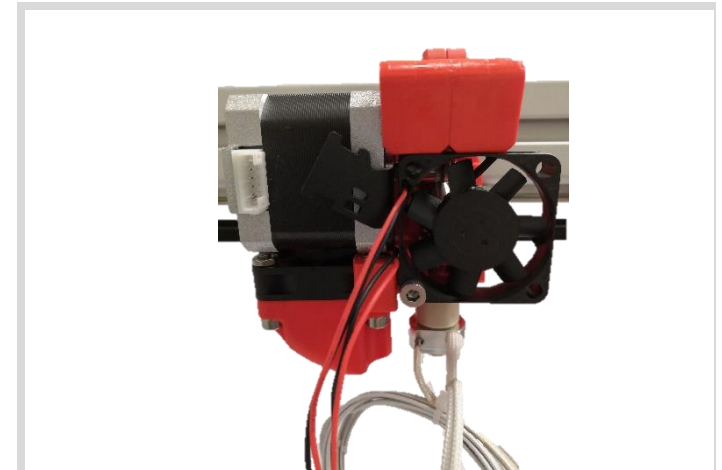
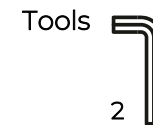

84 Tighten the fan bolt and you're done

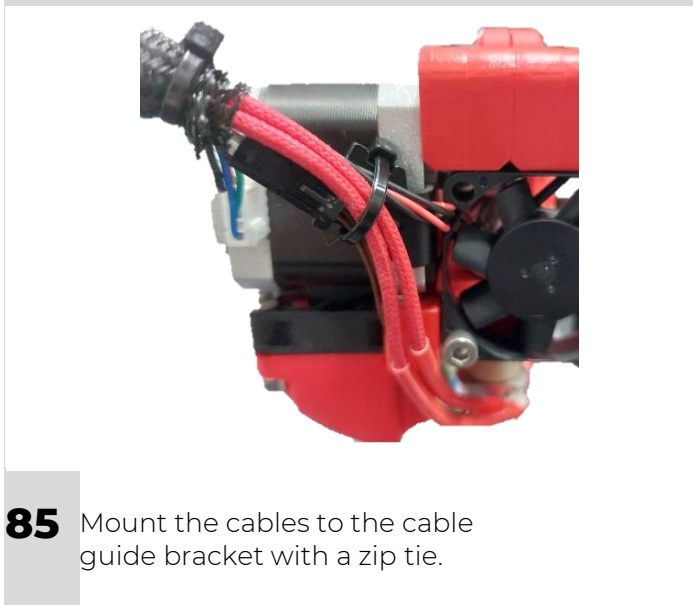
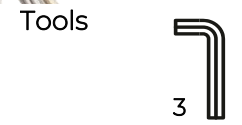

85 Mount the cables to the cable guide bracket with a zip tie.

9 Extruder assembly

9.1 For Dual head assembly

60 minutes

Tools:

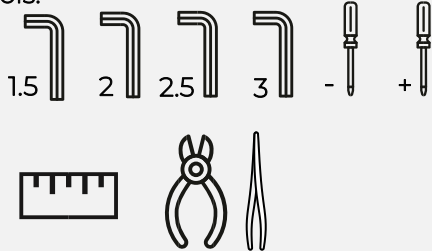

2x

86 (1x) Bolt M4x12
(2x) Large washer M4
(1x) Spring
(1x) Thin nut M4

Tools 3

2x

87 (1x) Extruder arm pt1
(1x) Extruder arm pt2
(1x) Bearing

Tools

2x

1.5 mm distance!

88 (1x) Extruder wheel
(1x) Set-screw M3x4
!Make sure the flat side of the axle is perpendicular to the

1.5 2

89 (1x) Extruder L shaped bracket
(3x) Bolt M3x16

!TIP! You can hold the square nut in place by temporary placing the M4x40 bolt

!Make sure the stepper connector is facing to correct way!

Tools 2

90 (1x) Extruder L shaped bracket
(3x) Bolt M3x16

!Make sure the stepper connector is facing to correct way!

Tools 2

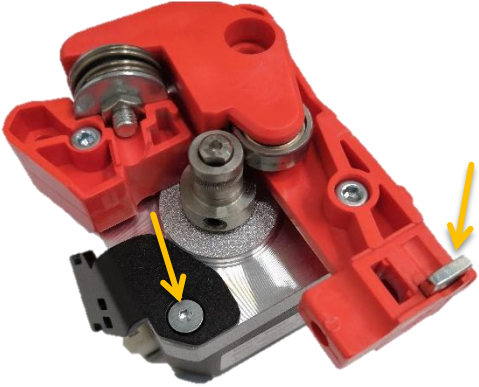

91 (1x) Cable guide bracket
(1x) Countersunk M3x6
(1x) Thin square nut M4
(1x) Extruder arm

Tools  2

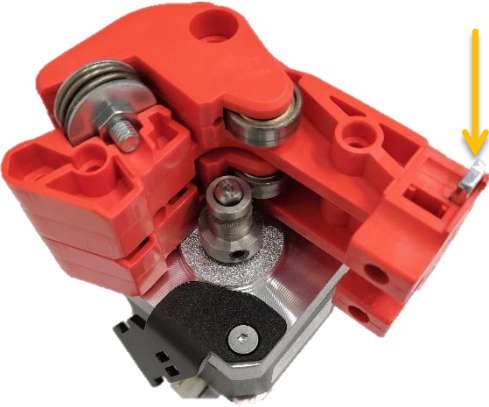

92 (1x) Thin square nut M4
(1x) Extruder L shaped bracket
(1x) Extruder arm

Tools 

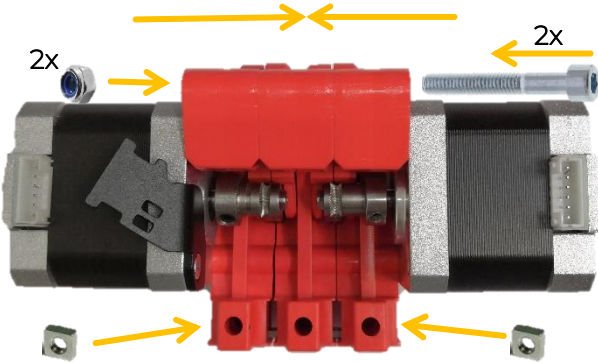

93 Mount the two sides together using:
(2x) Self-locking nut M4
(2x) Bolt M4x40
(2x) Square nut M4

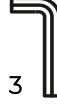
Tools  3

Back



Front



94 (1x) Self-locking nut M3
(1x) Round head M3x16
(1x) Front bracket

Tools  5.5  2

Front

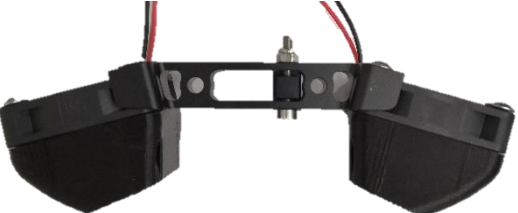

Top

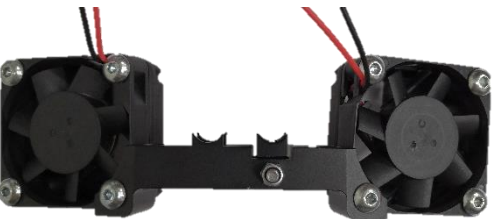

95 8x) Round head M4x16
(1x) Front bracket assembly
!Make sure the fan wires are positioned correctly!
!Make sure the fan labels are facing downwards!

Tools  3



96 Slide the hotend assembly onto the carriage assembly.

Tools 

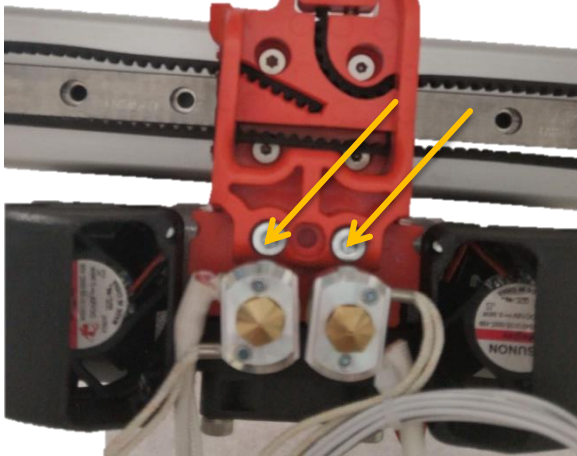

97 (2x) Bolt M4x12

Tools

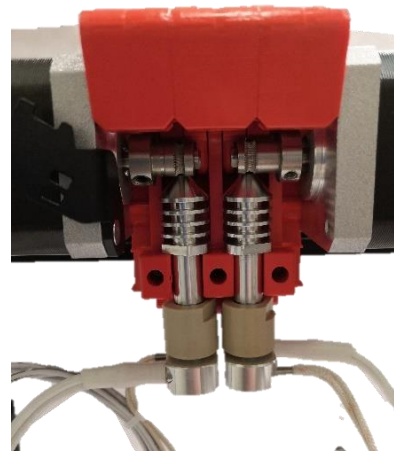

98 Mount the hotends
!Make sure the cables run to the outside!

Tools

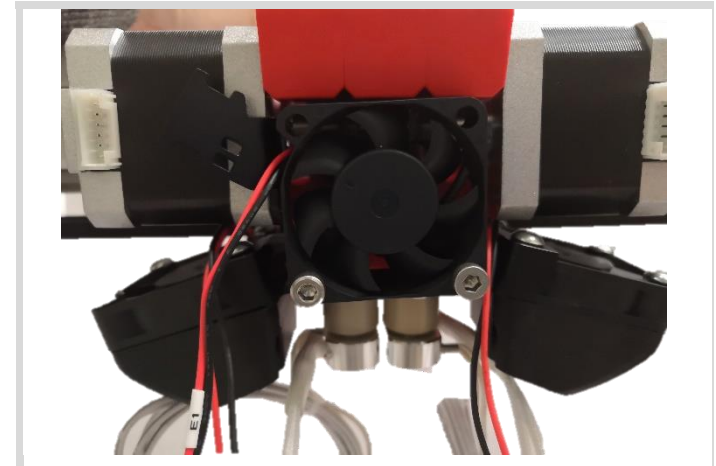

99 Mount the fan duct
assembly using:
(2x) Bolt M4x40
And you're done!

Tools

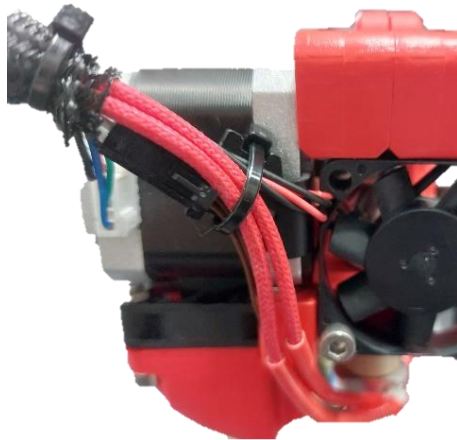

100 (Mount the cables to the cable
guide bracket with a zip tie.

Tools



10 Wiring

60 minutes

Tools:

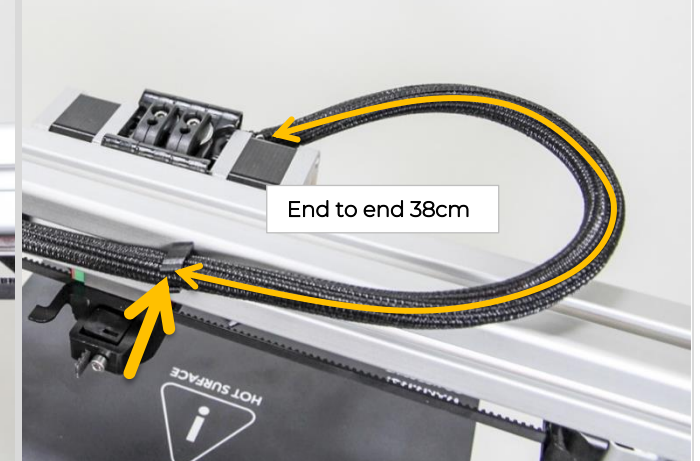
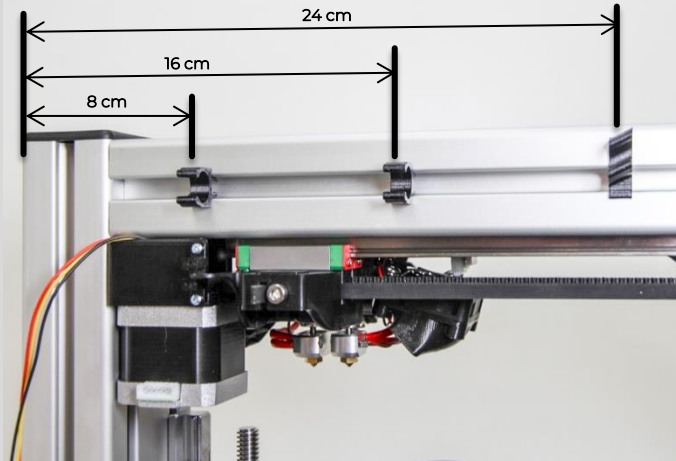

101

102

(2x) Single cable clip
(1x) Angled cable clip

Tools:



103

Tools:

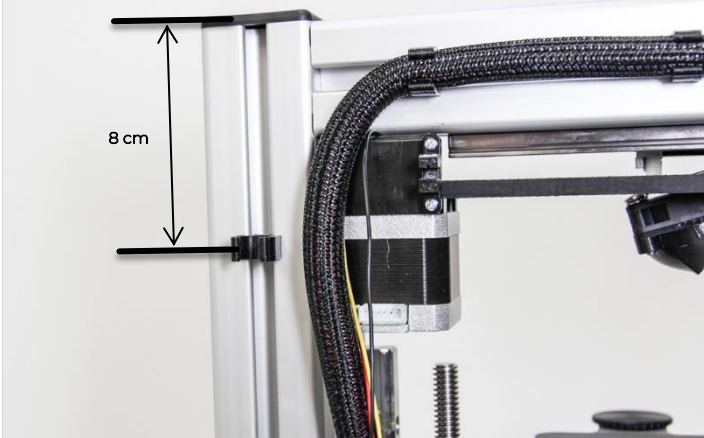

104

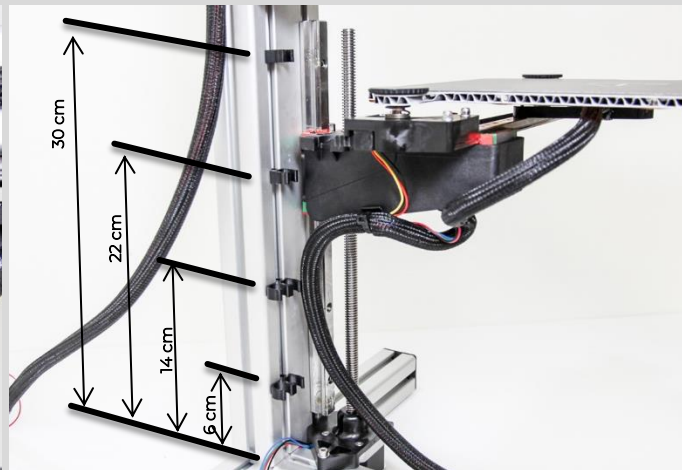

105

(2x) Single cable clip
(2x) Dual cable clip

Tools:

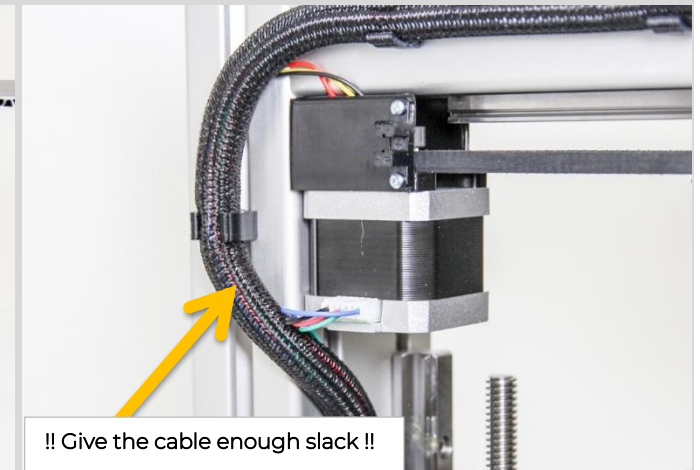

106

Tools:

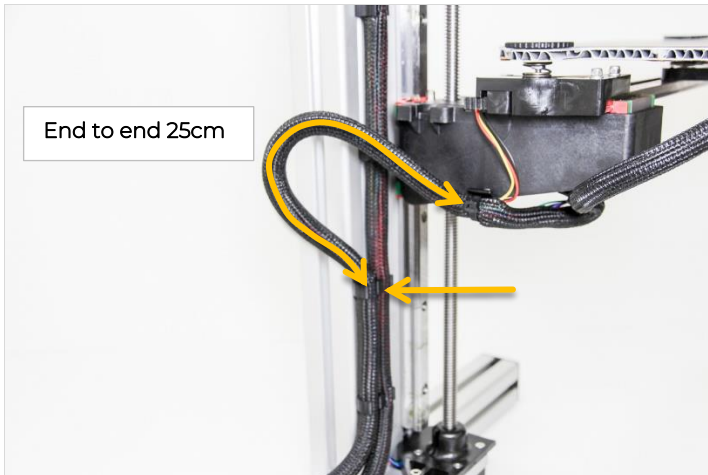

107

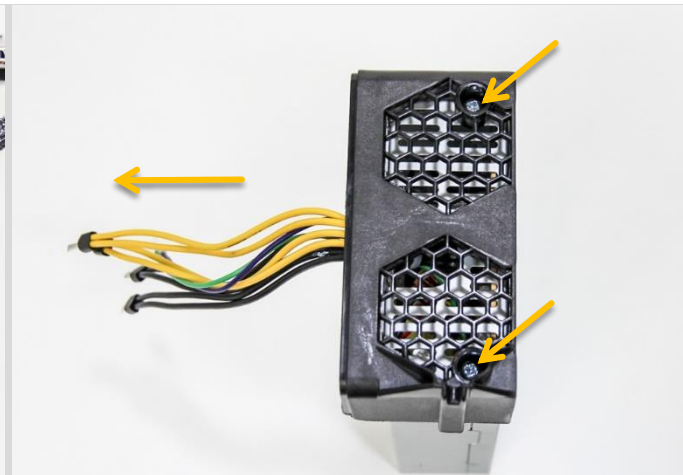

108

- (2x) Power supply screw
- (1x) Power supply
- (1x) Electronic enclosure pt 2

Tools:



109

- ((2x) Power supply screw
- (1x) Electronic enclosure pt 1

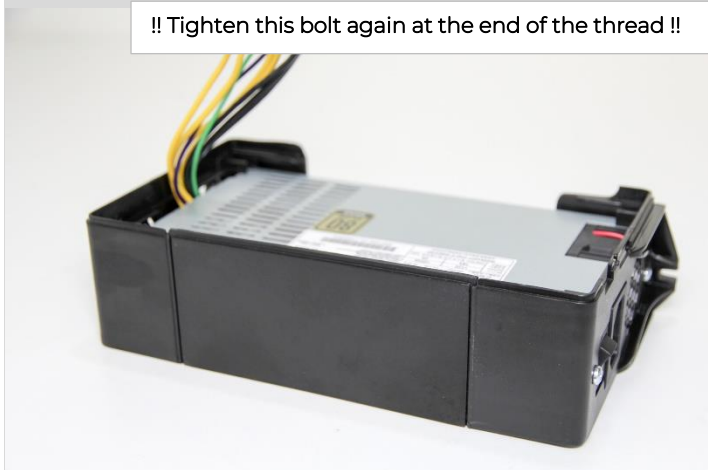

110

- (1x) Electronic enclosure
- Cover plate



111

- (2x) T-nut m4
- (2x) Bolt M4 x 12

Tools:

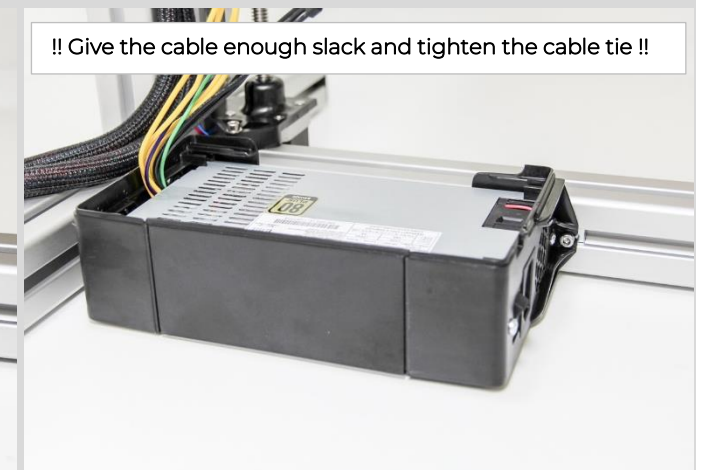

112

- (1x) Electronic enclosure assembly

Overview: Control board

Important:

1. Set the blue potentiometers of the stepper motors to the correct value as shown in the overview.
2. Turn the blue potentiometer of the display until the display contrast is normal.
3. Make sure the Control board is positioned correctly, so that the underside doesn't touch the power supply.

Note:
E0 = E1 E1 = E2 on controlboard

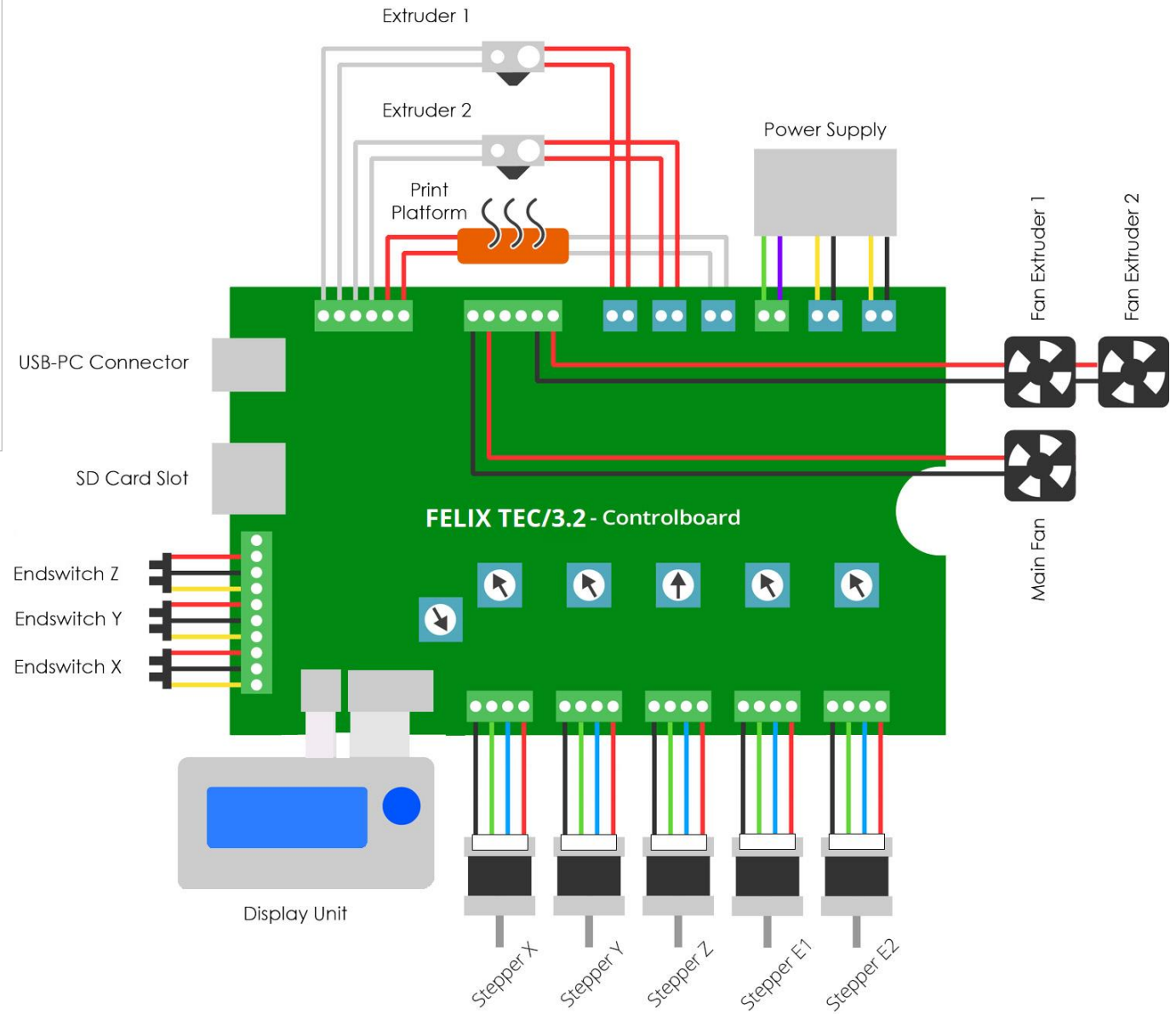

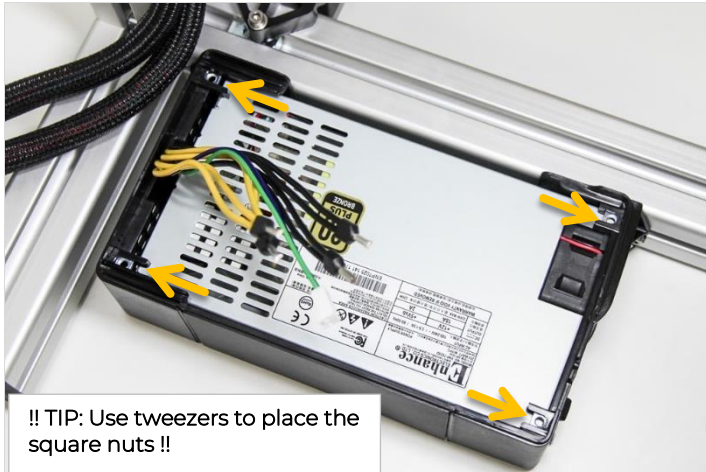

!! TIP: Use tweezers to place the square nuts !!

113 (4x) Square Nut M4



114 (1x) Control Board

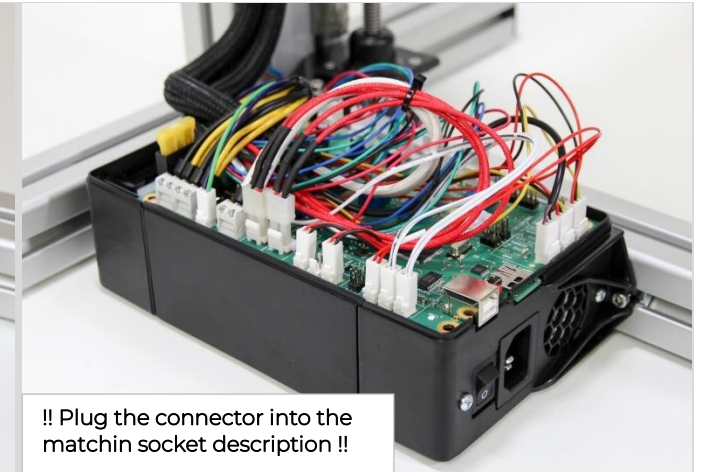

!! Plug the connector into the matchin socket description !!

115 End X = Endswitch X (opto sensor)
End Y = Endswitch Y (opto sensor)
Z sensor cable has no label

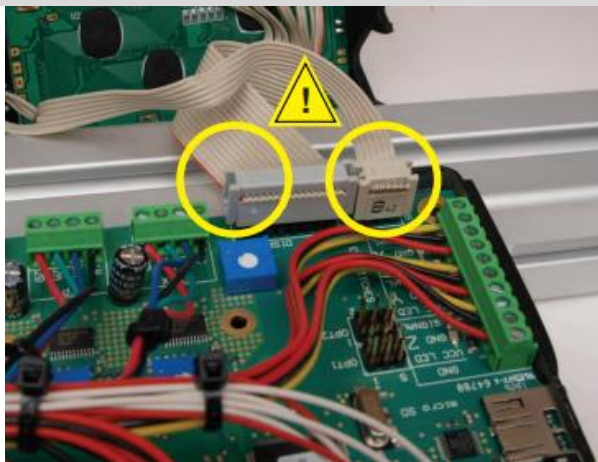

116 (1x) Display interface PCB
(1x) Display Assembly

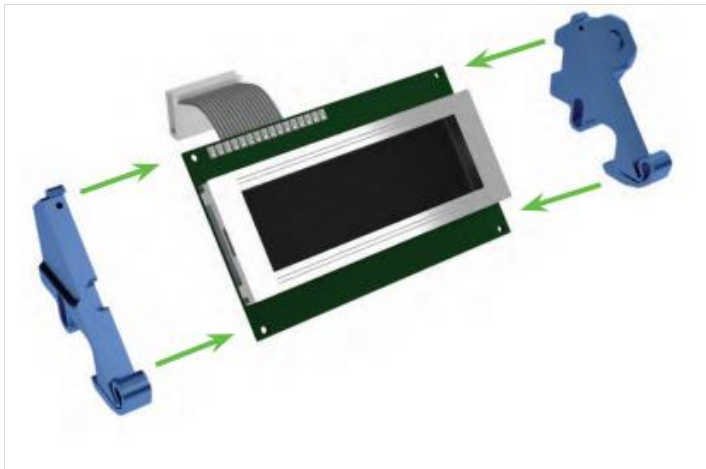

117



118 (2x) Small screw 2.2x8



119

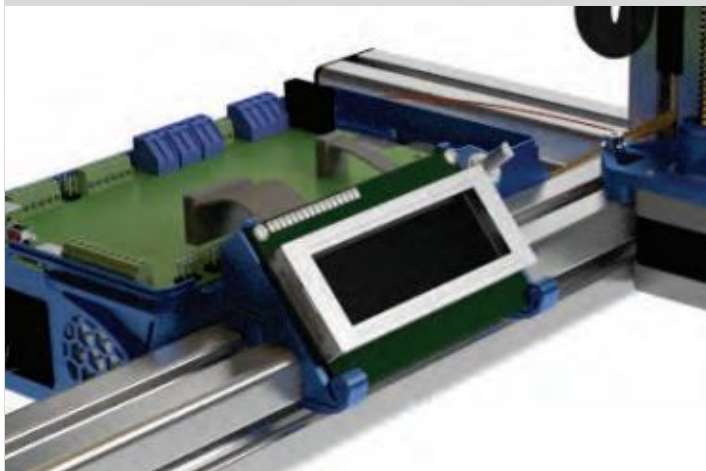

120

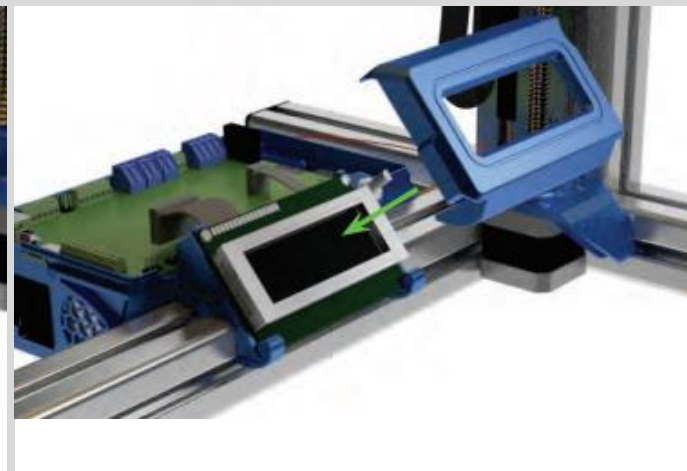

121

11 Upload Firmware

Download the Firmware:

Download the latest FELIX 3.2 firmware version from:

<https://www.felixprinters.com/downloads>

Upload the Firmware to the Control Board:

1. Unzip the downloaded file to a convenient location.
(Note: if you click on the zip file from within the Windows explorer, it will NOT be unzipped. You just view the content of the zip. You need to select the files and drag them to the desired location.)
2. Connect your printer to your computer and turn it on. Do not make a connection at this time with the printer with programs like Repetier-Host or Simplify3D.
3. Start the batch file "upload_automatic.bat". A script will start in a command window.
4. The script will try to detect what COM port your printer is using. Check if this is correct, and then proceed by entering 'Y' in the command window.
5. The firmware is uploaded when "Programming finished!" is displayed, this may take a few minutes.
6. Press any key to continue. The FELIX 3.2 firmware is now successfully uploaded.

Note for Experienced Users: Due to compatibility issues with linux based systems, the baudrate for all felixprinters are lowered to 115200. In case you are used to older FELIXprinter models, make sure to adjust the settings in the used software accordingly.

12 Functional Test

In order to make sure all motors, sensors and LCD panel are connected properly, the following tests need to be performed

Check Sensor Connections:

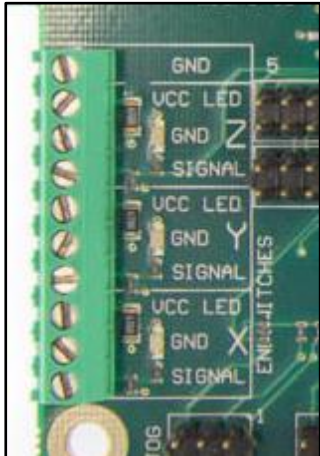

Main board FELIX 3.2

Z-sensor

The z-sensor can be tested by holding a metal object underneath the sensor. Check if the z-sensor LED turns off. When the z-sensor indication LED on the main board switches off, the sensor is activated.

Y-sensor

Manually move the bed to its end position to activate the y-sensor. Check if the y-sensor LED turns off. When the y-sensor indication LED on the main board switches off, the sensor is activated.

X-sensor

Manually move the extruder to its end position to activate the x-sensor. Check if the x-sensor LED turns off. When the x-sensor indication LED on the main board switches off, the sensor is activated.

Check Heaters:

IMPORTANT: Keep hand near ON/OFF switch of printer, in case things go wrong.

Warm up left extruder (E1).

Note: The hot-ends might smell a bit the first time heating. This is because of a small amount of oil within certain parts.

Click rotary button to enter the main menu --> Control --> scroll down to heater --> Click on E1 and rotate until setpoint temperature increases to about 100 °C. Then check if temperature for that heater goes up.

Repeat these steps for the right extruder (E2) and for the Bed (55 °C)

Check Motor Cable Connections:

IMPORTANT: Keep hand near ON/OFF switch of printer, in case things go wrong.

X-axis motor

To make sure the wires are connected as required it is important to test all connections.

To do so for the x-axis: enter menu by pushing the rotary button --> Control --> Move --> Home X

Y-axis motor

To test the y-axis: enter menu by pushing the rotary button --> Control --> Move --> Home Y

Z-axis motor

NOTE: When doing home z, extruders heat up to 120° C to prevent possible filament blobs from scratching the Kapton surface layer.

Important: ensure flex plate is placed on the print bed.

To test the z-axis: enter menu by pushing the rotary button --> Control --> Move --> Home Z

13 Finishing Touches

15 minutes

Tools:

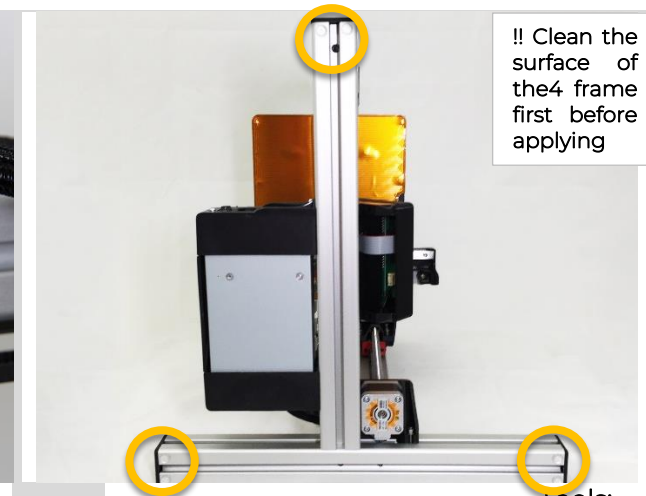

!! Clean the surface of the 4 frame first before applying

122

123 (1x) FELIX Tag

124 ((6x) Damping feet

Tools:

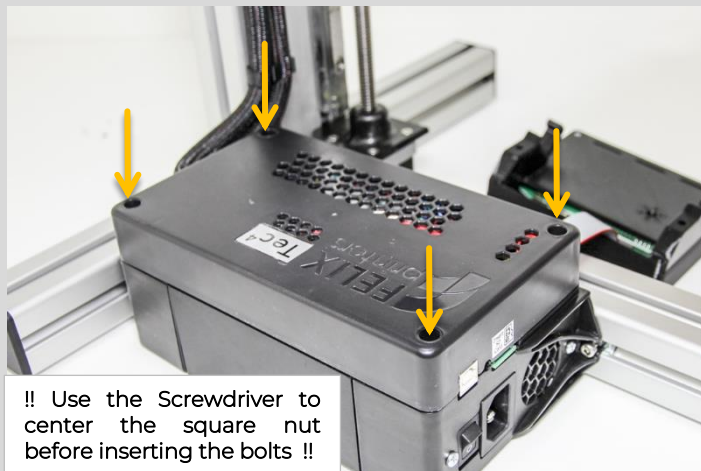

!! Use the Screwdriver to center the square nut before inserting the bolts !!

125 (1x) Main Fan Cover
Connect the fan cover onto the extruder unit

126 (4x) M4 x 12
(1x) Electronic Enclosure Cover

Tools:

+ 3

127

Tools:

Preheat your buildplate to 60 °C
To make sure the Kapton foil will have good
adhesion to the flexible plate

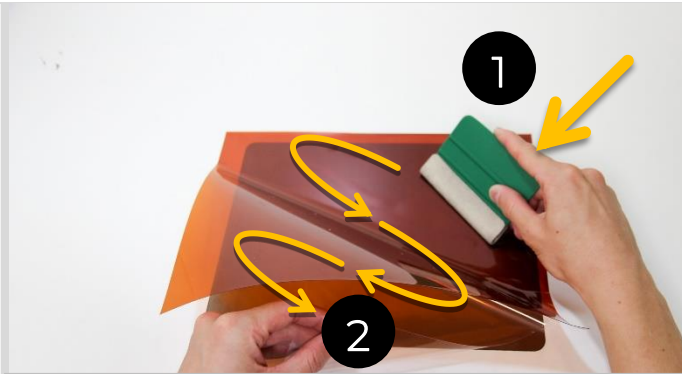

!! Continue peeling off the protective sheet and at the same
time stick the foil to the Build Plate using a soft object in a
zigzag motion to avoid air bubbles !!



128

129

(1x) Kapton Foil

130

Tools:



14 Checklist

	Frame	Check		Build platform	Check
1.	Frame bolts (6x) are properly fixed.		1.	Bolt (1x) center of build platform is properly fixed.	
2.	Frame profiles are perpendicular and propely aligned.		2.	Build surface doesn't contain air bubbles.	
3.	Damping feet are placed underneath the printer.			Print head	
	X-axis		1.	Extruder drive wheels properly aligned.	
1.	X-axis rail is properly aligned.		2.	Bolts (2x) connecting print head to X-axis carriage are properly fixed.	
2.	Bolts (2x) X-axis rail are properly fixed.		3.	Bolts (2x) sensor bracket are properly fixed.	
3.	X-axis belt pushed fully into bracket and tensioner.			Electrical	
4.	Belt remains at same height during moving the X-axis.		1.	Wire harness properly fixed without rubbing against parts.	
5.	Set screw (1x) for pulley is fixed at the correct height with set screw		2.	Wire harness loop for X, Y, Z-axis are at the correct length	
6.	X-axis belt tensioned properly		3.	do not get pulled under full extension.	
	Y-axis		4.	Cables are not under tension and have enough slack.	
1.	Bolts for stacked bearings (4x) guiding the belt are properly fixed		5.	Cable ties neatly cut off.	
2.	Y-axis carriage is properly aligned in the Z-axis lift.		6.	Connectors properly connected in sockets.	
3.	Bolts (4x) of the Y-axis carriage are properly fixed.		7.	Potentiometers on control board are set to the correct values.	
4.	Y-axis belt pushed fully into bracket and tensioner.		8.	Control board contains the correct FELIX 3.2 firmware version.	
5.	Belt remains at same height during moving the Y-axis.		9.	Wire colors are according to diagram.	
6.	Set screw (1x) for pulley is fixed at the correct height with set screw			Online Tests	
7.	Y-axis belt tensioned properly.		1.	Build platform heats up to 90 degrees C, move cable harness to check for wire breakage.	
	Z-axis		2.	Extruders heat up to 90 degrees C, move cable harness to check for wire breakage.	
1.	Z-axis rail is properly aligned.		3.	Hot-ends don't move during loading/unloading filament.	
2.	Bolts (3x) Z-axis rail are properly fixed.		4.	Check if filament gets pulled through firmly	
3.	Set screw (1x) Z-axis spindle is properly fixed.				
4.	Bolts (4x) connecting Z-axis carriage to the lift are propely fixed				
5.	Z-axis spindle nut is properly fitted in the Z-axis lift.				
6.	Z-axis spindle is greased over its entire length.				

Congratulations!

You have finished building the FELIX 3.2.

Continue to the Quick Start Guide to start printing!

15 Bill Of Materials

15.1 FELIX 3.2 DIY Kit - Base parts - 105 014.1

#	Group name	Part No.	Part description	Quantity
	Catalog/mechanical part	135 062.0	Hiwin Linear Ball Bearing - MGN12H1R0300Z1HM	2
	Catalog/mechanical part	135 002.0	Hiwin Linear Ball Bearing - HGW15CC1R300Z0	1
	Electronics Parts	150 023.0	Powersupply - FELIX Tec Series	1
	Sub assemblies (products with BOM)	105 050.0	Frame profile set Felix3/ Tec	1
	Sub assemblies (products with BOM)	105 016.3	Felix 3.2 bolts & nuts set	1
	Fasteners	140 036.0	M3 x 4 - HEX Set screw - DIN 916	3
	Fasteners	140 011.0	M3 x 6 - Set screw - DIN 916	4
	Fasteners	140 012.0	M3 x 6 - HEX CSK - DIN 7991	5
	Fasteners	140 013.0	M3 x 8 - HEX CSK - DIN 7991	15
	Fasteners	140 016.0	M3 x 12 - HEX SOCKET - DIN 912	5
	Fasteners	140 017.0	M3 x 16 - HEX SOCKET - DIN 912	18
	Fasteners	140 018.0	M4 x 12 - HEX SOCKET - DIN 912	12
	Fasteners	140 019.0	M4 x 16 - HEX SOCKET - DIN 912	4
	Fasteners	140 020.0	M4 x 20 - HEX SOCKET - DIN 912	15
	Fasteners	140 021.0	M4 x 25 - HEX SOCKET - DIN 912	6
	Fasteners	140 022.0	M4 x 40 - HEX SOCKET - DIN 912	6
	Fasteners	140 023.0	M5 x 16 - HEX SOCKET - DIN 912	5
	Fasteners	140 024.0	M3 - Washer - DIN125A	10
	Fasteners	140 025.0	M4 - Washer - DIN125A	22
	Fasteners	140 026.0	M5 - Washer - DIN125A	5
	Fasteners	140 028.0	M4 - Large Washer Carrosserie ring (4,3) - LL NF E25-513	2
	Fasteners	140 029.0	M3 - HEX LOCK NUT - DIN 985	6
	Fasteners	140 030.0	M4 - HEX LOCK NUT - DIN 985	8
	Fasteners	140 031.0	M4 - HEX THIN NUT - DIN 439B	10
	Fasteners	140 032.0	6/32 x 1/4 - Pozi steel - Powersupply screw - UNC	4
	Fasteners	140 037.0	M4 x 30 - HEX Set screw - DIN 916	2

	Fasteners	140 038.0	M3 x 30 - HEX SOCKET - DIN 912	4
	Fasteners	140 039.0	Spring Extruder & bed	4
	Fasteners	140 040.0	M4 - THIN SQUARE NUT - DIN 562	9
	Printer Frame Parts	110 114.0	T-hammer nut M3 for 40 serie profile	3
	Packaging Material	200 013.0	Assortment box 18 compartments, 210x120x36	1
	Fasteners	140 070.0	2.2 x 9.5 - Parker - plaatschroef - DIN 7981F	6
	Sub assemblies (products with BOM)	105 052.2	Mechanic bag felix3.2 diy	1
	Catalog/mechanical part	135 004.0	Pulley - HTD 3M - 14T - W6 - ID5 - Felix 3/Tec/Pro	2
	Catalog/mechanical part	135 003.0	Tooth Belt (HTD - 3M - 6mm)	1,6
	Catalog/mechanical part	135 005.0	bearing 624, 4x13x4	7
	Extruder mechanical parts	130 141.0	Extruder drive wheel FELIX Pro	1
	Machined parts	130 035.0	Platform support - Tec4 - (Y-Bracket Tec 4) - 03125_3	1
	Machined parts	130 041.0	Knurled thumb knob - Tec4 - 03129_2	2
	Extruder mechanical parts	130 147.0	Extruder cable flange - TEC 4.1 - 03162_0	1
	Sub assemblies (products with BOM)	105 051.0	Frame bag FELIX 3/ Tec4	1
	Printer Frame Parts	110 017.0	frame connector set	6
	Printer Frame Parts	110 018.0	handle PA 160 for Felix3	1
	Printer Frame Parts	110 019.0	Protective cap, handle PA160, FELIX 3	1
	Printer Frame Parts	110 022.0	T-Slot Nut V 8 St M4	12
	Printer Frame Parts	110 024.0	T-Slot Nut V 8 St M8	2
	Printer Frame Parts	110 015.0	40x40 protective caps	4
	Printer Frame Parts	110 016.0	80x40 protective caps	1
	Printer Frame Parts	110 025.0	damping foot (felix 3)	6
	Fasteners	140 035.0	M8 x 16 - HEX BUTTON - ISO 7380	2
	Packaging Material	200 025.0	Gripzakken 200 X 300 mm	1
	Sub assemblies (products with BOM)	105 006.4	Hot-End - 3 series	1
	Mechanical hotend parts	130 019.4	Hot-End Base FELIX 3	1
	Mechanical hotend parts	130 021.4	FELIX 3 - Hot-End Peek Isolation	1
	Mechanical hotend parts	130 023.3	Heated Barrel FELIX 3 (standard M8)	1
	Mechanical hotend parts	130 024.1	Nozzle 0.35mm - Brass - FELIX 3 - 03149_3	1

	Fasteners	140 036.0	M3 x 4 - HEX Set screw - DIN 916	2
	Electronics Parts	150 162.0	FELIX 3.1 & Tec4 - Thermistor incl. connector	1
	Electronics Parts	150 013.0	Felix 3 & Tec 4 - Heater Cartridge incl. connector	1
	Sub assemblies (products with BOM)	105 053.2	Electronics bag Felix 3.2 - DIY kit	1
	Cabling & optosensing	150 155.0	Opto sensor X (Straight) FELIX 3/Tec4 incl connector	2
	Cabling & optosensing	150 156.0	Opto sensor Y (Angle) FELIX 3/Tec4 incl connector	1
	Electronics Parts	150 025.0	Cooling fan - 40 x 40 x 10 mm	2
	Miscellaneous	170 021.0	Cable ties for mounting cables on Z bracket	2
	Miscellaneous	170 015.0	Cable sleeve, nylon semi open set 95/ 115 cm	2,1
	Cabling & optosensing	150 150.0	Stepper Extruder cable Tec4	1
	Cabling & optosensing	150 152.0	Stepper X-axis cable Tec4	1
	Cabling & optosensing	150 153.0	Stepper Y-axis cable Tec4	1
	Cabling & optosensing	150 154.0	Stepper Z-axis cable Tec4	1
	Sub assemblies (products with BOM)	105 128.0	set Tie wraps 20 (100x2.5mm) pieces in bag	1
	Miscellaneous	170 013.0	cable ties, tie wrap - 100mm x 2.5 mm	20
	Packaging Material	200 022.0	Gripzakken 45 X 110 mm	1
	Sub assemblies (products with BOM)	105 025.0	LCD panel base for FELIX 3	1
	Electronics Parts	150 028.0	Display 20x4 lines, 20x4 transreflective STN blue/white	1
	Electronics Parts	150 033.0	click-encoder (Incremental encoder WITH detent 24 pulses)	1
	Cabling & optosensing	150 029.0	Flat cable grey 24-way (piece of 10cm) 30.4 m	0,2
	Electronics Parts	150 030.0	IDC connector 6-pin F	1
	Electronics Parts	150 031.0	IDC Ribbon Cable Socket 16 way	1
	Fasteners	140 070.0	2.2 x 9.5 - Parker - plaatschroef - DIN 7981F	2
	Sub assemblies (products with BOM)	105 019.0	Miscellaneous Bag - DIY kit	1
	Cabling & optosensing	150 018.0	USB cable 1.8m	1
	Miscellaneous	170 011.0	Tweezers	1
	Miscellaneous	170 019.1	Teflon Tube for Pro and 3 series - (55cm)	1
	Miscellaneous	170 023.1	Filament dust cleaner	1
	Filaments - Consumables	180 001.1	PLA sample - 50 gram - Random Colours	1
	Plastic Parts Felix 3 / Tec4	122 045.0	Filament guide/ dust cleaner holder Felix3/ Tec (printed)	1

	Production Consumables & materials	A-00548	Production PLA BLACK (1 kg)	0,05
	Plastic Parts Felix 3 / Tec4	122 044.1	Filament bracket Tec (printed) black	1
	Production Consumables & materials	A-00548	Production PLA BLACK (1 kg)	0,05
	Packaging Material	200 035.0	Calibration card	1
	Sub assemblies (products with BOM)	105 055.0	Set motors for diy kit	1
	Electronics Parts	150 027.1	Stepper motor - Nema 17 - 40 mm	4
	Sub assemblies (products with BOM)	105 127.0	Build platform assembly Felix Tec/One/3.2	1
	Machined parts	130 034.4	bare sandwich plate (heated bed) - F3 and TEC4 - 03127_4	1
	Electronics Parts	150 132.0	Foil heater Felix Tec4	1
	Catalog/mechanical part	135 055.1	Magneet 8x5 Nickel Plated (heated bed)	12
	Machined parts	130 037.0	Build Platform sticker - Tec4 - 03138_0	1
	Machined parts	130 025.2	Aluminum insert for sandwich table - F3 & Tec - 03141_0	1
	Printed circuit control boards	150 037.0	Controlboard Felix Tec4	1
	Packaging Material	200 041.0	Insteekhoes verpakking (A5 transparant hersluitbaar)	1
	Sub assemblies (products with BOM)	105 056.1	spindle & nut combi	1
	Machined parts	130 017.0	Spindle - trapezium - Felix 3/Tec4/One - 03224_0	1
	Machined parts	130 018.0	Trapezium hexagon nut TR10x2 - Tec - 03225_0	1
	Machined parts	130 032.0	Flex plate - Tec4 - 03130_1	1
	Miscellaneous	170 024.0	Kapton sticker 270 mm x 300 mm (PRO/TEC)	1
	Packaging Material	200 051.0	Verpakking 3D printer bed	1
	Sub assemblies (products with BOM)	105 025.0	LCD panel base for FELIX 3	1
	Electronics Parts	150 028.0	Display 20x4 lines, 20x4 transfective STN blue/white	1
	Electronics Parts	150 033.0	click-encoder (Incremental encoder WITH detent 24 pulses)	1
	Cabling & optosensing	150 029.0	Flat cable grey 24-way (piece of 10cm) 30.4 m	0,2
	Electronics Parts	150 030.0	IDC connector 6-pin F	1
	Electronics Parts	150 031.0	IDC Ribbon Cable Socket 16 way	1
	Fasteners	140 070.0	2.2 x 9.5 - Parker - plaatschroef - DIN 7981F	2

15.2 FELIX 3.2 Single to Dual Upgrade Kit - 105 031.0

#	Group name	Part No.	Part description	Quantity
	Extruder mechanical parts	130 141.0	Extruder drive wheel FELIX Pro	1
	Extruder mechanical parts	130 044.0	Dual Extruder Front Bracket - Tec 4	1
	Extruder mechanical parts	130 043.0	Z-adjustment right hot-end - Tec 4	1
	Fasteners	140 017.0	M3 x 16 - HEX SOCKET - DIN 912	4
	Fasteners	140 022.0	M4 x 40 - HEX SOCKET - DIN 912	3
	Fasteners	140 029.0	M3 - HEX LOCK NUT - DIN 985	1
	Fasteners	140 030.0	M4 - HEX LOCK NUT - DIN 985	2
	Fasteners	140 039.0	Spring Extruder & bed	1
	Fasteners	140 040.0	M4 - THIN SQUARE NUT - DIN 562	2
	Electronics Parts	150 027.1	Stepper motor - Nema 17 - 40 mm	1
	Miscellaneous	170 019.1	Teflon Tube for Pro and 3 series - (55cm)	1
	Miscellaneous	170 023.1	Filament dust cleaner	1
	Sub assemblies (products with BOM)	105 006.4	Hot-End - 3 series	1
	Mechanical hotend parts	130 019.4	Hot-End Base FELIX 3	1
	Mechanical hotend parts	130 021.4	FELIX 3 - Hot-End Peek Isolation	1
	Mechanical hotend parts	130 023.3	Heated Barrel FELIX 3 (standard M8)	1
	Mechanical hotend parts	130 024.1	Nozzle 0.35mm - Brass - FELIX 3 - 03149_3	1
	Fasteners	140 036.0	M3 x 4 - HEX Set screw - DIN 916	2
	Electronics Parts	150 162.0	FELIX 3.1 & Tec4 - Thermistor incl. connector	1
	Electronics Parts	150 013.0	Felix 3 & Tec 4 - Heater Cartridge incl. connector	1
	Fasteners	140 018.0	M4 x 12 - HEX SOCKET - DIN 912	2
	Fasteners	140 031.0	M4 - HEX THIN NUT - DIN 439B	2
	Catalog/mechanical part	135 005.0	bearing 624, 4x13x4	1
	Cabling & optosensing	150 150.0	Stepper Extruder cable Tec4	1
	Plastic Parts Felix 3 / Tec4	122 021.0	Extru_F3_0_arm_pt1_v1 - black	1
	Plastic Parts Felix 3 / Tec4	122 022.0	Extru_F3_0_arm_pt2_v1 - black	1
	Plastic Parts Felix 3 / Tec4	122 020.1	Extru_F3_1_L_shape_bracket - black	1
	Fasteners	140 066.0	M4 x 20 - HEX BUTTON - ISO 7380	4

	Electronics Parts	150 159.0	Double fan with cable and connector Tec4	1
	Electronics Parts	150 025.0	Cooling fan - 40 x 40 x 10 mm	2
	Sub assemblies (products with BOM)	105 128.0	set Tie wraps 20 (100x2.5mm) pieces in bag	1
	Miscellaneous	170 013.0	cable ties, tie wrap - 100mm x 2.5 mm	20
	Packaging Material	200 022.0	Gripzakken 45 X 110 mm	1
	Plastic Parts Felix 3 / Tec4	122 023.3	Air duct Felix 3.2 - dual head - Black ABS-X	2
	Filaments - Consumables	A-00566	Production ABS BLACK 1kg	
	Catalog/mechanical part	135 054.0	Magnets schijf 8x8 (bed)	2

15.3 Set Plastic parts Felix 3.2 - 105 047.1

#	Group name	Part No.	Part description	Quantity
	Plastic Parts Felix 3 / Tec4	122 012.0	X_stage_F3_0_belt_mount_v1 - black	1
	Plastic Parts Felix 3 / Tec4	122 011.0	X_stage_F3_0_motor_bracket_v1 - black	1
	Sub assemblies (products with BOM)	105 064.0	Y stage bracket prt1 with inserts Felix Tec4 Black	1
	Plastic Parts Felix 3 / Tec4	122 013.1	Y_stage_F3_1_Bracket pt1 - black	1
	Fasteners	140 065.0	M4 - Insert Type 19 Long	1
	Sub assemblies (products with BOM)	105 065.0	Y stage bracket prt2 with inserts Felix Tec4 Black	1
	Plastic Parts Felix 3 / Tec4	122 014.1	Y_stage_F3_1_Bracket pt2 - black	1
	Fasteners	140 065.0	M4 - Insert Type 19 Long	1
	Plastic Parts Felix 3 / Tec4	122 215.0	Y_stage_F3_0_tensioning_bracket_v1 - blue	2
	Plastic Parts Felix 3 / Tec4	122 016.0	z_axis_F3_0_lift_part_v1 - black	1
	Plastic Parts Felix 3 / Tec4	122 017.0	z_axis_F3_0_motor_bracket_v1 - black	1
	Plastic Parts Felix 3 / Tec4	122 018.1	z_axis_F3_1_limitswitch_vane - black	1
	Plastic Parts Felix 3 / Tec4	122 019.1	Extru_F3_1_base - black	1
	Plastic Parts Felix 3 / Tec4	122 020.1	Extru_F3_1_L_shape_bracket - black	2
	Plastic Parts Felix 3 / Tec4	122 021.0	Extru_F3_0_arm_pt1_v1 - black	1
	Plastic Parts Felix 3 / Tec4	122 022.0	Extru_F3_0_arm_pt2_v1 - black	1
	Plastic Parts Felix 3 / Tec4	122 023.2	Air duct Felix 3.2 - single head - Black ABS-X	1
	Filaments - Consumables	A-00566	Production ABS BLACK 1kg	0,02

	Plastic Parts Felix 3 / Tec4	122 024.0	Extru_F_3_0_hot_end_clamp_v1 - black	1
	Plastic Parts Felix 3 / Tec4	122 025.0	Electronics_enclosure_F3_0_cap_pt1 - black	1
	Plastic Parts Felix 3 / Tec4	122 026.0	Electronics_enclosure_F3_0_cap_pt2 - black	1
	Plastic Parts Felix 3 / Tec4	122 027.0	Electronics_enclosure_F3_0_cover_v1 - black	1
	Plastic Parts Felix 3 / Tec4	122 030.0	Printed parts LCD panel FELIX 3, Black	1
	Production Consumables & materials	A-00548	Production PLA BLACK (1 kg)	0,1
	Plastic Parts Felix 3 / Tec4	122 042.0	cable clips set printed ABS	1
	Filaments - Consumables	A-00566	Production ABS BLACK 1kg	0,05
	Plastic Parts Felix 3 / Tec4	122 047.0	Fan front cover Felix 3.2 - single - black	1
	Production Consumables & materials	A-00548	Production PLA BLACK (1 kg)	0,05