

## Instruction manual

### Felix 1.5, 3d printer-kit

Version1 - 20-Oct-2012

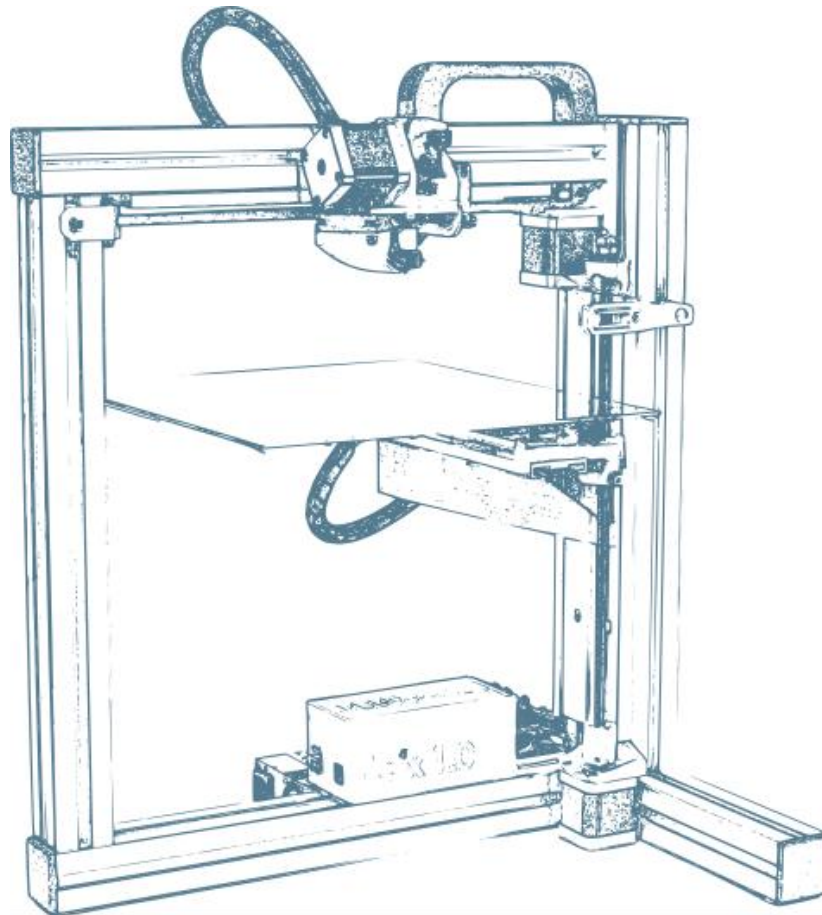

#### Copyright Information

This document contains proprietary information that is protected by copyright. No part of this document may be photocopied, reproduced, or translated to another language without the prior written consent of FELIXrobotics.

#### FelixRobotics

Hoogstraat 421H  
5654NE Eindhoven  
Netherlands

Copyright © 2012 FELIXrobotics.

## Table of contents

### Contents

Table of contents .....	2
1 Introduction.....	4
2 Required toolset .....	4
3 Required skills.....	5
4 Important note .....	5
5 Module 1: Frame (time: 10-30 minutes).....	6
6 Module 2: Z-axis (time: 45-90 min.).....	10
7 Module 3: The Extruder (time: 30-90 min.) .....	16
8 Module 3: The X-axis (time: 30-60 min.).....	21
9 Module 5: Table (time: 1-2 hours).....	25
10 Module 6: Y-axis (time: 10-30 min.).....	27
11 Module 7: Electronics (time: 2-4 hrs.) .....	31
11.1 Mount the powersupply.....	33
11.2 Connect all possible wires to the electronics board.....	35
11.3 Connect the opto-sensors .....	36
11.4 Connect the motor wires.....	37
11.5 Connect the y-axis table wires to the board. ....	38
11.6 Connect the rest of the wires.....	39
11.6.1 Wires for the hot-end.....	39
11.6.2 The 3 fans.....	39
11.7 Clean it up.....	39
12 Finishing touches (time: 30-45 min.).....	42
13 Calibration of table (5-15 mins).....	44
14 Making printer ready for operation. (30 – 60 mins) .....	45
14.1 Firmware installation .....	45

# FELIXPrinters

---

14.2	Printer software – Repetier-Host.....	47
14.3	Calibrate the Z-direction/ Connect to printer .....	52
15	It's time for printing! (15- 30mins).....	54
16	Quest to high quality printing .....	56
16.1	Thermodynamics .....	56
16.2	Mechanics.....	56
16.3	Software.....	57
17	FAQ.....	57
18	BOM Felix 1.0 Revision D .....	58

# FELIXPrinters

## 1 Introduction

First of all thank you choosing FELIXprinters! To get your Felix printer up and running as fast and painless as possible please follow this manual. When things are unclear or if you have any remarks or tips, please contact us at [info@felixprinters.com](mailto:info@felixprinters.com). We also recommend looking on our forum and get yourself a forum account. You will benefit from the ability to get downloadable and printable upgrades for your printer. Also it is a great source to obtain more knowledge about your printer and printing in general.











Depending on your skills this kit will take approximately 6-12 hours to assemble and to make your first print. Please read the manual carefully and follow it step by step. Please don't make any shortcuts unless you know what you're doing. It's better to spend a few minutes extra on reading, than to wait a week for new parts.

The manual is build up as follows: Each module starts with a short introduction. After that a Bill of Materials (BOM) is presented. The BOM doesn't contain the small bolts and nuts, because for the assembly of the printer the assortment box of bolts and nuts is required. Further to not bloat the manual, a picture of each part is only displayed in the complete BOM of the printer. This can be found in the Supplement of the document.

Before starting the build of your printer, it's recommended to check if all parts are present by comparing it with the bill of materials.

## 2 Required toolset

The following tools are minimally required to assemble and use the Felix printer

File	
Wrenches 7 and 13mm	
Tweezers. (included in kit)	
Nippers.	
Caliper	
Allen Key set. <b>IMPORTANT:</b> they need to be preferably long and have a round head at the end.	
Pliers	
Drill with a variable speed. When plastic parts need to be drilled out, it should be done with care	
Level	
Drill bits 2mm, 4mm	



# FELIXPrinters

Hammer	
Soldering iron including flux and soldering tin	
Wire stripper, recommended	

### 3 Required skills

The following skills are required to put the Felix printer together:

- Basic soldering skills
- Skills to assemble a mechanical construction
- Technical insight
- Common sense

If you lack any of these skills or are unsure please get help from someone who can guide you or do this for you

### 4 Important note

To save paper the flow of the document is built up as follows:

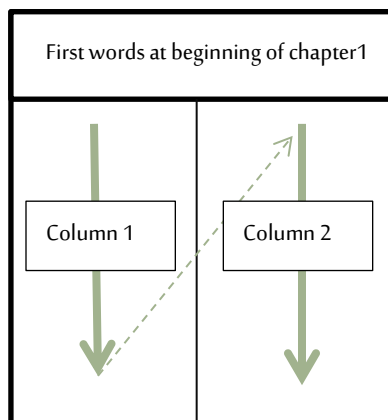

## 5 Module 1: Frame (time: 10-30 minutes)

Required for this module

### Tools

- Allen key set
- Level reference surface
- Level

### Parts

- Bag with description 'frame module'.
- Aluminum beams.



Overview of frame module

The goal of this module is to create the frame on the right. Try to make everything as perpendicular as possible to each other. Let surfaces align as good as possible. A good idea is to use a level tool.

BOM for frame module	
Part	Amount
40x40x400 profile, incl 2xM8	1
40x40x400 profile, incl 1xM8, 1xD7	2
40x40x400 profile, incl 3xD7	1
80x40x440 incl work	1
40x40 protective caps	4
80x40 protective caps	1
frame connector set	6
handle incl protective cap	1
hex sockethead bolt M6x1	2
t-slot nut - 8 ST M6	2
t-slot nut - 8 ST M4	22
dampning feet	6
strip for putting away cable pieces of 40 cm	2

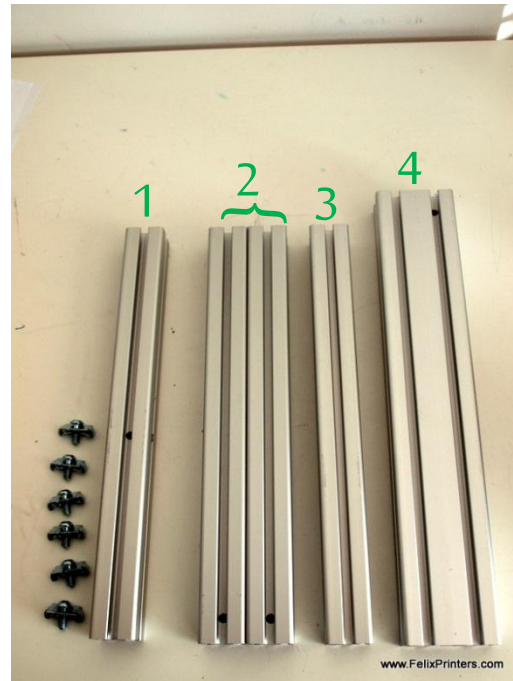

Collect the parts shown above. Notice the holes in the beams.

To make it understandable, the beams are described as follows:

Beam 1: 40x40x400mm beam, has 3 drilled holes

Beam 2: 40x40x400mm beam, has 1 drilled hole and one thread at the far end of the beam

Beam 3: 40x40x400mm beam, has 2 threads at the far ends.

Beam 4: 80x40x440mm beam has one drilled hole and one thread at the bottom.

Some of the beams have a screw thread on the far ends of the beam.

These are present for the frame connectors.

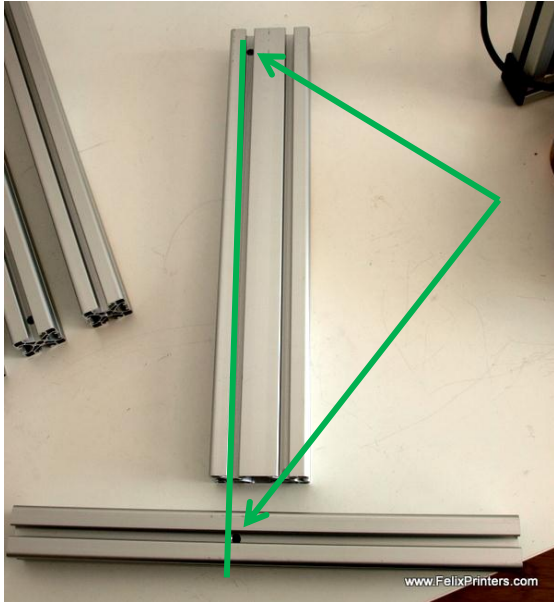

Take beam 4 and 1. They must be connected as oriented in the above picture.



Screw the frame connectors in the bottom of beam 4 as indicated in the figure. Then slide beam 4 onto beam 1.

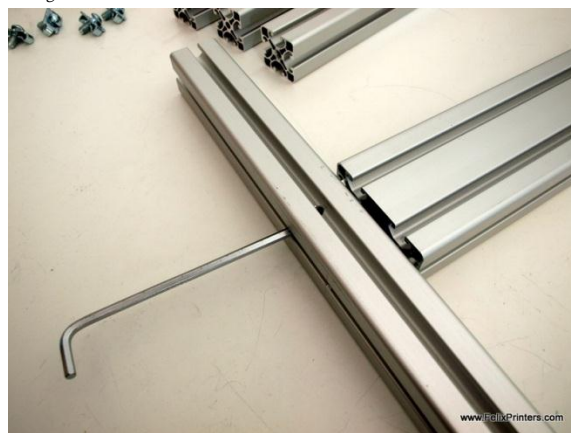

Slide beam 4 in position. On the side of beam 1 where the hex-key is positioned there are two drilled holes. Tighten the frame connectors by

sticking the hex-key through the holes. Do not fix it too tight because fine-tuning/leveling is needed later on.



Slide one of the two beams number 2 onto beam 1. Watch the orientation of the drilled hole.

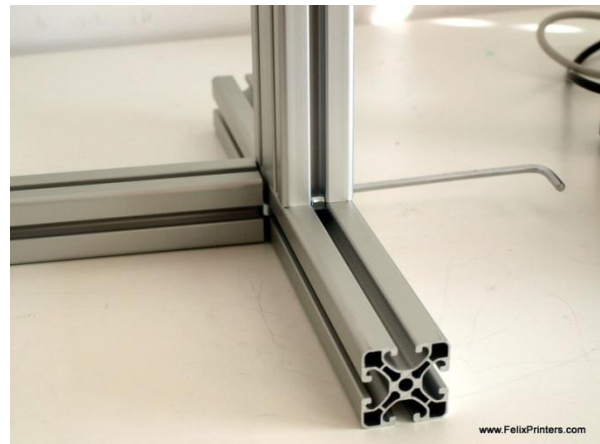

Turn the frame and fix beam 2 onto beam 1. Again not too tight.



Take beam 3. Screw both frame connectors on the far-ends. Slide it onto beam 2 and tighten it.



Take beam 2 again and screw the frame connector on its far end. Then slide it on beam 3 as indicated on the picture.



Next try to slide it also on beam 4.



Tighten the screws, again not too tight.



Now it is time for fine-tuning. Try to get every beam as level as possible. Also align the beams as good as possible. See an example in the picture below

Topview of frame

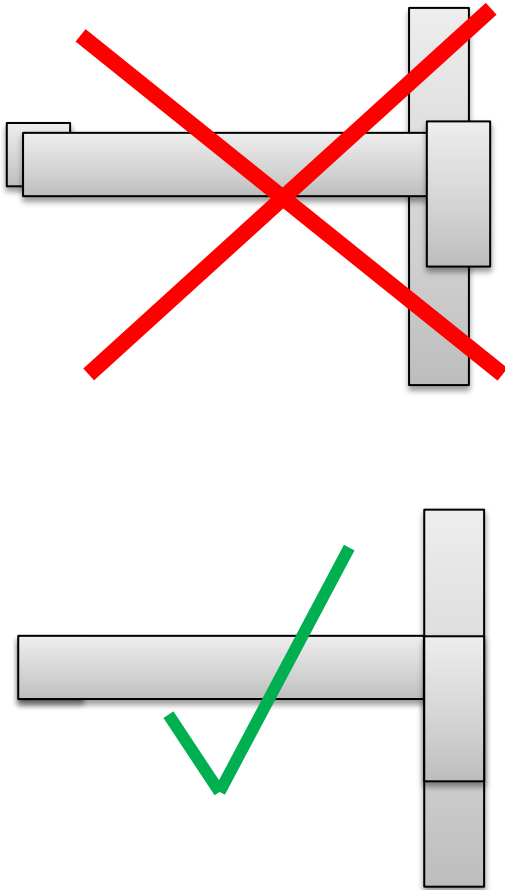

Get the protective caps and mount them carefully with a hammer

When all the beams are aligned and leveled, it is time to firmly tighten the frame connectors.

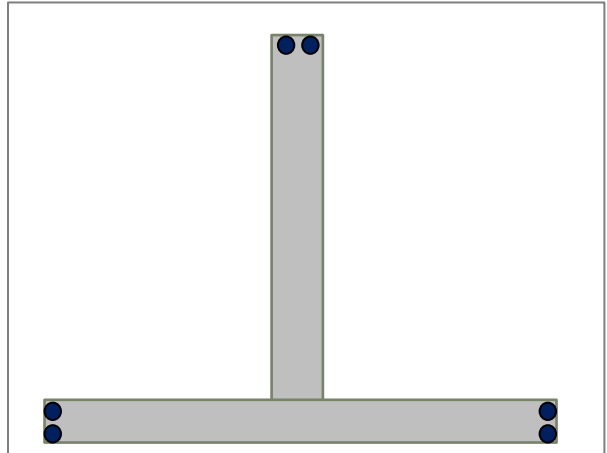

Put the damping foots underneath the frame near the edge

The handle should be mounted in the final stages of assembly.



## 6 Module 2: Z-axis (time: 45-90 min.)

Note: Most holes are designed to minimize the need for any post processing, like filing and drilling. Sometimes, however the bolts will not fit and it therefore needs to be drilled out slightly. Required drill sizes can be 3, 4 mm.

**!! Do following steps before starting the rest of the module: !!**

- **File a flat side on the motor axle for the all 4 motors. They all need a flat side to mount a pulley, extruder wheel or coupling to them by means of a set-screw. The flat side needs to be 15mm high and approx. 1 mm deep.**
- **Tip: Connect all the motor wires ends together. This creates an electronic lock of the motor. This makes filing a flat side significantly easier.**

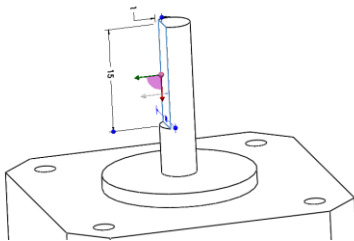
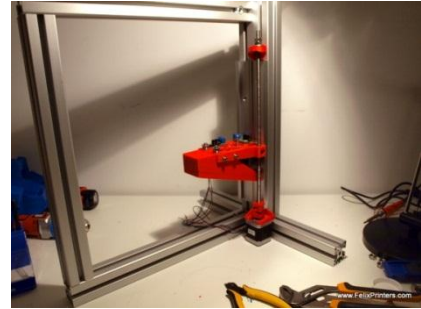

BOM Z-axis	
Part description	Amount
Igus GmbH_NS-01-80 - rail	1
Igus GmbH_NW-02-80 - cart	1
z-spindle	1
large bearing	1
motor nema 17	2
z-spindelmount bottom - v2	1
pulley_motor_HTD	1
z_axis_carrier_pt1_v9	1
z_axis_carrier_pt2_v5	1
z-axis-motor-bracket_v8	1
optosensor	2
z-axis-coupling-v11	1
small bearing	2
z-axis-limitswitch_vane_v4	1

Get the parts indicated in the list above.

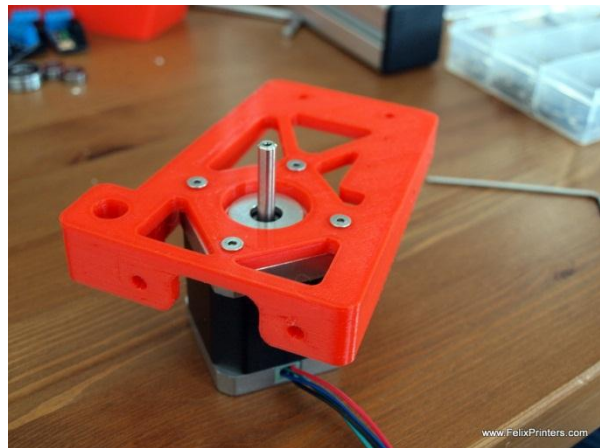

Get the part shown above and mount the (y-axis) motor onto it with the countersunk m3x8 bolts. **IMPORTANT: make sure the motor cables are oriented as in the picture.**

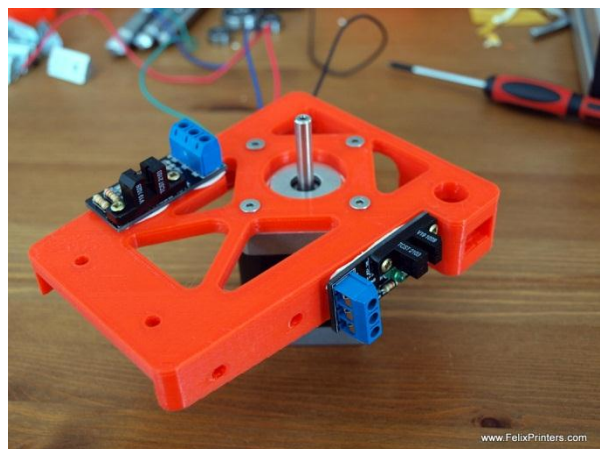

# FELIXPrinters

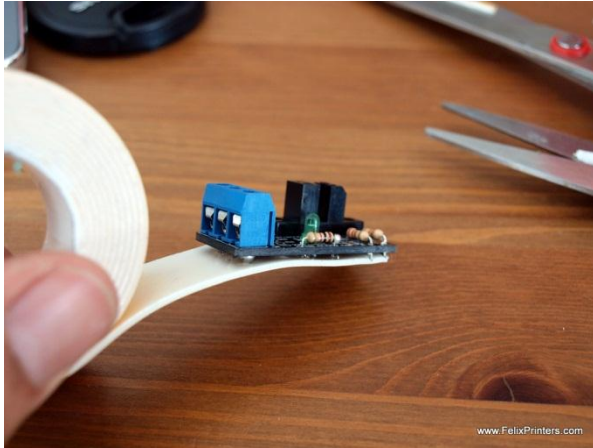

Put the provided double sided tape underneath the opto-sensors and mount them onto the printed part. Mount them with the small bronze screws. **NOTE: Don't screw it too tight, because that will deform the opto-sensor.**



If for any reason the inside of the bracket above is not smooth. Please smoothen the surface a little bit on the inside, with a small file.



Put the big bearing inside the z-spindle holder. It should be a tight fit and it can be pushed in. If it is difficult by hand, you can use pliers to push it in.

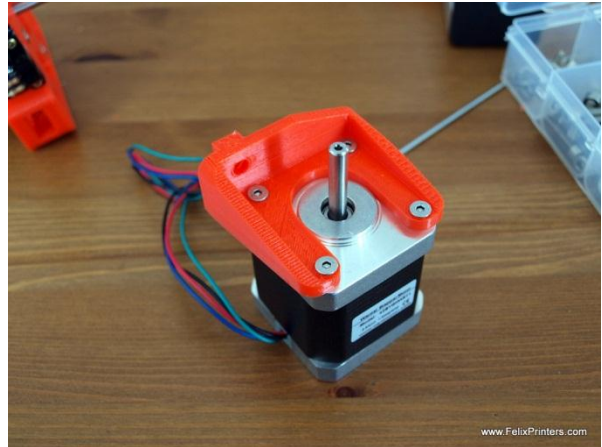

Mount the z-axis motor. **IMPORTANT: the cables must be oriented according to the picture.**

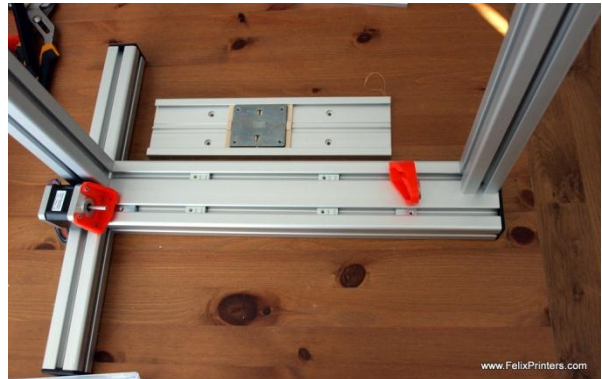

Get the frame and put it on its side as shown in the picture.

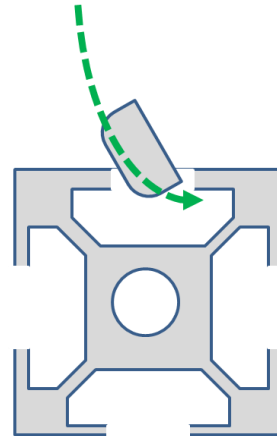

Cross-section of aluminum beam

Insert the t-slot nuts as indicated in the previous picture. Tilt the t-slot nut and push it in the frame approx. at the correct location. So, it is NOT necessary to disassemble the frame, to insert a t-slot nut. Once it is in, you can further position it with a small Allen-key.



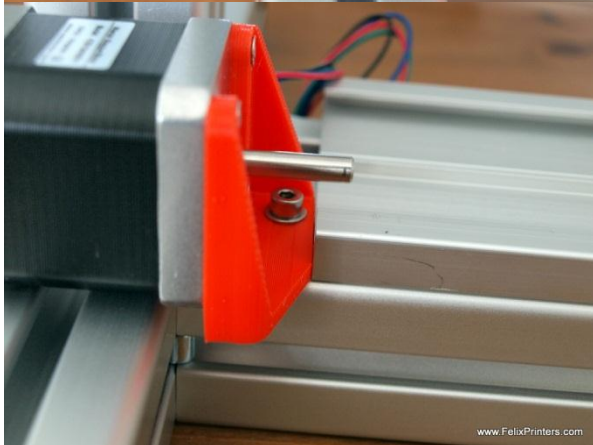

The bottom of the motor should be aligned with the bottom of the frame. Mount the z-motor bracket with a small washer and an M4x12 bolt. Do this correct, because it can save some extra work later on.

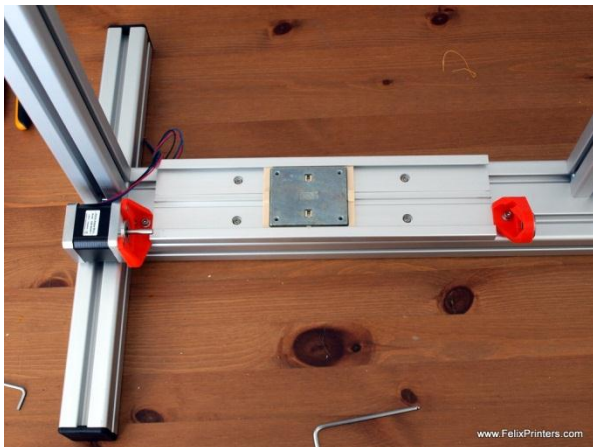

Mount the rail including slide onto the frame with 4 button head m4x12 bolts. Do NOT use washers in this case, otherwise the bolt head will touch the slider. Also important is that the rail should touch the z-motor bracket.



The z-spindle mount should also touch the rail. Use a small washer and an M4x16 bolt

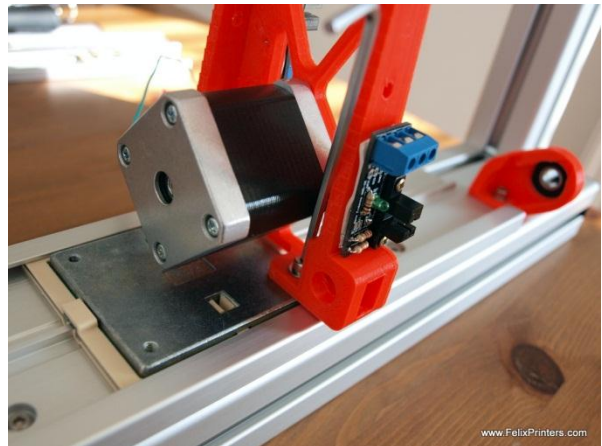

Mount the z-axis part onto the slider with two small washers and m4x12 bolts. Only tighten it loosely.

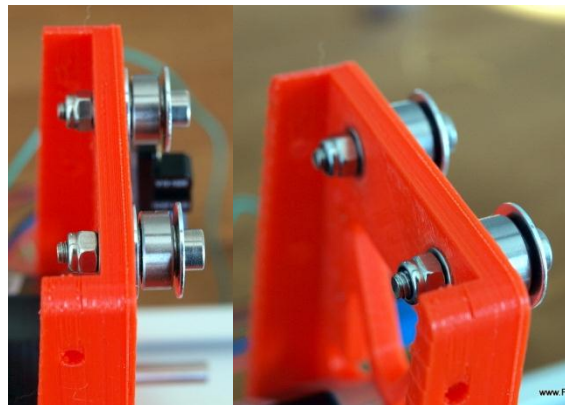

Mount the bearings which guide the y-axis tooth-belt. Order of washers and bearings, right to left:

M4x20 bolt, large washer, small washer, bearing, small washer, large washer, plastic part, small washer, self-locking M4 nut.

Fix it tightly, because it is difficult to reach later on.



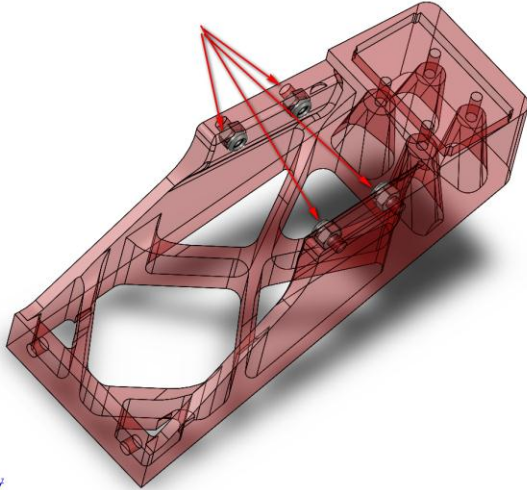

Place the M4 self-locking nuts in the big part as indicated above

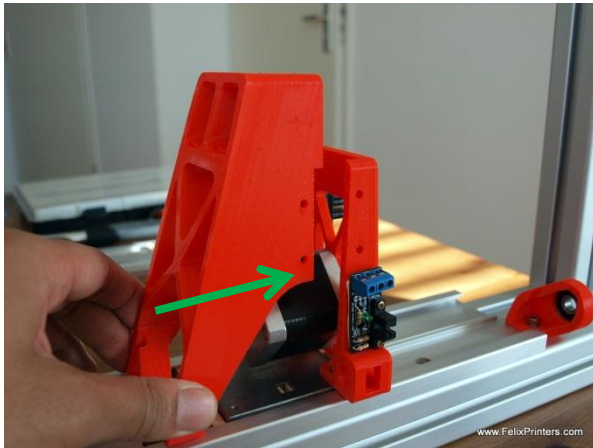

Slide the big z-axis carrier part onto the smaller z-axis carrier part as indicated in the picture above.

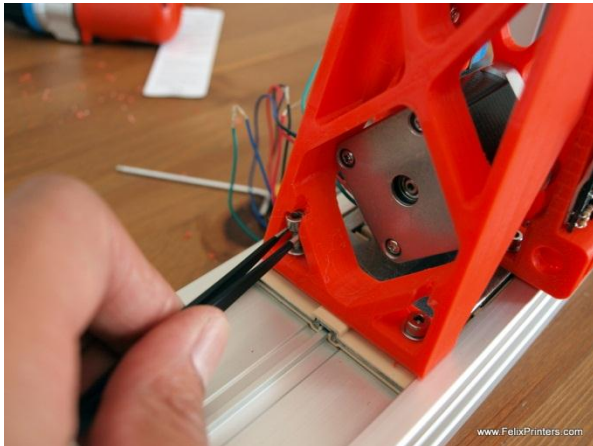

Mount the big part onto the z-axis carrier with small washers and m4x12 bolts. Tip: put the bolts in place with the supplied tweezers.



To further connect the two z-axis carrier parts, turn the frame upside down.

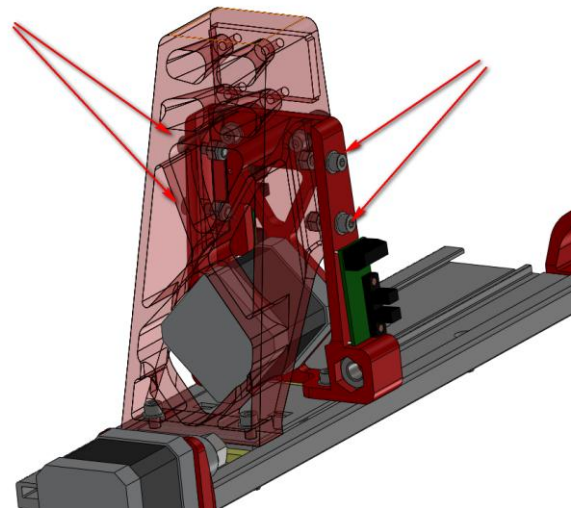

Mount the big part onto the other printed part. Use 4x M4x16 bolts with small washers.

NOTE: when turning the bolt into the nut, be sure it goes in straight. Otherwise it will push out the nut of the printed part. It should take a little torque to let it go through. Also keep your finger on the nut to be sure it doesn't fall out of the bracket.

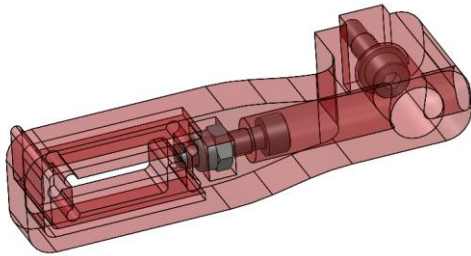

Pre-assemble the z-axis limit switch vane. Use a ring and M4x16 bolt for attachment to the frame. DO NOT mount it to the frame yet, because it is a delicate part it should be mounted in the final stages of assembly, otherwise the chances of damaging are very high.

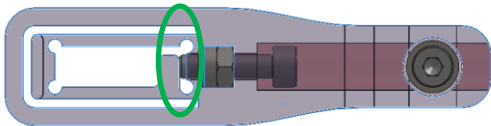

Slide in a self-locking nut into side. Then mount an M4x16 bolt. Let the tip of the bolt touch the flange as indicated in the picture.

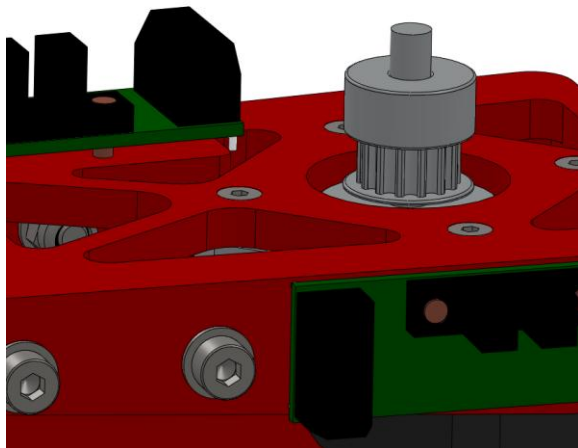

Mount the pulley upside down onto the motor-axis. The distance from the bottom of the pulley to the motor housing, should be approx. 2mm.

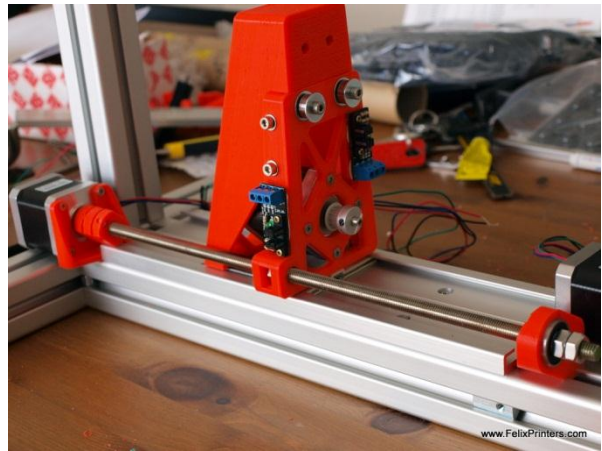

Place the rod with the coupling in place. See below for more instructions.

Do it in the following way:

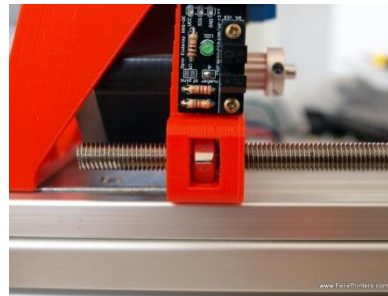

Slide in the M8 nut into the side of the small z-axis carrier part.

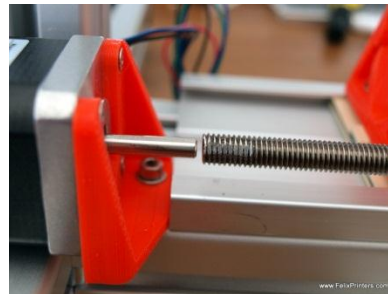

Guide the spindle through the z-axis spindle mount through M8 nut just inserted in the z-axis carrier. Turn the spindle until the bottom of the spindle has a distance of 2mm from the top of the z-axis motor axis.

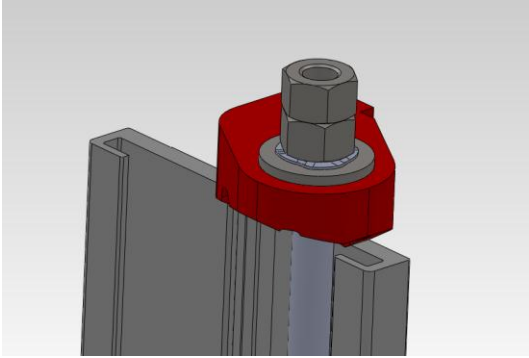

Fix the spindle with two M8 nuts. Turn the first nut by hand against the bearing. Put a curved washer underneath the nuts.

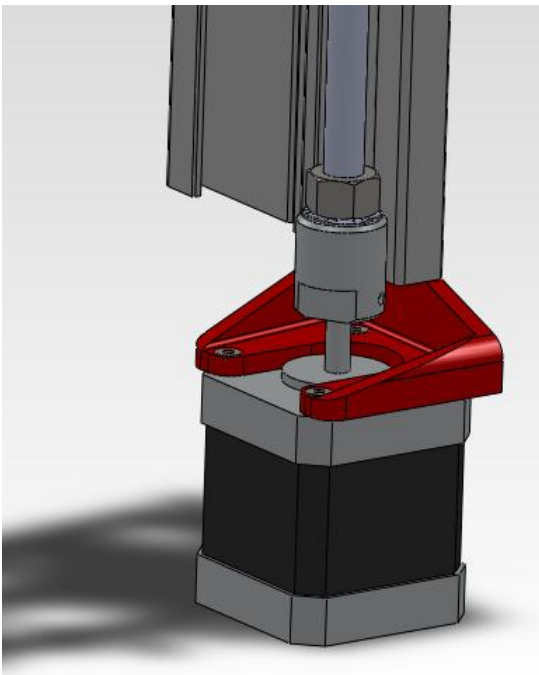

Screw the coupling on the spindle at the bottom end. Don't forget to use a curved washer. Fix the coupling by holding it and turning the m8 bolt against it. Don't fix it very tightly.

The curved washer is to compensate for an uneven surface of the m8 nut. If you mount it too the curved washer will not help anymore.

Put the printer upright and fix the m3 setscrew in the coupling very gently on the motor-axis. You should still be able to lift the coupling of the motor axis. Try to turn the coupling with your hands gently and see if the motor is not wobbling when rotating the coupling.

If it is wobbling try to fiddle the motor mount a little bit and turn again. Repeat this until the motor is not wobbling anymore. Now fix the setscrew of the the coupling.

You are now done with the z-axis.

## 7 Module 3: The Extruder (time: 30-90 min.)

Collect the following tools

- Allen key set
- Large file

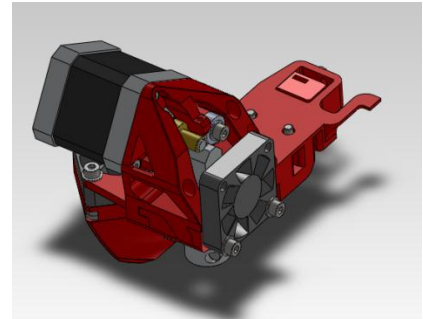

BOM Extruder	
Part description	Amount
Extru_base_v9_F1_5	1
Extru_base_pt2_v5_F1_5	1
Extru_base_pt4_F1_5	1
Extru_arm_v4_F_1_5	1
y-stage bracket pt4_v4	1
Extru_airduct_v2	1
motor nema 17	1
Fan 40x40x10mm	2
small bearing	1
extruder_insert_piece	1

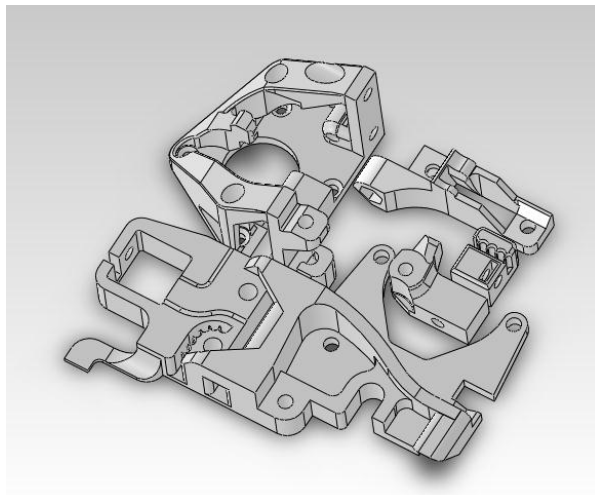

We need the above printed parts

We will create small sub assemblies and then join them together

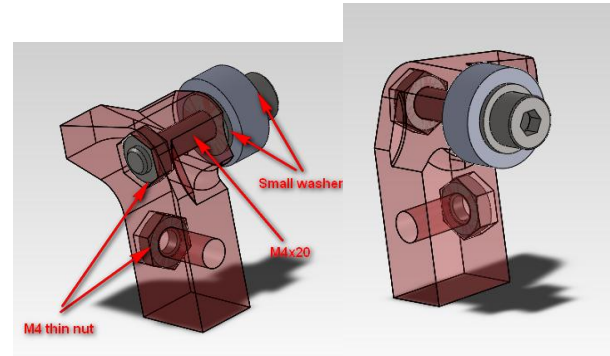

Mount parts onto the extruder arm:

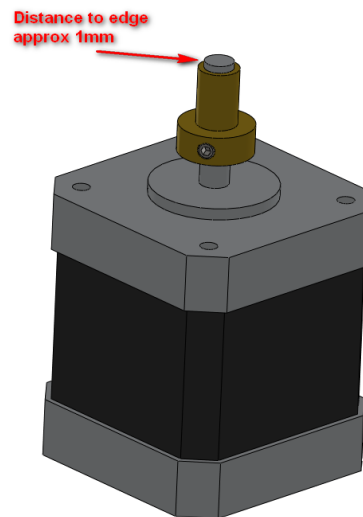

Mount the extruder wheel onto the motor. Make sure you get the little set-screw from the bag of the extruder wheel. The set-screw should not stick out.

NOTE 1: sometimes the tolerances of the extruder wheel are tight. It is very difficult to get it on the motor-axle. If that is the case, try to drill out the hole with a 5mm drill.

NOTE 2: The set-screw of the extruder wheel should maximally stick out 0.5mm. File it shorter if required, otherwise it could touch and grind the surrounding plastic parts.



# FELIXPrinters

Make sure motor cables are orientated here

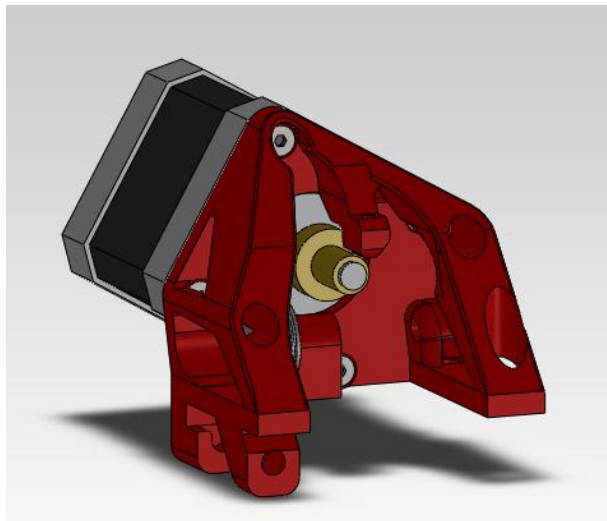
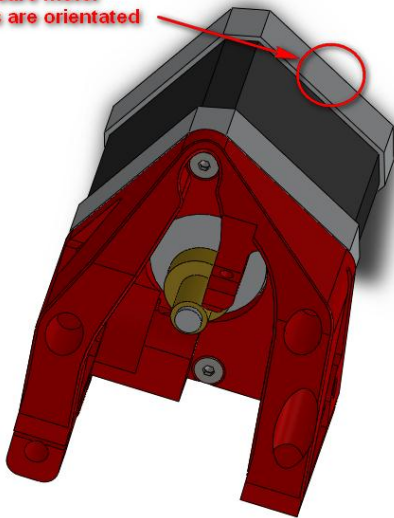

Mount the motor onto the extruder part displayed above

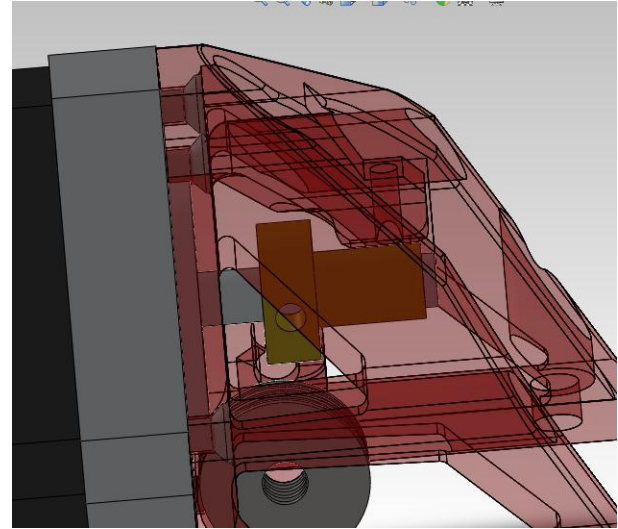

Mount motor onto displayed extruder part. make sure the extruder wheel is close to the edge of the motor axle.



# FELIXPrinters

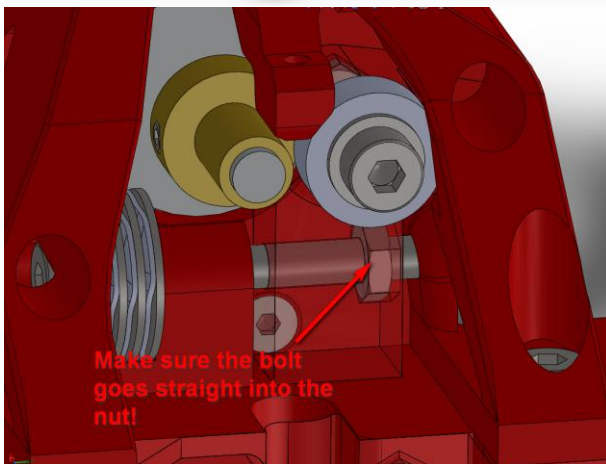
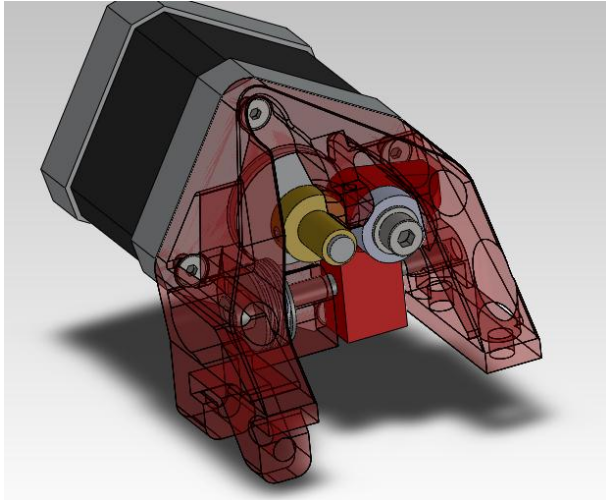

Mount the extruder arm onto the just mounted parts. An m4x40 bolt is required. Use 4 large washers and 3 curved washer as shown in the picture above. NOTE: Make sure the bolt goes straight into the nut!

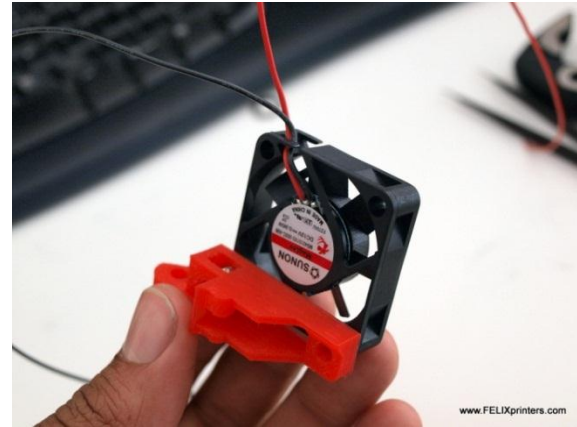
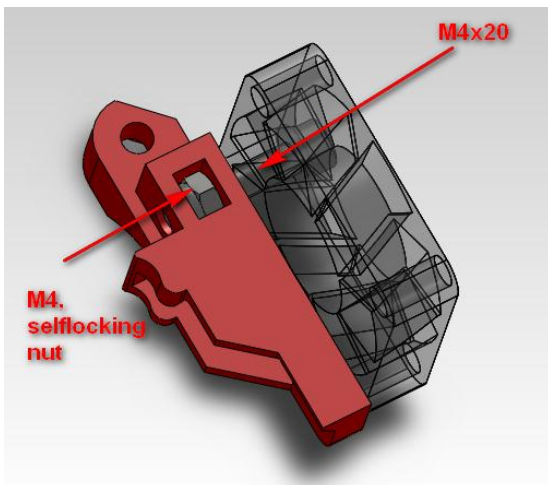

Watch the orientation of the fan. Make sure the wires match and also the orientation of the sticker on the fan. The fan blows out air at the side of the sticker.

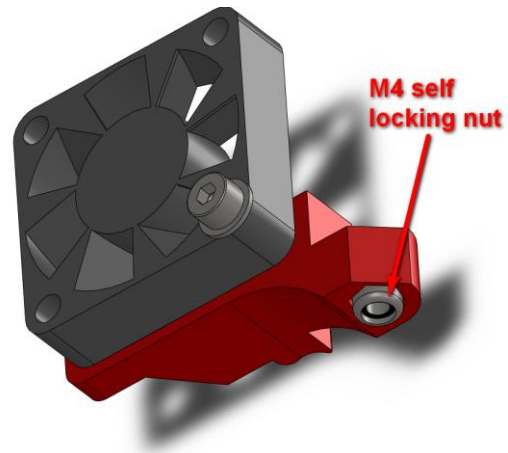

Mount the parts to the hinged door part.

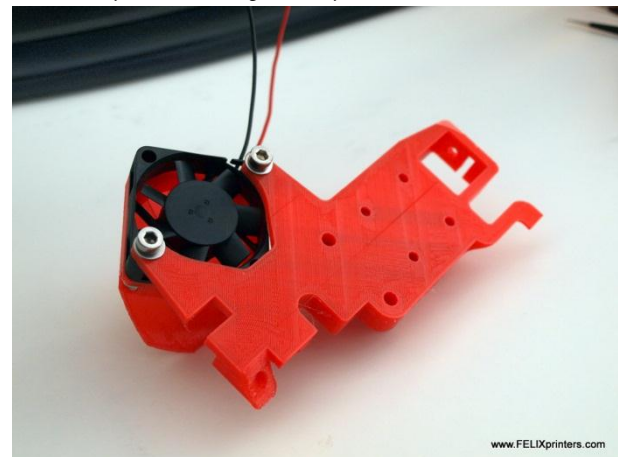

Mount the fan and airduct with m4x20 bolts onto the extruder base. Use m4 selflocking nuts and also use washers. The bolts don't have to go all the way through the self locking part of the nut. NOTE: watch the orientation of the wires and also make sure the sticker of the fan is facing downwards.

# FELIXPrinters

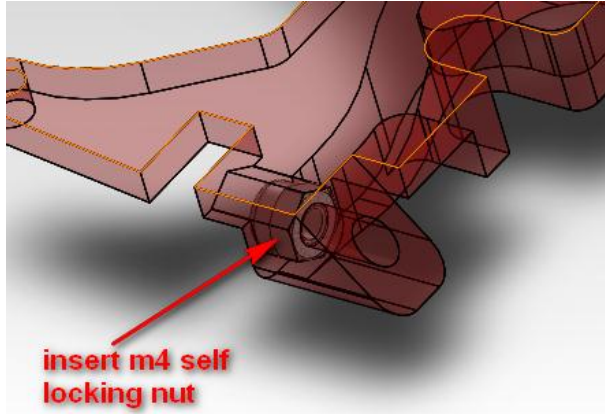

Move motor subassembly to base part.

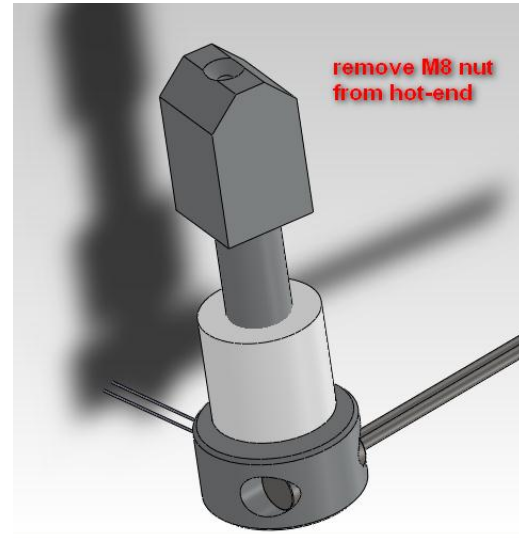
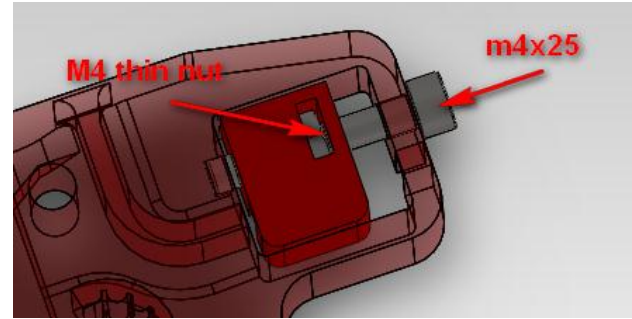
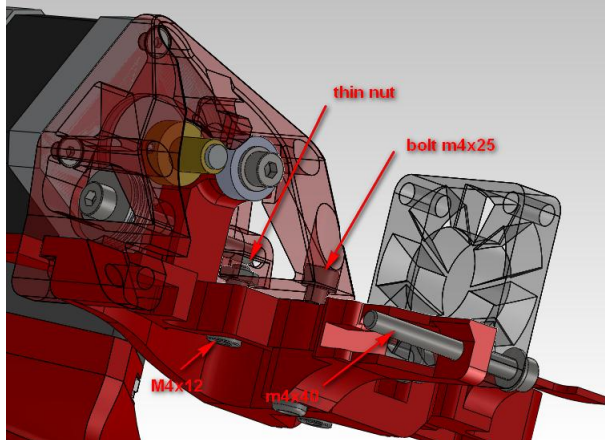
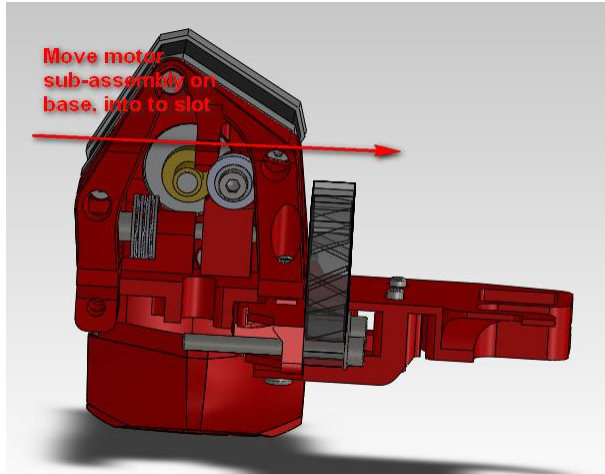

If there is an M8 nut present on the top part from hot-end, it needs to be removed. Fixate peek middle part with pliers and unscrew top part with a 12mm wrench.

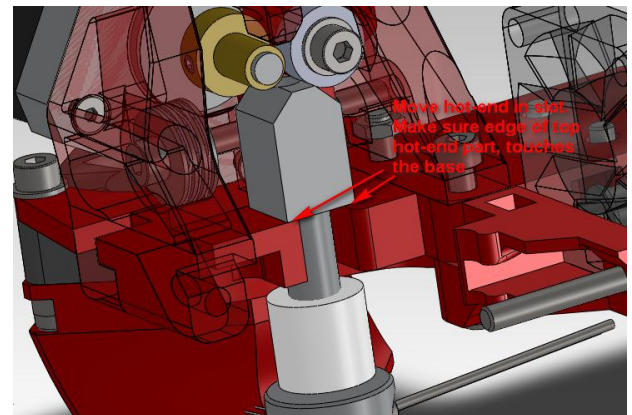



# FELIXPrinters

---

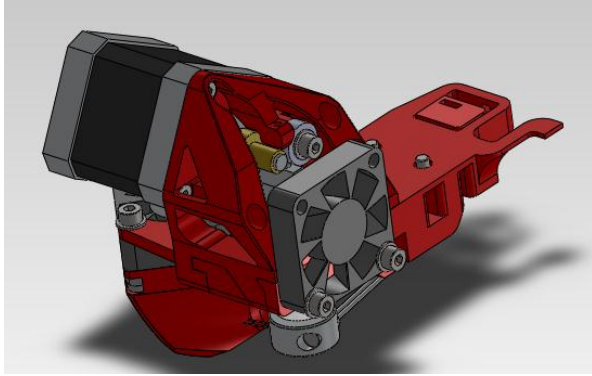

Close the hinge door and screw in an m4x40 bolt to fix the door.

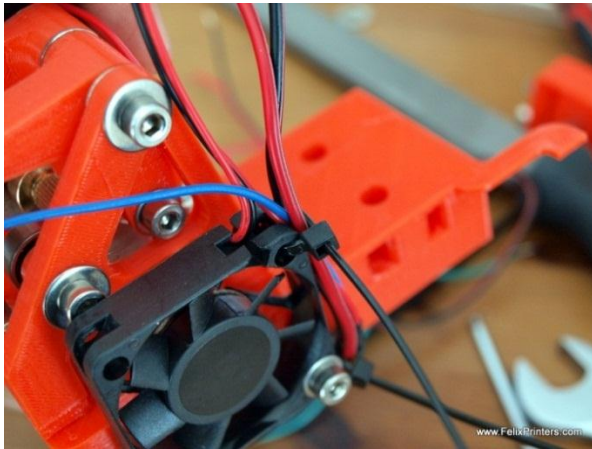

Finally guide the cables of the hot-end next the the fan. Use the hole of the fan and a cable-tie to fix the hot-end cable. (this is a picture of the old extruder version)

Congratulations you've finished the extruder module!



## 8 Module 3: The X-axis (time: 30-60 min.)

**Note:** Don't waste any belt. There is only one long belt in the kit, which must be divided in such a way that it is usable for the x and y-axis.

BOM x-axis	
Part description	Amount
x-stage-motor-bracket_v5	1
x-axis belt mount_v3	1
Igus GmbH_NS-01-40 - rail	1
Igus GmbH_NW-02-40 - cart	1
pulley_motor_HTD	1
motor nema 17	1
bearing 624	1
optosensor	1

**IMPORTANT:** The top of the plastic part should touch the top aluminum beam. Tighten this nut firmly, because it is not possible to move or tighten it in an easy way later.

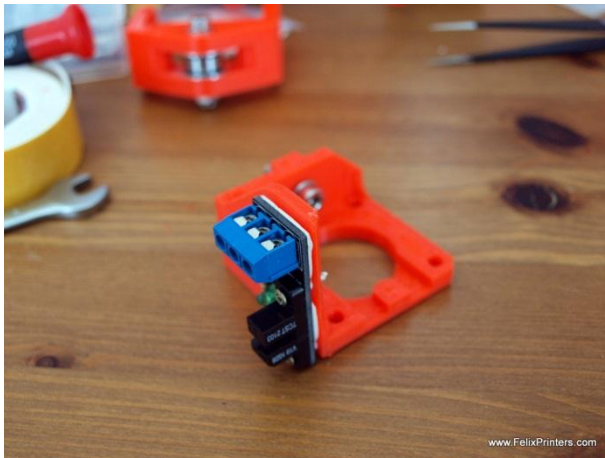

Get the x-axis motor bracket, mount the optosensor don't forget to put the double sided tape underneath. Then mount with the bronze screws.

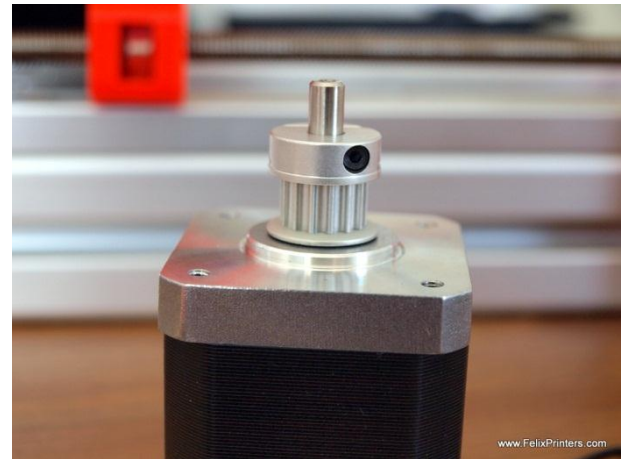

Take a motor and mount the pulley upside down. The distance between the bottom of the pulley and the face of the motor should be approx 0.5mm, this can be adjusted later on.

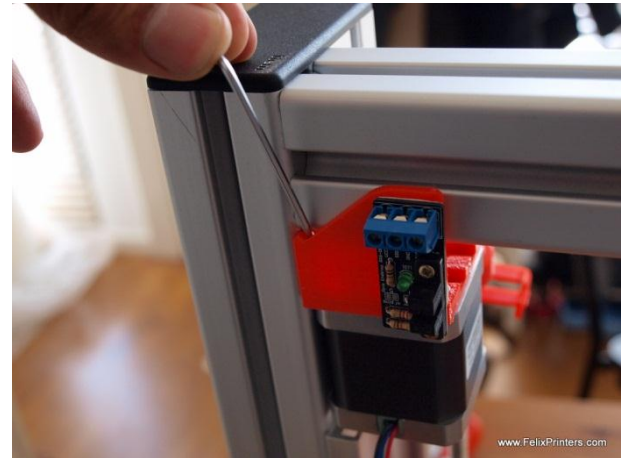

Mount it to the frame by inserting a t-slot nut and then mount the bracket with a small washer and a M4x16 bolt.

# FELIXPrinters



Mount the motor to the x-axis motor bracket with the m3x8 countersunk bolts. The bolts can be accessed through special holes and edges made.

**TIP: put the m3x8 csk bolts in place with the tweezers supplied in the kit!!**

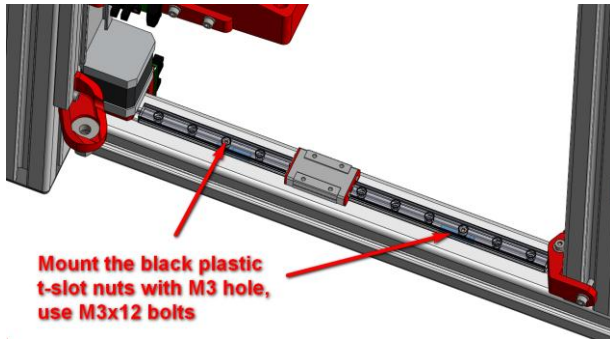

Mount the linear bearing with corresponding use the black plastic t-slot nuts with m3 hole in them. Mount the rail with m3x12 bolts

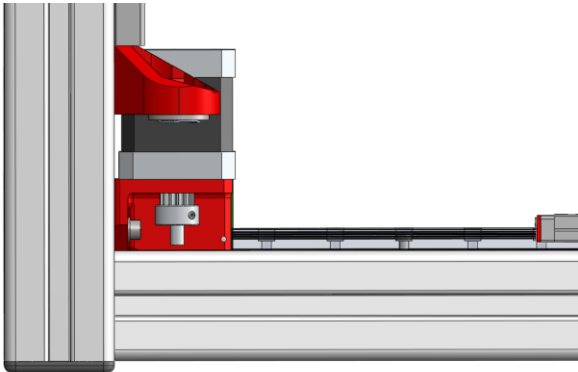

Fix the x-axis rail. The position of the rail should match the picture above.

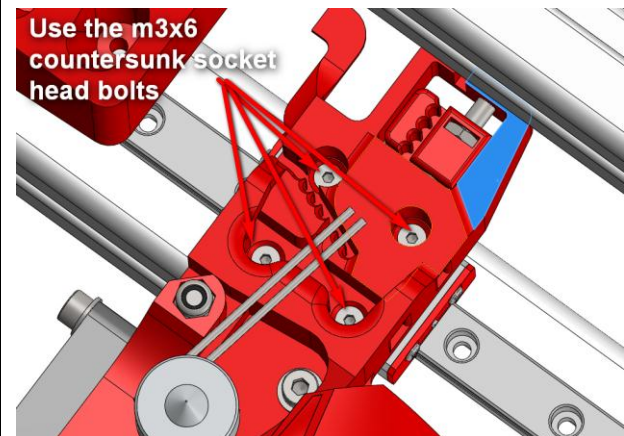
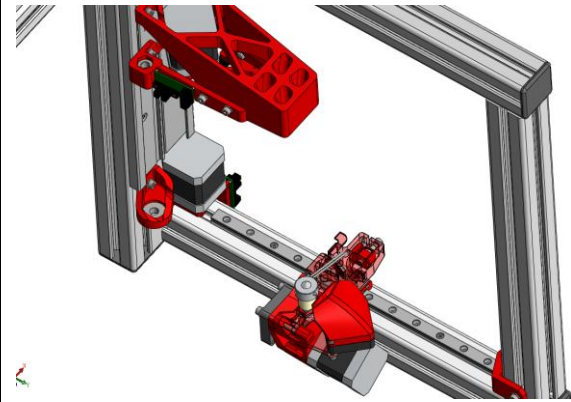

Mount the extruder assembly on the cart of the x-rail. Use M3x6 countersunk socket head bolts.

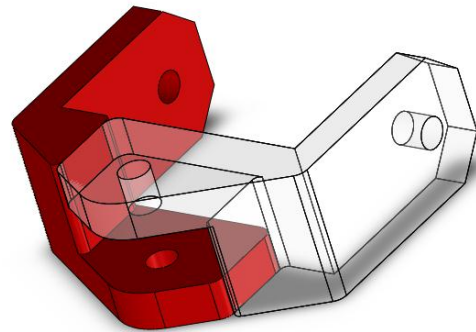

Take the 2 printed x-axis belt mount parts.



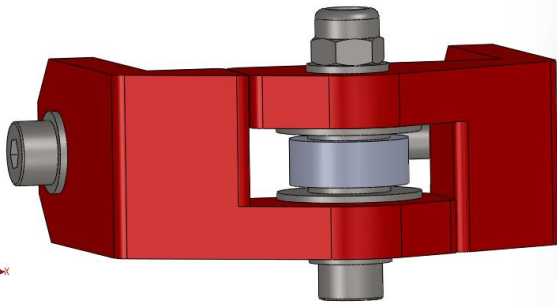

Mount the bearing onto the two parts. From bottom to top:  
M4x25 bolt, small washer, plastic part, large washer, small washer,  
bearing, small washer, large washer, plastic part, small washer, self locking  
nut.



It's now time to mount the *x-axis belt mount* parts onto the frame.  
Before doing this cut the belt at one point and guide the end over  
the bearing as indicated above. (The part displayed in the picture  
above is from an older revision, but instruction is similar.)



Put the t-slot nuts to mount the x-axis belt mount.

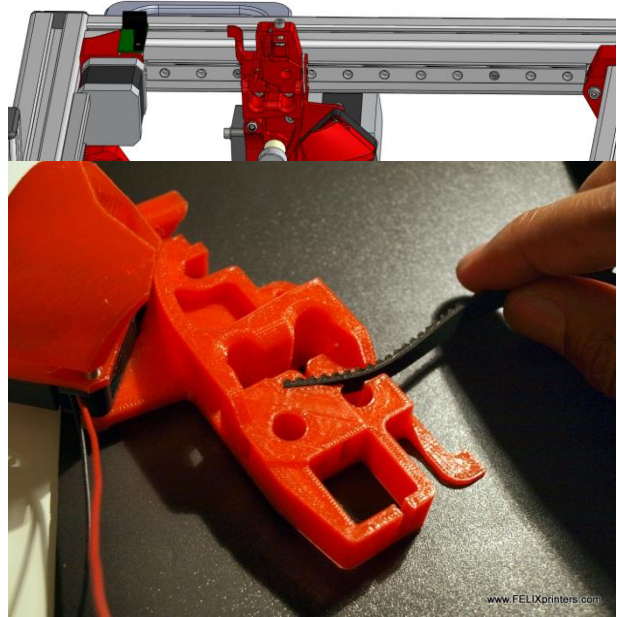

Now the belt has to be guided over the motor-pulley and then to  
the extruder base.

The extruder should already be assembled onto the carriage. The  
picture above is pure to illustrate how to mount the belt onto the  
carriage. Push the belt fully into teathed slot of the extruder  
carriage.

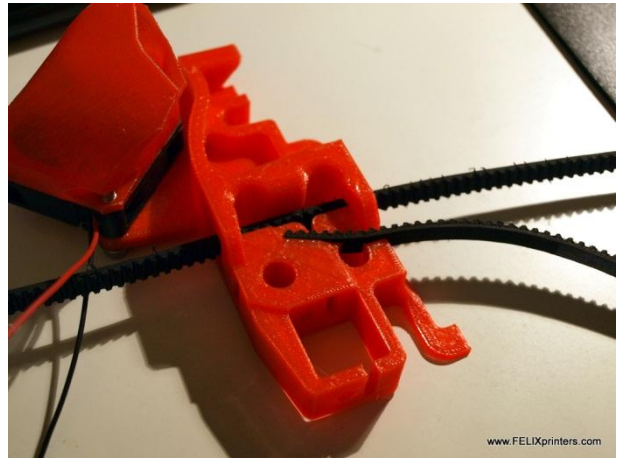

Guide the belt through the hole of the extruder base

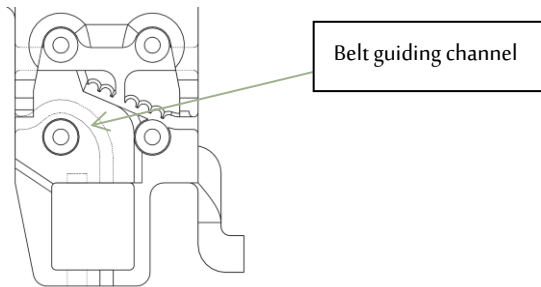

Guide it over the motor-pulley back to the extruder base

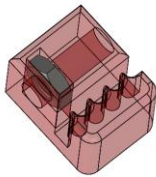

Put a M4 thin nut in the slot of the y-stage bracket pt4\_v4 part.

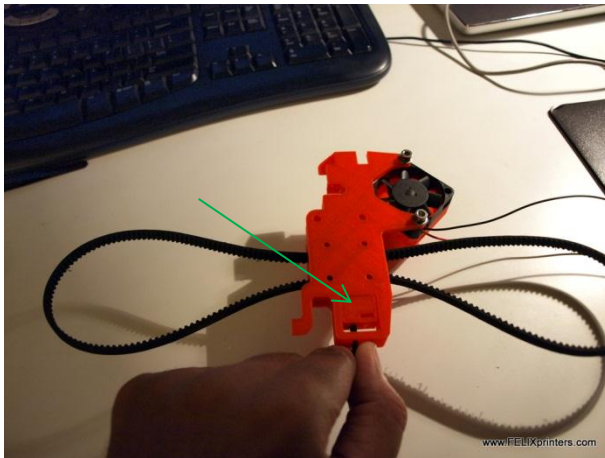

When the belt is guided over the pulley and bearing, pull on it as shown on the picture above. Then when there is tension put the

small part on the belt. Put it as close as possible to the base. This way enough tension can be exerted on the belt when the tensioning system is used.

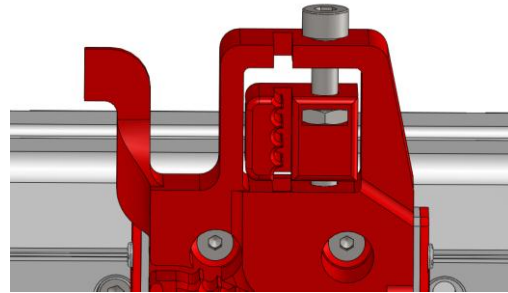

When the small bracket is mounted, fix it with a M4x25 bolt. Before putting more tension on the belt, make sure the belt is aligned well. It should not rub on the guiding washers besides the bearing. Also make sure the belt-mount is fixed on the frame.

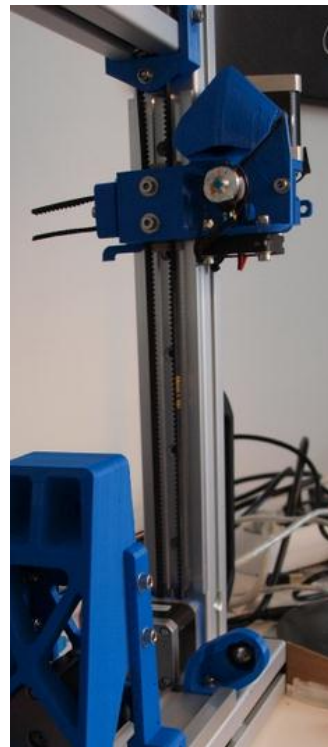

It finally should look like the picture above. This however is a picture from an older revision.

Cut off the remaining piece of belt. Only 2cm should stick out of the end of the extruder base. **Don't waste any belt. There is only one long belt in the kit, which must be divided in such a way that it is usable for the x and y-axis.**

You have now finished the x-axis!

## 9 Module 5: Table (time: 1-2 hours)

### Important notes:

Work carefully; this will benefit the print quality. Make sure that you don't warp the surface of the table by exerting too much force /weight on the table

BOM table	
Part description	Amount
table_2mm	1
Resistor 4.7 Ohm - heated bed	4
Pre-crimped cables 2 threads	1
Piece of wire 2m	1
Silicone kit heat resistant	1
Cooling paste	1

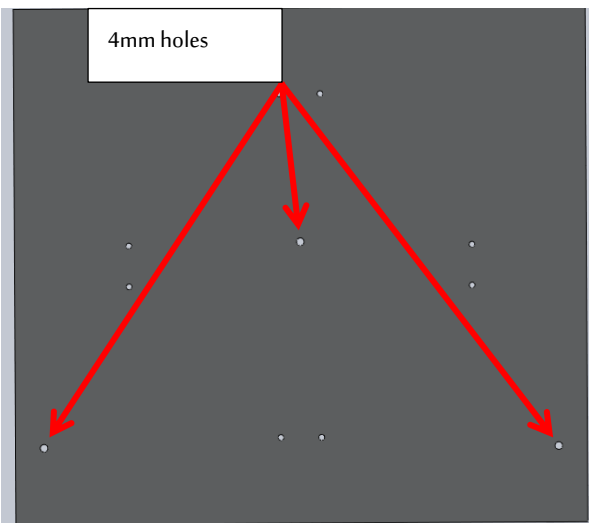

Take the plate. Note that there are three, 4mm holes which are reserved for the M4x30 countersunk bolts. Further more there are eight 3mm holes which are reserved for the M3x8 countersunk bolts. These are needed to mount the power resistors.

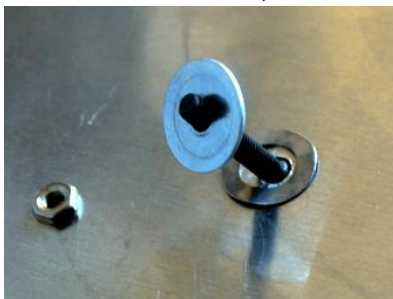

It is time to mount the M4x30 countersunk bolts. The order: bolt, crinkled washer, large M4 washer, M4 nut.

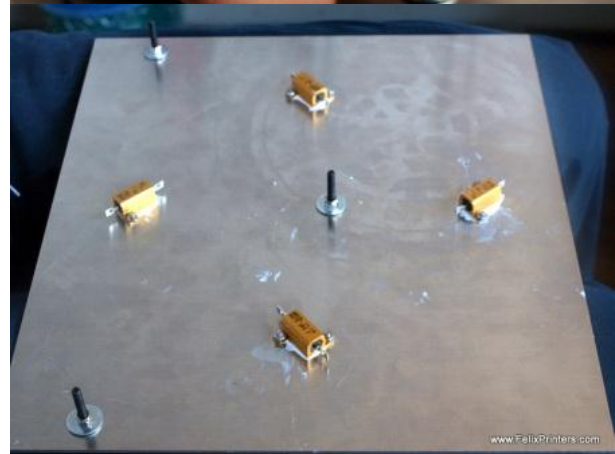

The bed uses 4.7Ohm resistors. When all the resistors are drilled out and they can be placed loosely on the M3 bolts. Put some cooling paste on the flat side of the resistors; mount it as shown on the table.

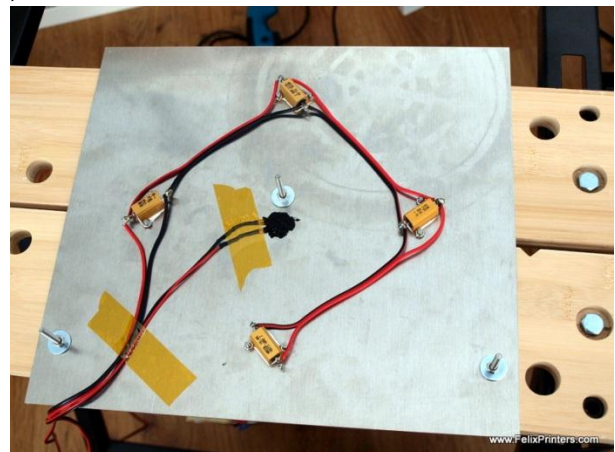



Now it is time to glue the thermistor on the table and solder the wires.

Like displayed above

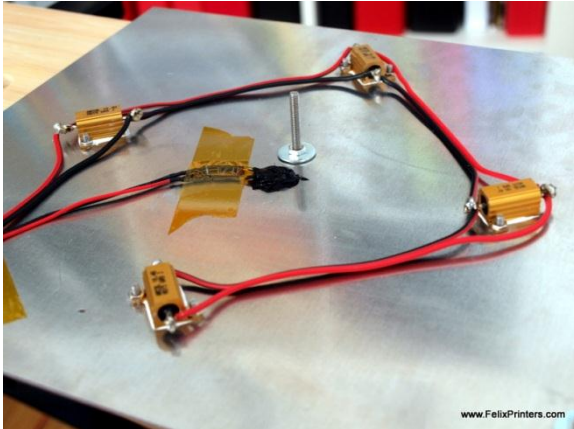

Start by soldering the wires onto the heat resistors:

- From the double wire cut 3 equal pieces of 200 mm. The rest of the wire will go from the bed to the electronics. **Don't waste too many, because the rest of the wire goes from the table to the electronics.**
- Strip all wire ends, twist the stripped end and guide it through the holes of the resistors.

Steps for thermistor:

- Glue the thermistor head approx. in the middle of the bed with heat resistant silicone kit or other heat resistant type of glue.
- After glue-ing put some kapton tape on the wires to make sure the thermistor stays in place.
- Let it dry.

## 10 Module 6: Y-axis (time: 10-30 min.)

### Required tools for this module

- Allen key set.

BOM y-axis	
Part description	Amount
y-stage bracket pt1_v6_F1_5	1
y-stage bracket pt2_v5_F1_5	1
y-stage bracket pt4_v4	1
20x10_aluminum profile + protective cap	1
t_slot_nut_5	1
Hiwin linear ball bearing set	2
t_slot_nut_5_M3	2
t_slot_nut_8_M3	3
ISO 10642 - M3 x 6 --- 5N - CSK	5
Hexagon socket head cap screw DIN 912 - M3 x 8	2
Hexagon socket head cap screw DIN 912 - M3 x 12	4
Hexagon socket head cap screw DIN 912 - M3 x 16	10
Prevailing torque type hexagon nut ISO 7040 - M3	6
Washer ISO 7089 - M3	6

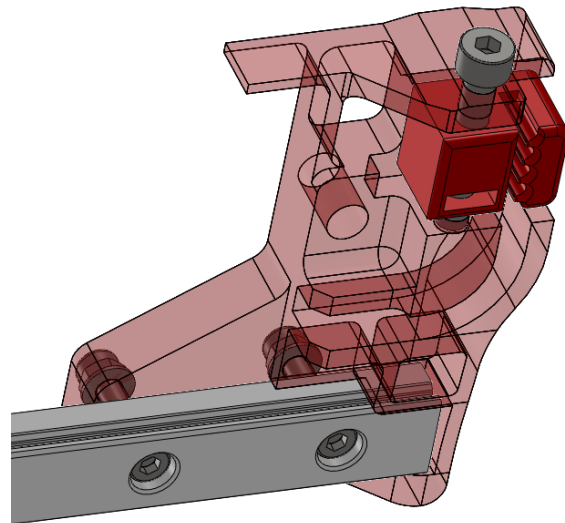
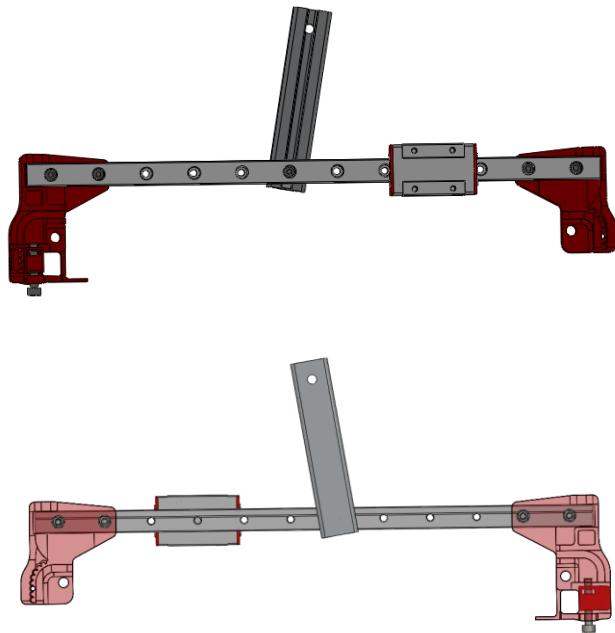

Mount both brackets onto rail with m4x16 bolts and the m3 self locking nuts. Don't forget to place the washers

# FELIXPrinters

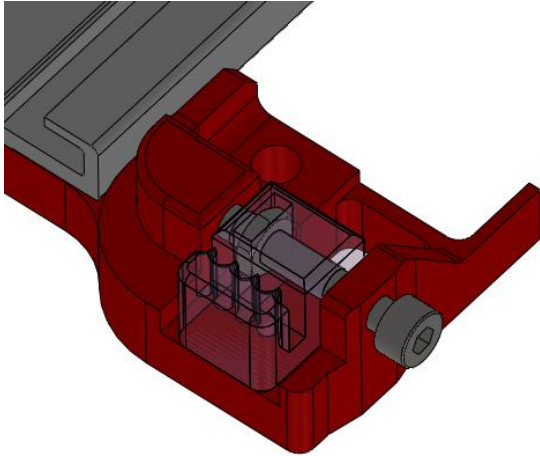

Mount the small *y-stage bracket pt4\_v4* onto the *y-stage bracket pt2\_v5\_F1\_5*. Use a m4x25 bolt and a m4 nut. This small part is needed to tension the belt later on.



Get the small aluminum beam, first put the plastic cap on it, next to the drilled hole. This can be done with a hammer.



Slide in the small t-slot nut on the other side, and mount this beam onto one of the middle 2 holes of the y-axis rail with a M3x8 bolt.

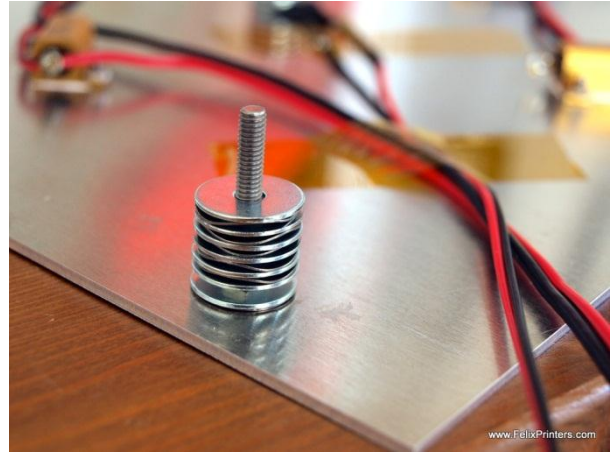

Now it is time to connect the table assembly with the y-axis assembly.

- Take the table. Put it with the face on a flat scratch free surface.
- Put washers and curved rings on the m4x30 countersunk bolts. It is important to match the amount of washers on the picture above.
- On the 3 M4 countersunk bolts of the table make sure that on top of the already placed rings from the previous module, there are 6 large M4 washers and 5 curved rings in total. See the illustration above.

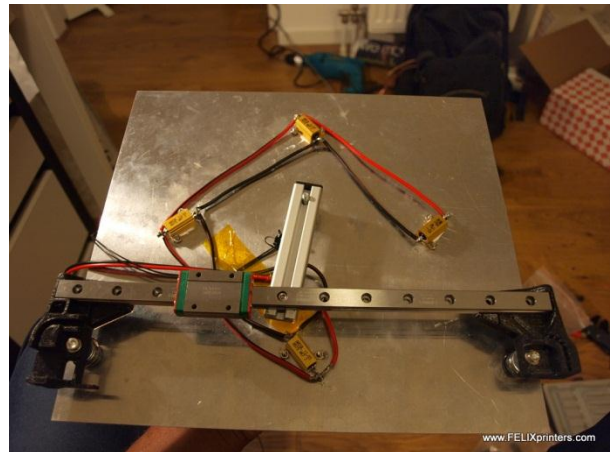

Now place the y-axis onto the table. When it doesn't directly fit, there is no need to file any parts. The three bolts can be slightly re-oriented. This can be done to exert a little sideways force on the bolt. When it still doesn't fit, you could try to adjust the position of the small aluminum beam.



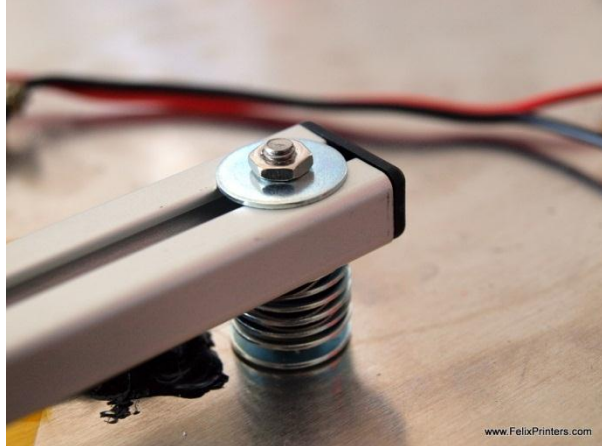
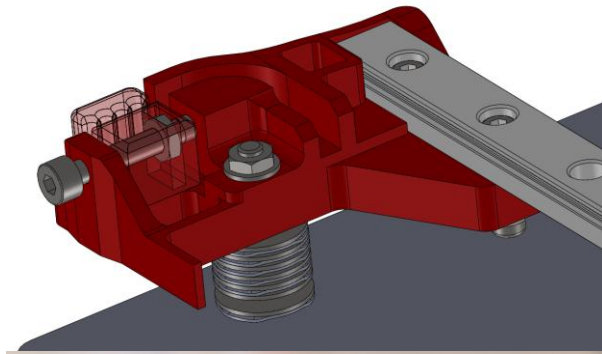

After placement mount table bolts with a normal M4 nut. Use a small washer underneath the m4 nuts at the plastic parts. Use a large washer for the bolt at the small aluminum beam.

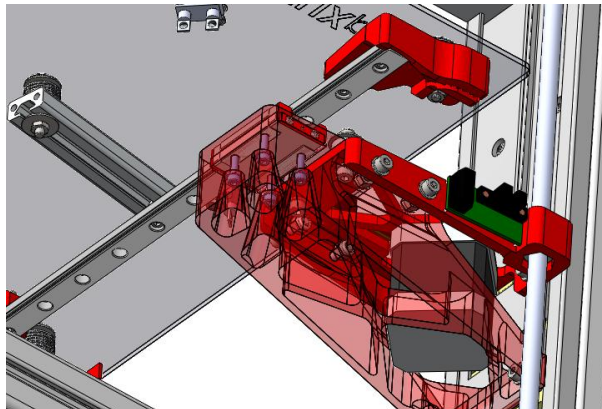

Mount the y-axis cart on the z-axis part with four M3x16 bolts with the m3 washers.



Now it is time to put the left over belt from the x-axis onto the y-axis. Take the belt and cut it off straight.

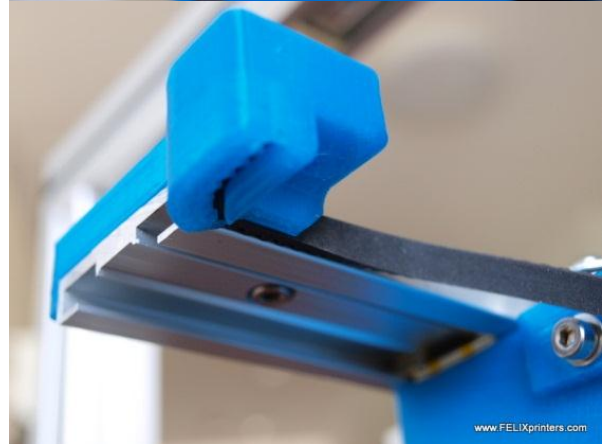
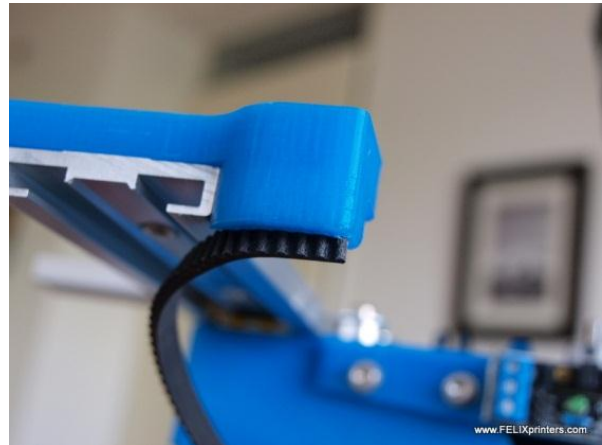

Push the belt inside the bracket. Let the belt make contact with as much teeth of the bracket as possible. Also push it as far as possible, use a small allen key for that. If you have misplaced the belt or you want to remove it, on top of the bracket is a small hole which can be used to push out the belt with a small allen key.

# FELIXPrinters

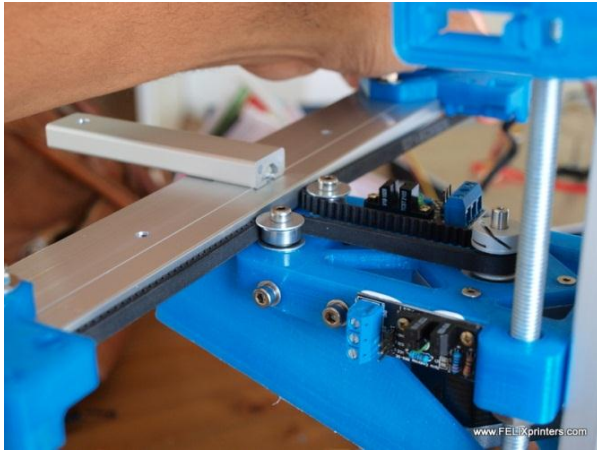

Guide the belt over the pulley and 2 bearings as indicated above.

NOTE 1: The pictures are from the Felix 1.0, but the procedure is the same.

**NOTE 2: If you are doing this module before assembling the x-axis module, do not waste unnecessary pieces of belt, because it is needed for the X-axis!!**

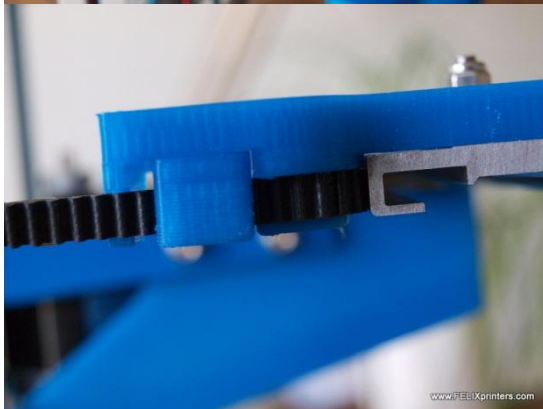
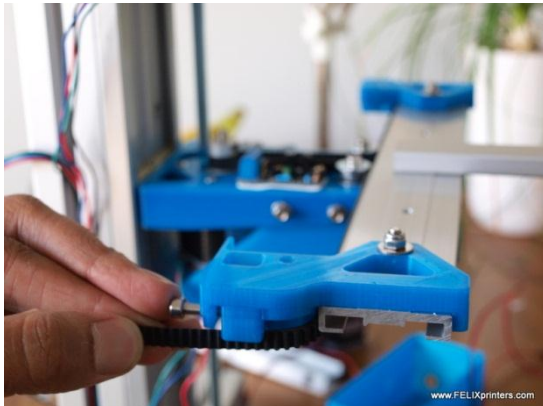

Push the belt into the small printed clamp, while at the same time tensioning the belt by hand. Important is that the small clamp is touching the right edge of the bigger part as shown in the picture above.

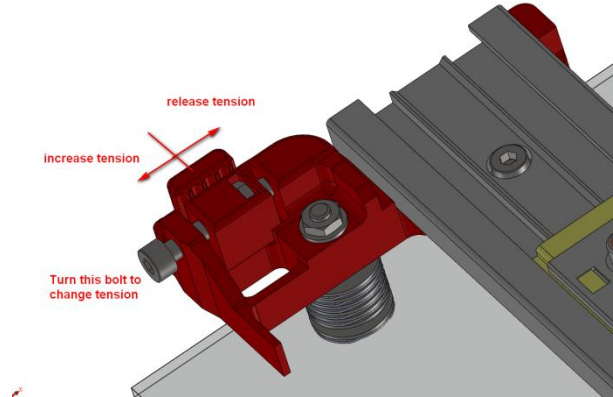

Next step is to tension the belt by turning the tensioning bolt. See picture above. The belt should be tensioned when the distance between the parts is approx. 1 to 2 mm.



Check if you applied enough tension by pushing the belt as displayed above. It should feel firm.

Congratulations, you are done with this module and the mechanics of the printer and it should look like this:

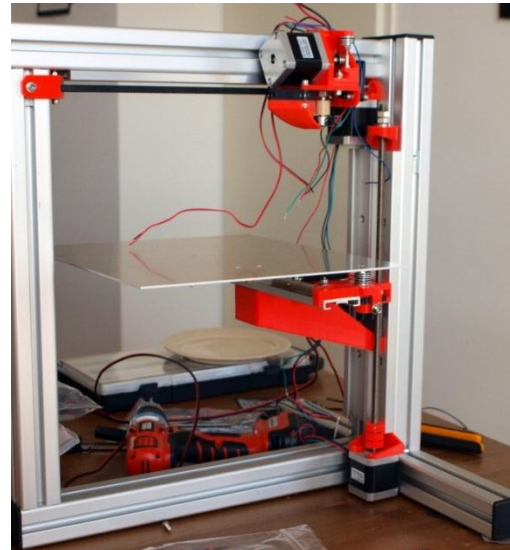

## 11 Module 7: Electronics (time: 2-4 hrs.)

The goal of this module is to install all electric wires and to neatly put them away in the frame.

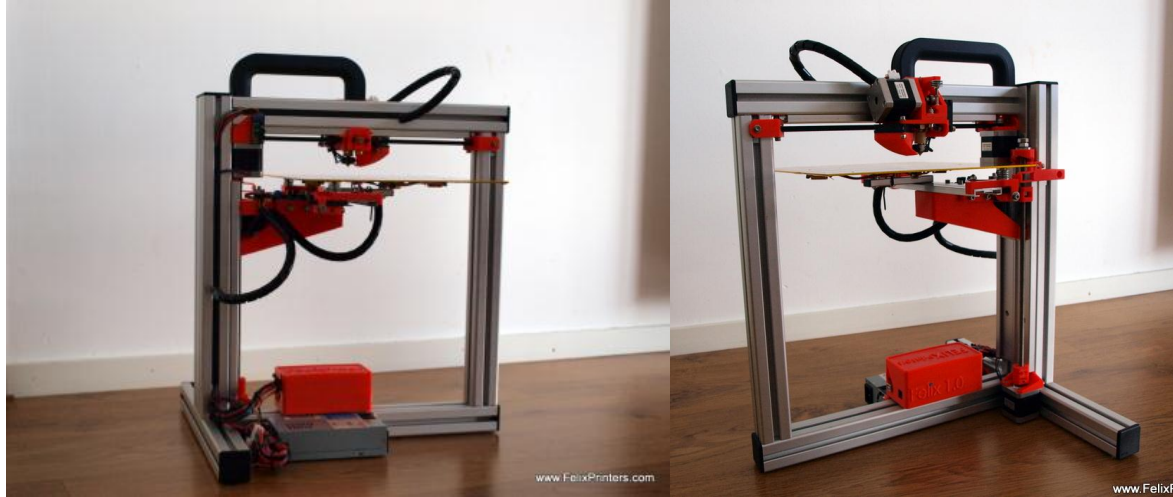

The required tools for this module are:

- Soldering iron
- Solder
- Flux
- Allen key
- 7mm wrench

# FELIXPrinters

To make the printer work properly the schematics below must be matched.

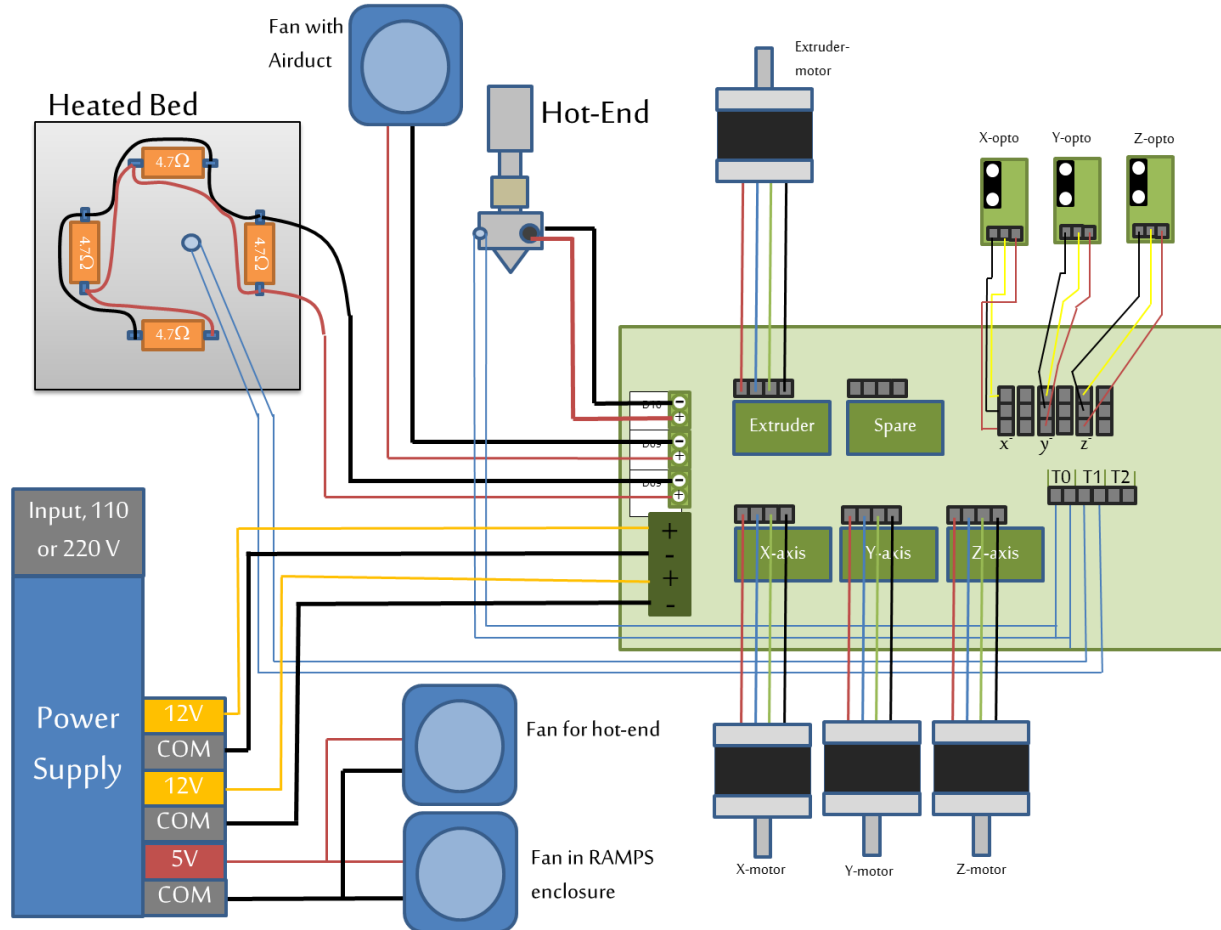

The description below will guide you step by step to match the schematics above.

**NOTE:** It is important that the cables are placed as neatly as possible. Placing the wires in a messy way, can lead to EMC problems, which than can lead to unreliable printing. Also the board could become sensitive from outside influences, for instance when a lamp is switched on or off the electronics could stop working until you reset it again.

**After building several printers, we found that the best way to neatly do the cabling is to work from the electronics board to the components.**

**We use the following workflow:**

1. Mount the power supply to the frame
2. Label all cables
3. Place as much cables as possible to the electronics board.
4. Connect the opto sensors
5. Connect the motor wires
6. Connect the y-axis table wires to the board.
7. Connect the rest of the wires
8. Clean it up and place the wires into the frame and mount on wire loops cable spiral.

This section will walk you through the above steps



## 11.1 Mount the powersupply.

BOM Electronics	
Part description	Amount
electronics_case_v2_ramps	1
electronics case capv1_F1_5	1
RAMPS + arduino + steppers fully assembled	1
mini-ATX-seasonic	1
Power Cable EU,USA,Australian or British	1
Fan 40x40x10mm	1
heatsinks 10*8	4
precrimped cables 4 threads	4
precrimped cables 3 threads	3
precrimped cables 2 threads	2
USB cable 1.8m	1
heatshrinks large 50 cm	1
Heatshrinks small 15 cm	4

Get the parts described in the table above.



Before starting, place some tape over the powersupply slots. When soldering it could happen that small soldering particles can fall into the slots. This can potentially damage the powersupply by creating a short circuit.

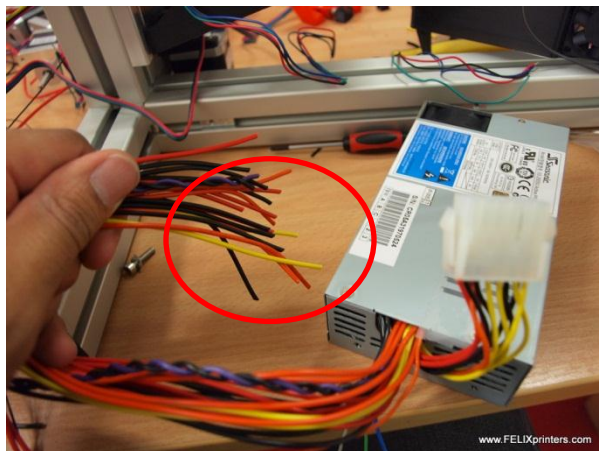

Cut the wires of the big connector

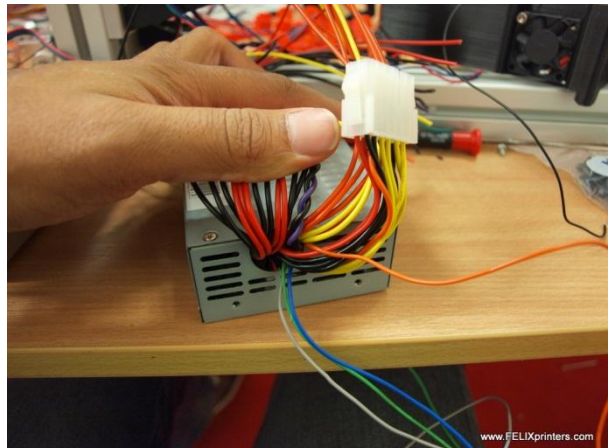

Remove the cable-tie near the powersupply and bend the cables upward.

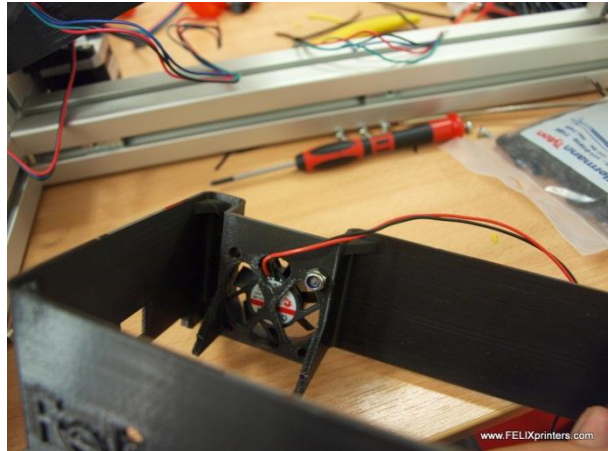

Take the big electronics casing and mount the fan onto it. Match the orientation of the fan.



Move the casing over the powersupply from the top. Guide all the cables on the inside.

# FELIXPrinters

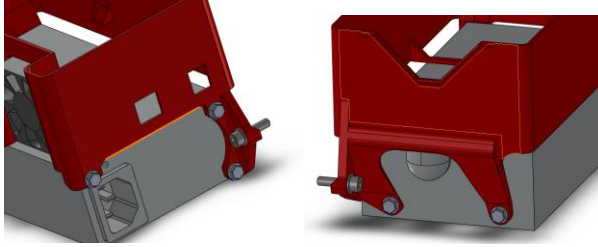

Mount the casing onto the powersupply, with 5 powersupply screws. The head on the screws may look different than on the picture, but they have a phillips head and a courser non metric thread with a length of 6mm and diameter of 3.3mm.

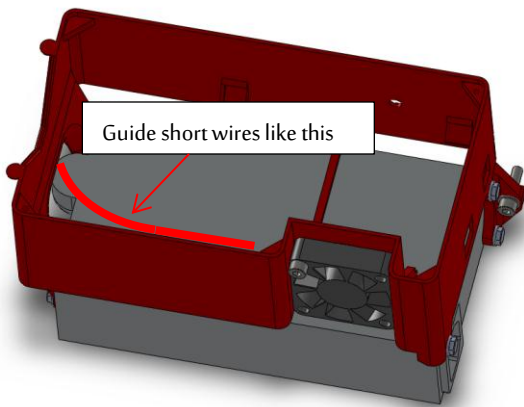
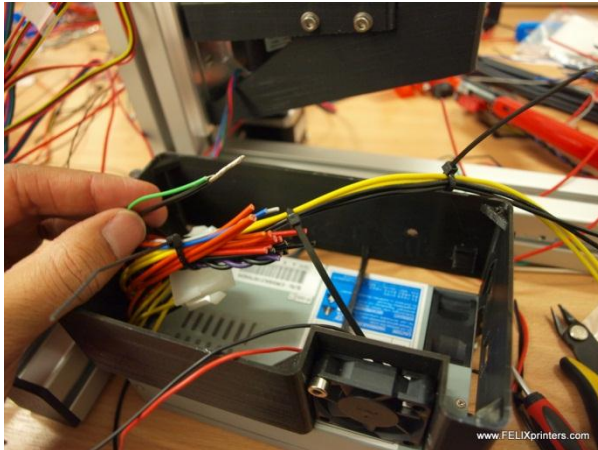

Shorten all wires **EXCEPT** the following:

- 2x yellow
- 2x black

After shortening strip a short black and the short green wire. Connect them to eachother. The green wire is the ON-switch.

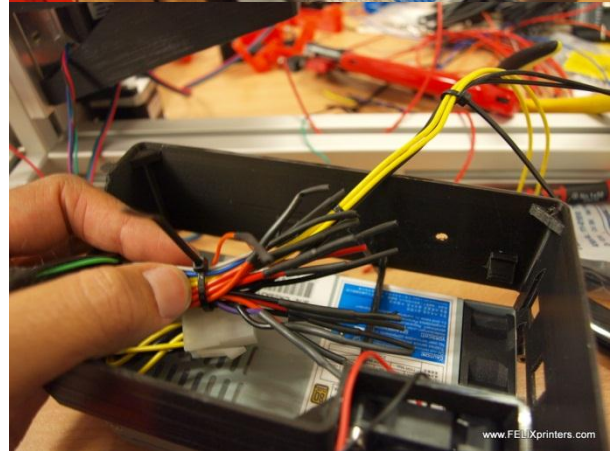
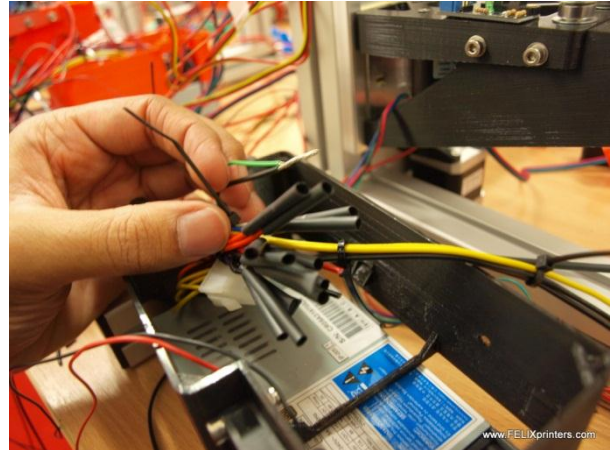

Place pieces of 2cm heat shrink on the shortened wire ends to prevent future short circuit **EXCEPT** the following:

- 1x black
- 1x dark red

**NOTE:** be careful as there are dark red and also salmon red wires.

Use a lighter or a heatgun on the heatshinks to let them shrink onto the wires.

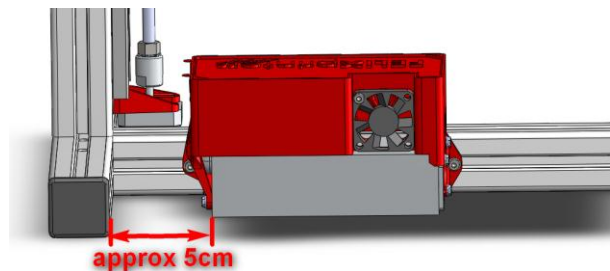

Mount the powersupply onto the frame, with m4x16 bolts including the M4 small washers.



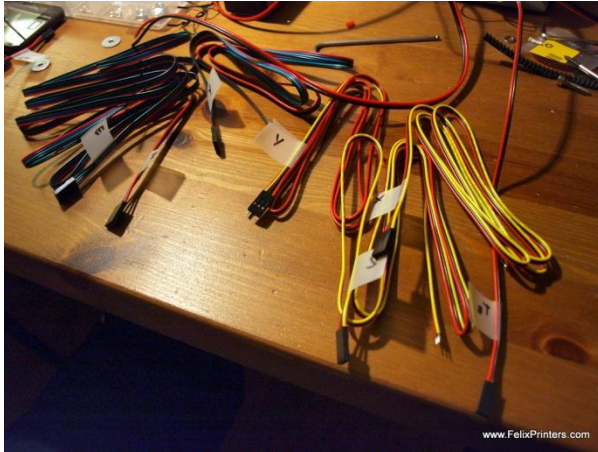

Put labels on all cables. It is very useful to label all the cables, especially when you want to remove a cable in the future for whatever reason. An easy way of labeling is to fold a piece of tape around near the connectors, and write something on it with a permanent marker.

The three wired cables are for the opto sensors, the 4 wired cables are for the motors and the 2 wired cables are for the heated bed and hot-end temperature sensors.

## 11.2 Connect all possible wires to the electronics board.

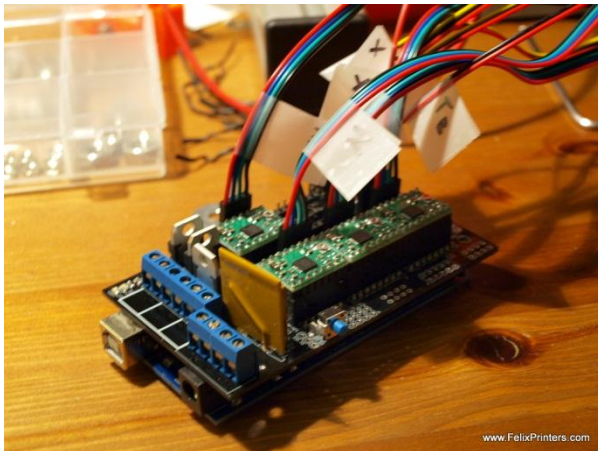

To make an as neat as possible wiring job, we work our way from the electronics board to the components. Connect all the pre-crimped cables, onto the board, the labels should correspond to the position on the board. For more details look at the schematics overview.

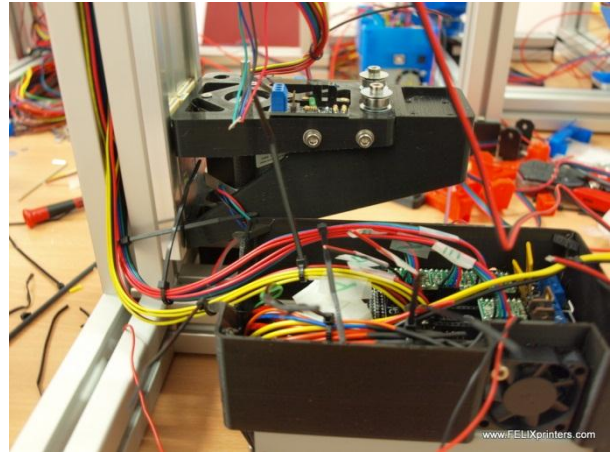

Place the ramps board in loosely in the casing. Just to get the length of the cables right. Try to group the different wire types together.

**Tip:** make good use of the cable ties supplied with the kit. They are great to form nice cable loops. Afterwards, it is easy to remove the unnecessary ones.

**Tip2:** When grouping the wire types together, combine them from top to bottom: x, y, z and extruder.

## 11.3 Connect the opto-sensors

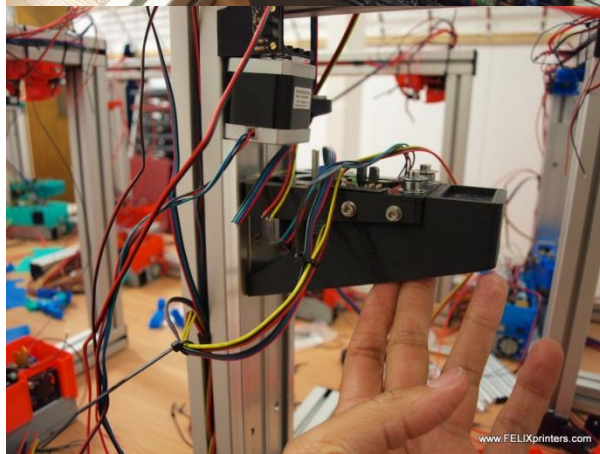
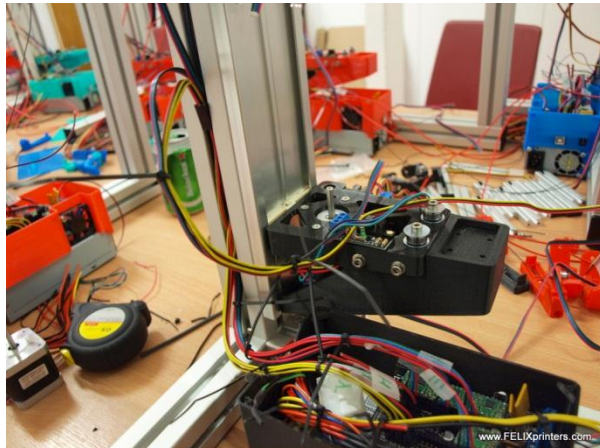

Now we are going to connect all the opto-sensor wires. Start from the ramps case. Also notice the loop on the first picture. The wires should not be in stress when you move the z-axis carrier up and down



Try to keep the wires in place on the frame by using the provided plastic frame strips. Cut off a small piece, 3cm should be enough, remove remaining sharp edges and place it onto the frame.

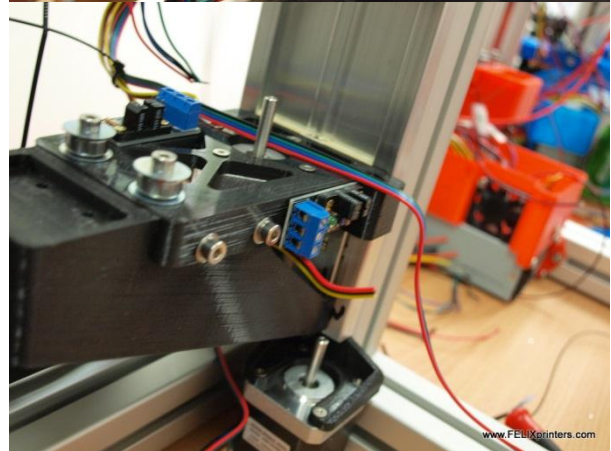
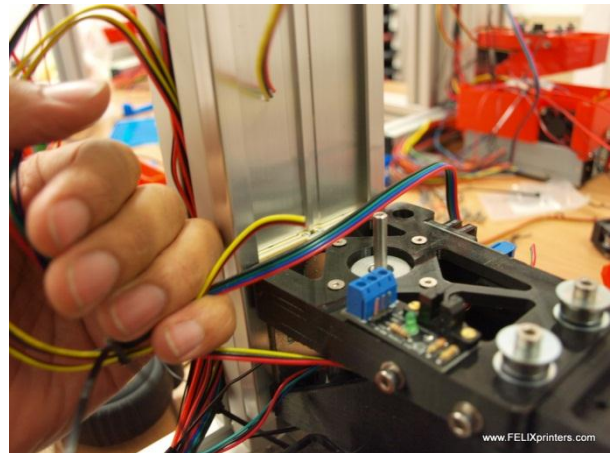

Guide the wire of the z-axis opto-sensor through the z-axis carriage to not make it interfere with any moving parts. Strip the wire ends and rub them in with flux. Then put some solder on it.

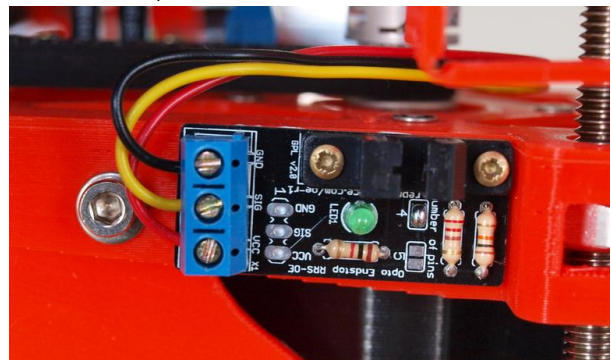



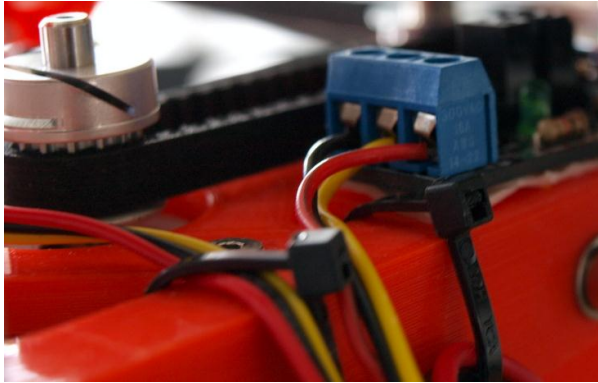

The wires of the opto sensor should look like this on the z-axis carriage.

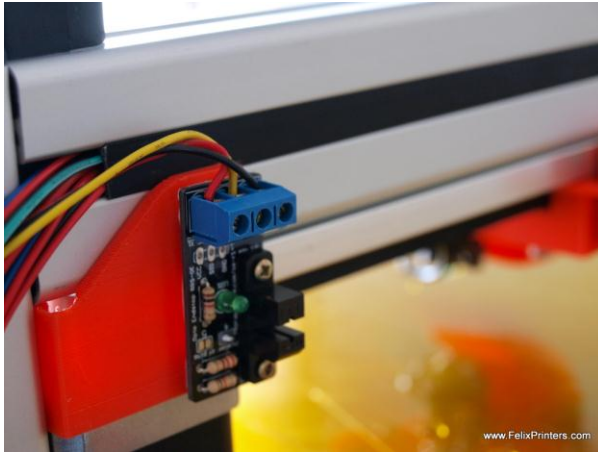

Like this on the opto switch of the x-axis.

## 11.4 Connect the motor wires

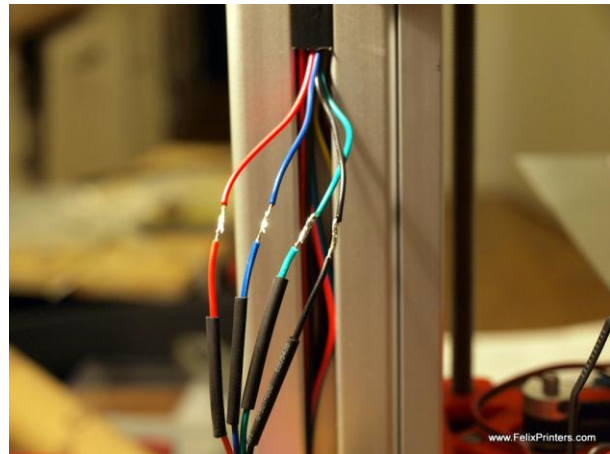
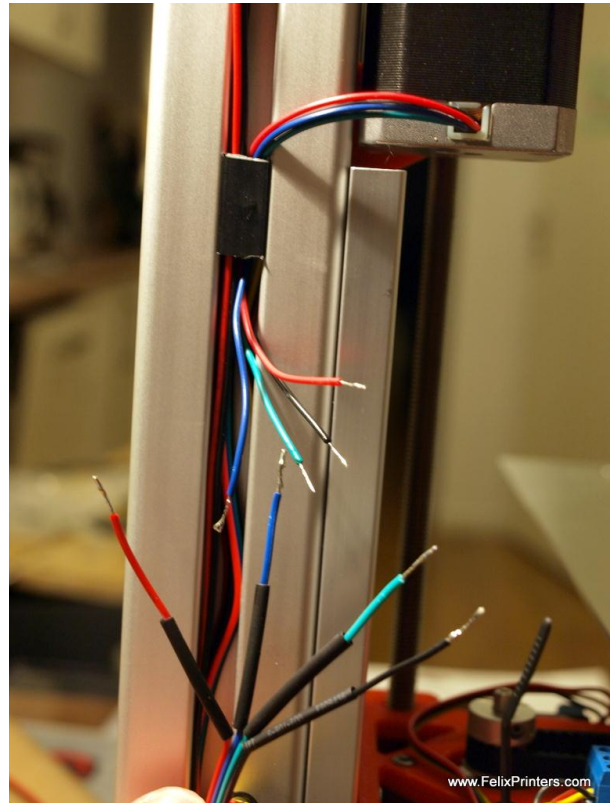

Easiest is to start with the x-axis motor:

- From both ends remove excessive pieces of cable,  
**IMPORTANT: do not throw away the cut off pieces of cable because it has to be used for later.**
- Strip the ends, recommended to use a wire stripper.
- Join the ends together, like on the picture. Don't forget to put a piece of heat shrink on each cable. Also make sure the colors match. NOTE: Recommended to join the ends together as

displayed above, do not make a knot and then solder. This will prevent the heatshinks to go over the open piece of wire.

- To nicely seal the open wires, heat the heatshrink with a heat gun or carefully with a lighter, also shortly touching the heat shrink with a soldering iron will do.

Do this for the Y and Z axes and try to follow the loops. The extruder motor however needs extra care.

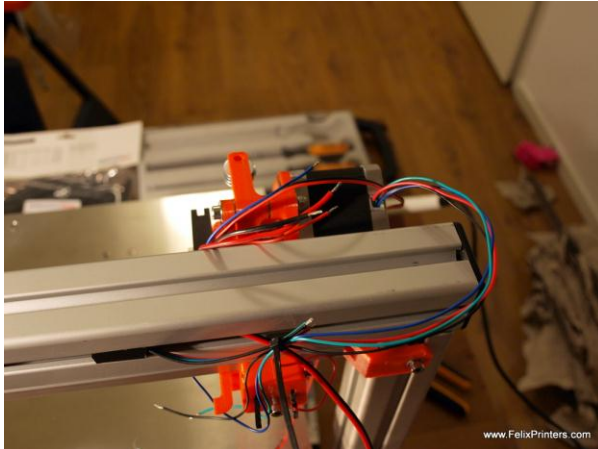
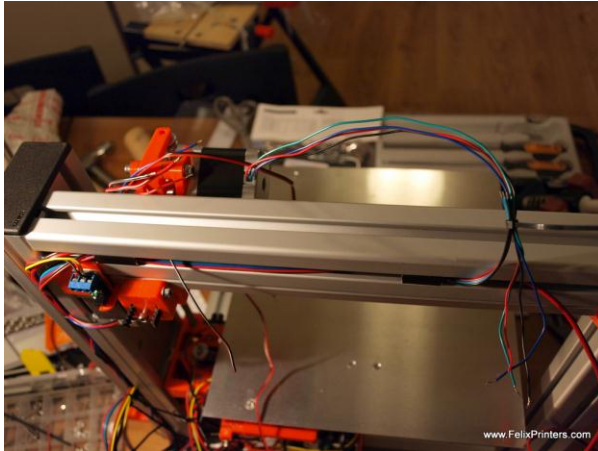

The loop must be small enough that the cable doesn't get stuck around the far edge of the top beam, when the extruder is at its end position in x-direction.

The rest of the cables which run to the extruder carriage need to follow this just created loop.

## 11.5 Connect the y-axis table wires to the board.

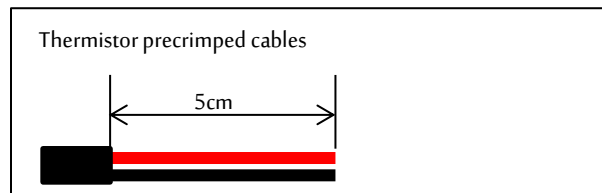

Cut the thermistor precrimped cables for the heated bed and hot-end as indicated above. Be precise, because the rest of the wires are needed to connect the fans at the extruder with the board.



The first loop goes from the heated bed to the top part of the y-axis carrier. The loop should be just big enough for the y-table to move freely. Check the loop when the axis is moved by hand from one extreme position to the other.

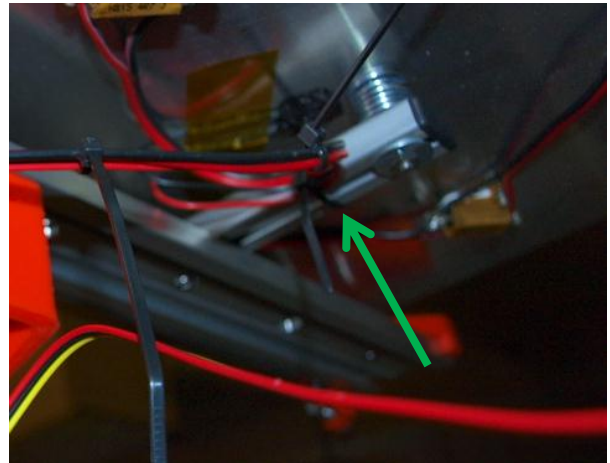

Make sure the wires are connected to the small aluminum beam by means of a cable-tie, indicated with the arrow above. It is necessary to prevent any strain on the thermistor cable.

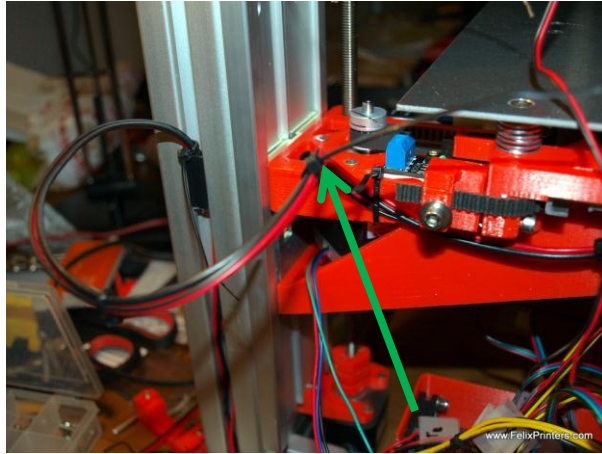

Make sure the loop is intermitted at the top part of the z-axis carrier. Mount it there with a cable tie. Then make the second loop from the z-axis carrier to the vertical beam. The second loop should go into the vertical beam at approx. the middle.

## 11.6 Connect the rest of the wires

After connecting the motor wires the only wires left are the following:

- Wires for the hot-end
- The 3 fans
- Power supply wire, power ON/OFF wire

### 11.6.1 Wires for the hot-end.

The supplied hot-end contains all the wiring, only connect the two thermistor wires with a 2-lead precrimped wire. The heater cartridge wires are long enough to directly connect to the ramps electronics. Please check the schematics

### 11.6.2 The 3 fans

1. The fan which is connected to the air duct underneath the extruder motor needs to be connected to the ramps board. It is a switchable fan and should be connected next to the heated bed power resistor connection. Make sure the polarity is the same as in the schematics, because otherwise the fan will be damaged/unusable.
2. The fan which blows cool air to the top part of the hot-end is a non-switchable fan and needs to be connected to a +5 Volt (dark red) cable and a black cable directly from the power supply. Again watch the polarity, when wrongly connected the fan will be damaged beyond repair.

Note: The fans are rated for 12V, but when connected to 12V it makes a significant amount of noise. Since the cooling capacity at 5V is more than enough. Another benefit is that the fans make virtually no sound at 5V

3. The fan in the ramps electronics case, this is the same as the 2<sup>nd</sup> fan. It constantly blows cool air and therefore must be connected to a 5V and a 0V cable of the power supply

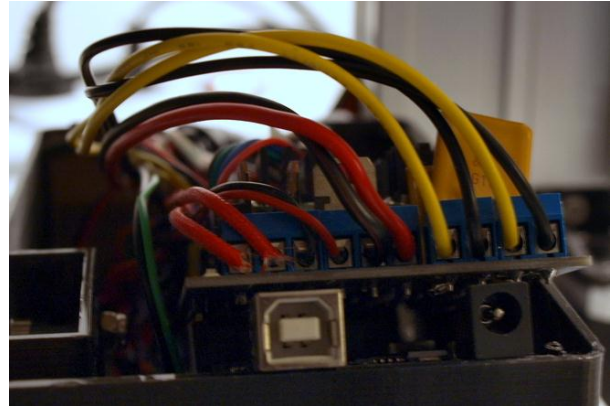

The order of the cables for the screw terminal in more detail.

From left to right.

2x Hot-end powerresistor cables, airduct fan black, airduct fan red, 2x heated bed powerresistor cables, 12V yellow, COM black, 12V yellow, COM black.

The wire colors of the hot-end and heated bed can be different from the wires in the picture.

Make sure the polarity of the fan cables are according to the schematics!!! Otherwise the fan will be damaged.

## 11.7 Clean it up.

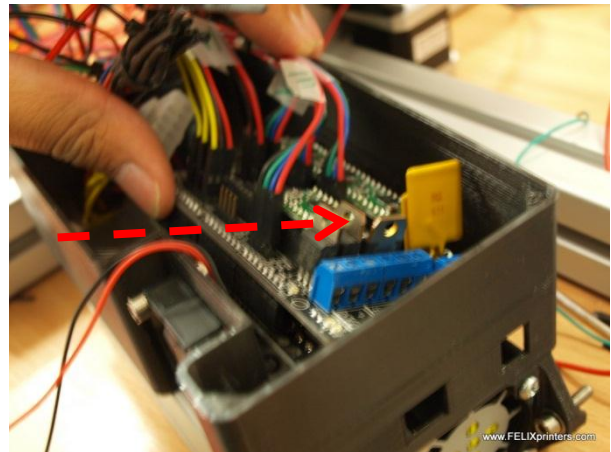



# FELIXPrinters

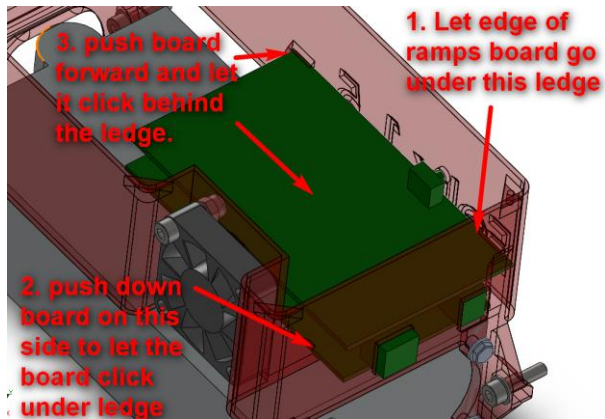

Move the board in, see picture above to see how to properly do it.

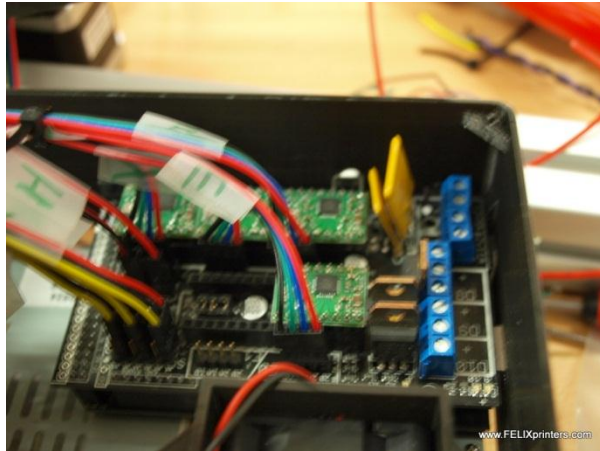

It should look like this when properly positioned.

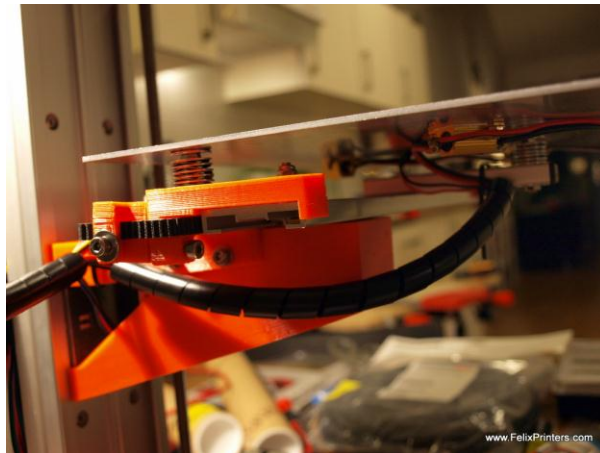

Try to make the loops look nice by putting it in the cable spiral. Remove the cable-ties from the loops.

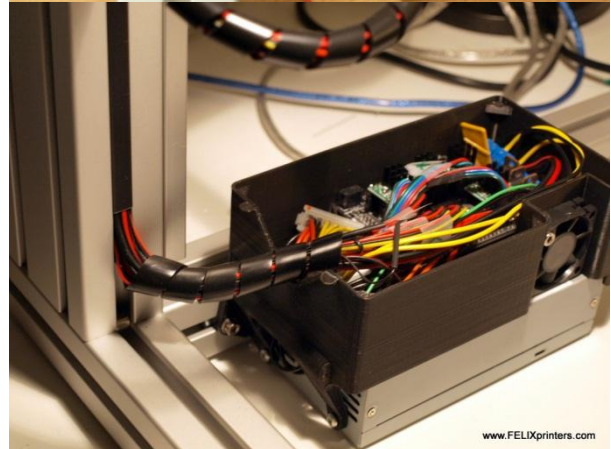
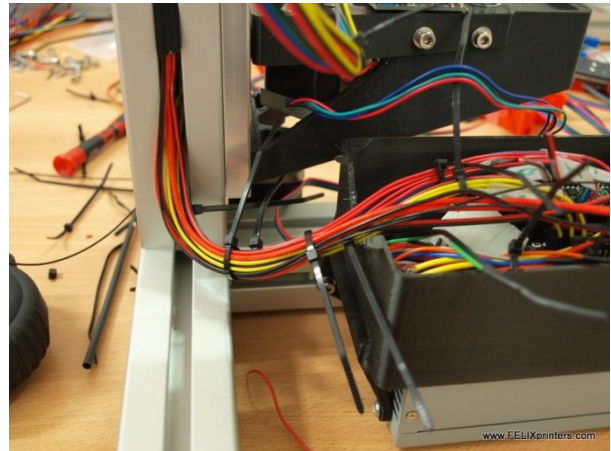

Finally manipulate the bundled cable to let it through the opening. The cables must be pushed flat because the lid of the box must be placed on there. If there are too many cables you can try to slide the whole powersupply slightly to the right to make the cables more flat in the box.

# FELIXPrinters

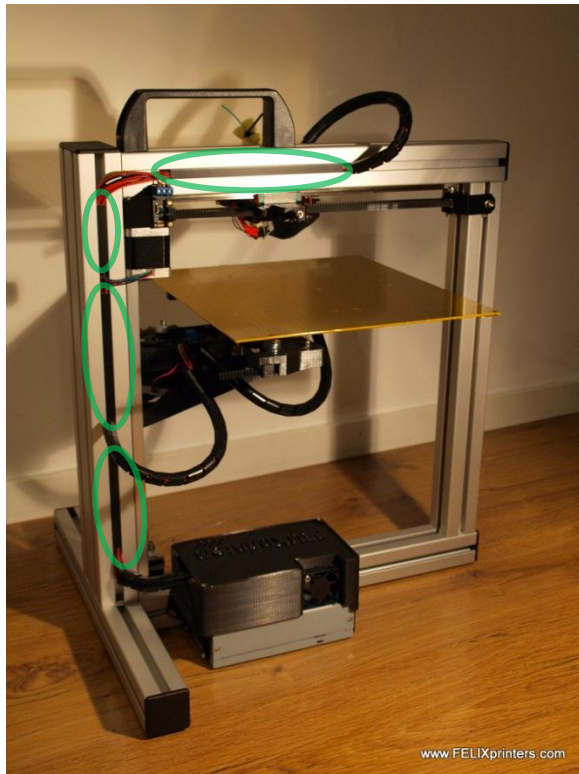

Cut a piece of frame-strip to hide the cables that run through the frame. As indicated in green above.



Depending on your shipment, you can have either the thermal pads or you have to put the supplied thermal paste on the heat sinks.



Heatsink

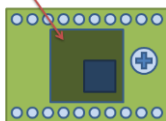

Place the heat sinks on the square chip on the stepper drivers like the picture above. Try to place the heat sink between the pins without touching them, the heat sink must make full contact with the chip in order to have good thermal conduction. The thermal paste will dry over time.

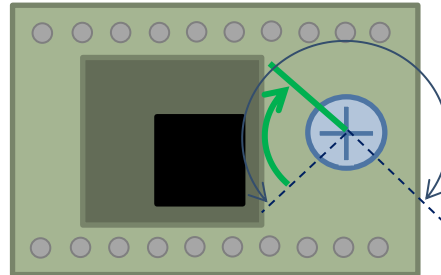

**Important note:** The potmeter (little screw) on the stepper drivers are mostly set incorrect out of the box. The pot meters have a turning range. Fully counter clockwise is no power to the stepper drivers. Fully clockwise is full power to the stepper drivers. The stepper drivers cannot handle fully clockwise because that demands too much power for the stepper driver and it will overheat. There is a self protection mechanism in the chip which will temporarily turn the chip off to cool itself down. It will protect itself, but this is of course unwanted behavior as it will give intermittent movement during printing. Do the following as a starting point.

1. Turn the screw fully counter-clockwise.
2. Turn it clockwise a quarter turn.

This will give a good starting point for finetuning later.



Finally the front view of the printer should look like this.

Congratulations you are done with the electronics part and it is time for some finishing touches.



## 12 Finishing touches (time: 30-45 min.)

1. Check all the bolts if they are tightened correctly.
2. Check if all the axes can move freely, without cables being jammed.
3. Put a little bit of oil or grease on the z-spindle, to make it run smoothly. Preferably a thicker kind of grease or oil, we use motor-oil.
4. When you have a printer with a shining through color, the opto-sensors of the axes might not work. To make them work you can put one of the following things on the switching vanes:
  - a. Non-shining through tape on the flange
  - b. Tippex
  - c. Piece of aluminum foil



5. Mount the z-axis limit switch. Preferably put it 5 cm below the top edge of the z-axis rail. This way you prevent the hot-end from hitting the table before the switching vane triggers the opto sensor.

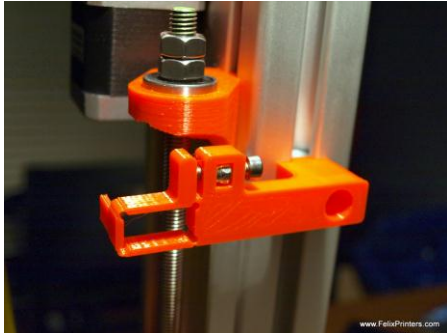

6. Mount the frame handle. Use the supplied M8 frame nuts and bolts to mount it. Place the frame holder as close to the vertical frame beam as possible.



Prepare the heated bed.



# FELIXPrinters

In this step the goal is to put a layer of tape on the surface of the heated bed. This layer makes sure the extruded plastic will correctly stick on the bed.



Degrease/clean the bed with some detergent. We use spirit, but alcohol, thinner, nail polish remover will work also.

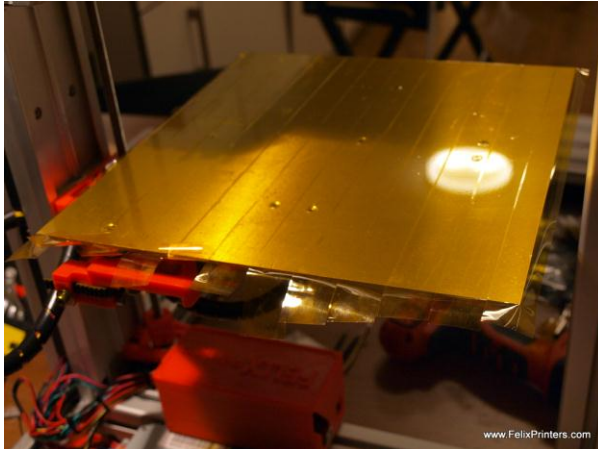

Put strokes of the supplied tape on the heated bed. Try to do this with as little bubbles and overlap of the strokes as possible. The better you do this the nicer the bottom surface of the printed parts will be.

Fold the overhanging strokes of plastic around the edges. Then afterwards clean the surface with detergent.

Supplied with the kit is kapton tape. After several tests with different kinds of tape we at FelixPrinters recommend the following:

- Kapton tape. Very good for printing, but costly
- PVC tape, has the same sticking quality as kapton tape, but significantly lower costs. Downside is the durability of the tape. Needs to be replaced more often.
- Painterstape. This is only recommended for very small parts, with small contact surface to the bed. With PLA filament this tapes sticks so well that the printed parts are extremely hard to remove from the bed. To not damage the build platform for certain parts we had to remove the parts including tape. This tape is also a suitable tape for printing with ABS.

## 13 Calibration of table (5-15 mins)

For a successful print it is important that the table is properly calibrated, which means it should be level. The table can be leveled by turning the 3 M4 nuts underneath the heated bed. **!!The calibration is done by moving the axes by hand!!**

Steps:

Calibrate the table in y-direction.

1. Move the X-axis carriage(extruder) to the homing sensor
2. Move the Y-axis (heated bed) to the homing sensor
3. Move the table up until approximately 1mm from the hot-end.
4. Goal is to move the y-axis and to get the distance between the tip of hot-end and the heated bed the same over the whole movement.
5. Move the bed over the hole movement range and while moving adjust the adjustment screws underneath the table to level out the table in y-direction.
6. Move the table a little closer to the hot-end and repeat the previous step.

Calibration in x-direction

7. Move the table to the middle of its movement range
8. Move the X-axis carriage over it's movement range. While moving check the distance between the hot-end and bed. If the distance is not even, adjust it with the nut which supports the middle of the table.

You are done-calibrating the table.

Calibration in Z-direction.

9. After leveling the heated bed, the homing z-position should be correct. This can be adjusted by tweaking the z-axis switching vane. This will be done after installing the software. See further ahead in the manual
10. Press the homeZ button
11. After the home movement is finished, check the distance between the hot-end and the table. This should be approximately the layer height of a printed layer. In our case that is 0.32mm. Use a sheet of paper as distance measurement.
12. If it seems ok than you are finished otherwise adjust the z-axis switching vane.

## 14 Making printer ready for operation. (30 – 60 mins)

The software used to control the printer is open source. It is available for different platforms. This manual currently only covers the WINDOWS version of the print software. For other platforms, guides should be available on the internet.

The software installation is split up in two steps.

Step 1: Firmware installation

Step 2: Printer software

Step 3:

### 14.1 Firmware installation

Go to the FelixPrinters <http://www.felixprinters.com/support.html> and follow the download links to get all the required software.

This step requires the following software:

- Arduino, platform to upload firmware to the printer.
- FELIX firmware for RAMPS 1.4,(check the revision of the printer). Contains printer settings for correct operation of your Felix printer.

Steps to upload new firmware to the FelixPrinter

1. **Make sure the power cable of the power supply is disconnected!!!**
2. Plug in the USB cable into the RAMPS electronics and do the following:
  - a. Check switching vane operation: Make sure the black slots of the opto sensors are free. Move the switching fans over them by moving all the axes by hand. If the lights go out, the opto's are installed correctly.
3. When the USB cable was plugged in Windows will normally automatically install the correct drivers. If this is not the case then download drivers from here: <http://www.ftdichip.com/Drivers/VCP.htm>.
  - a. Go to start->right-click on "Computer"-> click properties -> in left pane click "Device Manager"

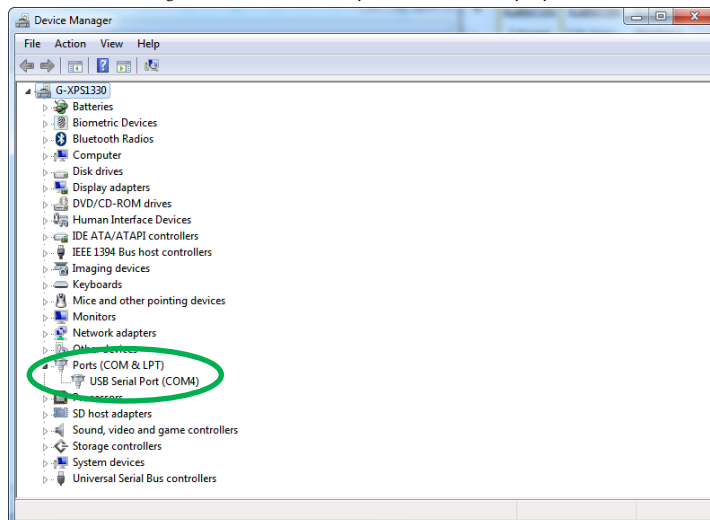

- b. Note what COM-port is present. If there are more than one COM ports available unplug the RAMPS USB cable, and re-plug it again. Check what port number is appearing and disappearing. This port number will be used for the next step.
4. Start Arduino software  
It should look like this:



# FELIXPrinters

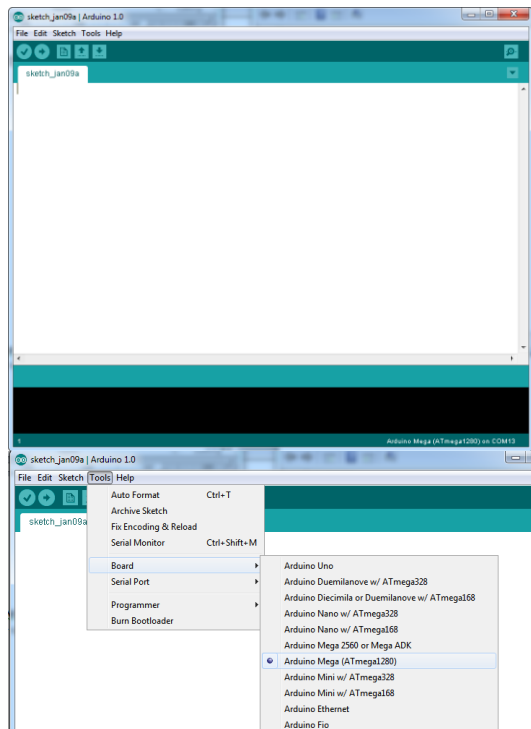

Select the correct platform:

Tools -> Board-> Arduino Mega(ATmega1280)

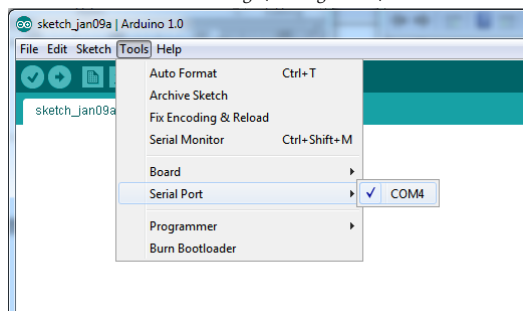

Select the correct Serial Port which you've noted earlier

Tools -> Serial Port -> COM...

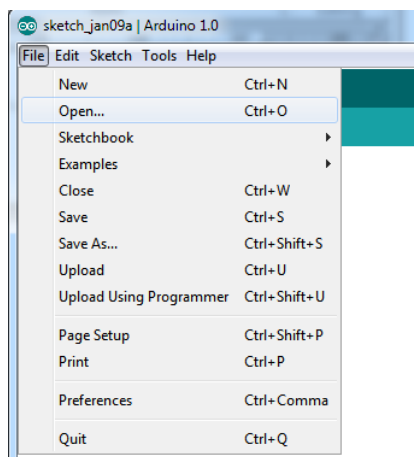

Extract the downloaded FelixPrinter firmware to some folder.

Open this folder through the Arduino interface and click on the *Marlin.INO* file.

# FELIXPrinters

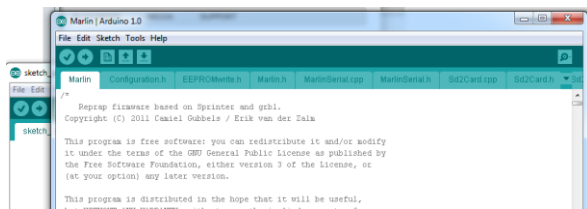

A new window will pop-up, with all the source firmware files. All the settings for the FelixPrinter to work correctly are configured. Feel free to browse around the files to get a better understanding of how it all works.

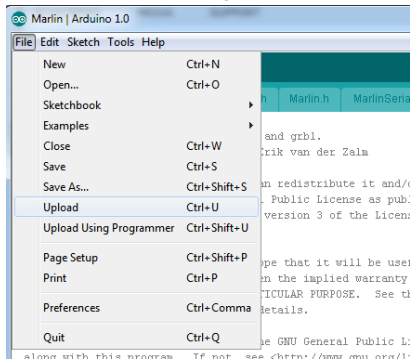

It is time to upload.

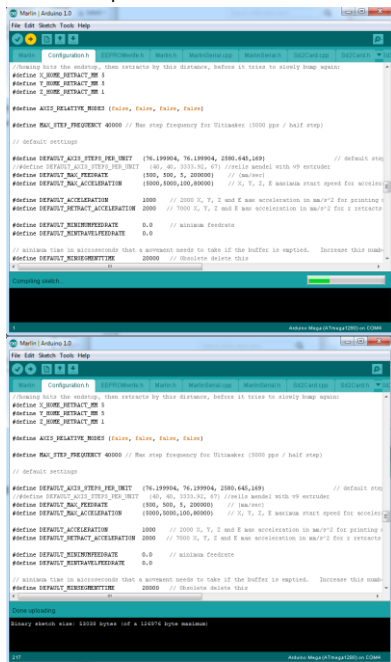

You are done with the firmware upload.

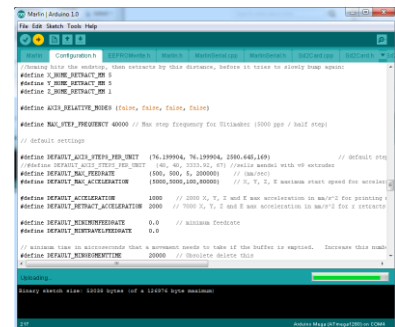

## 14.2 Printer software – Repetier-Host

This software controls the printer. Also your CAD design files can be calculated and printed out by this program.

1. Download latest version of Repetier-Host from [www.felixprinters.com/downloads](http://www.felixprinters.com/downloads)
2. Extract the zip file. The following files/directories should appear. Choose the setup....exe file to install Repetier-host.

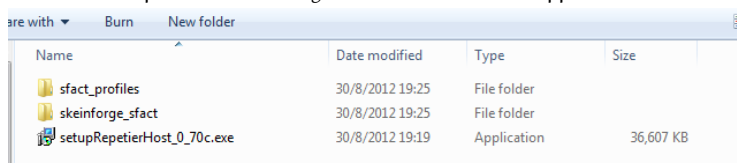

# FELIXPrinters

Select the two directories and copy them into the installation directory of repetier-host

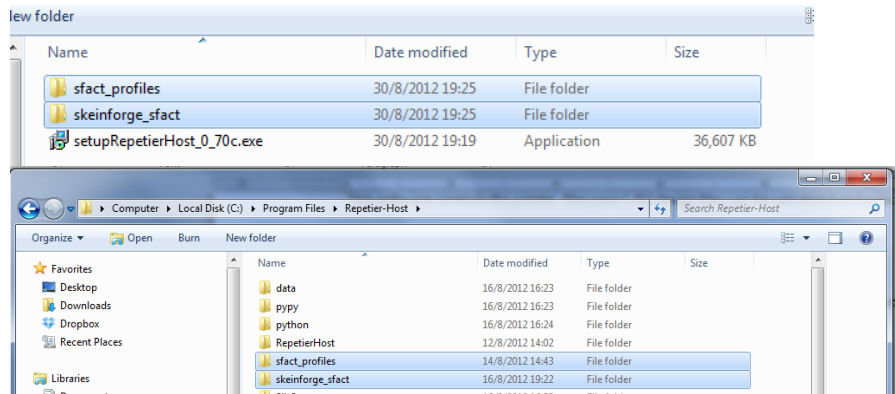

### 3. Start Repetier-host.

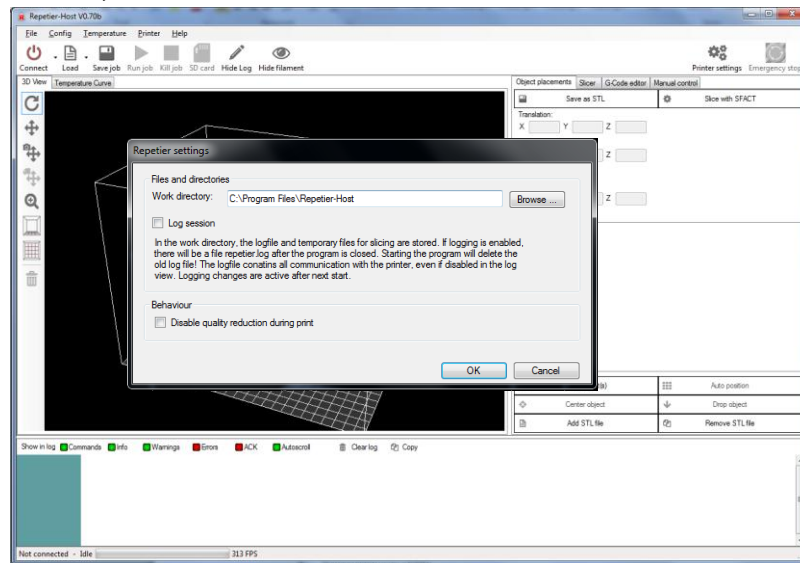

The program will ask for a working directory. Recommended is to use the installation directory. In our case that is: *C:\Program Files\Repetier-Host*

### 4. Go to Config -> Printer settings.

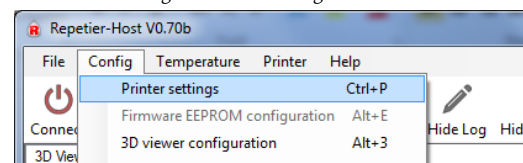

Match all the settings from the tabs. The com13 in the pictures is probably different for your situation. The com port is obtained in previous steps of the manual.

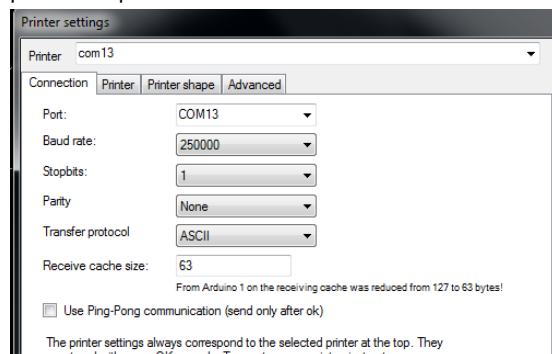



# FELIXPrinters

Printer settings

Printer: com13

Connection | Printer | Printer shape | Advanced

Travel feed rate: 4800 [mm/min]

Z-axis feed rate: 600 [mm/min]

Default extruder temperature: 210 °C

Default heated bed Temperature: 65 °C

Check extruder and bed temperature

Remove M105 requests from log

Check every 3 seconds.

Park position: X: 100 Y: 0 Z-Min: 0 [mm]

Go to park position after job/job kill

Disable extruder after job/job kill

Disable heated bed after job/job kill

Disable motors after job/job kill

Add to comp. printing time: 8 [%]

Printer settings

Printer: com13

Connection | Printer | Printer shape | Advanced

Print area width: 260 mm  Home is at x max

Print area depth: 200 mm  Home is at y max

Print area height: 200 mm

Printer has dump area

Dump area left: 125 mm

Dump area front: 0 mm

Dump area width: 22 mm

Dump area depth: 40 mm

Printer settings

Printer: com13

Connection | Printer | Printer shape | Advanced

Post Slice Filter

Filter path and parameter:

yourFilter #in #out

Run filter after every slice

You can run a filter program after each slicing action. The filter will be run on the G-Code produced by the slicer. Use #in and #out to insert the input and output filenames as parameter.

- The software is now configured for printing. Now it is time to configure the slicer. This is the part which slices a CAD file and prepares it for printing. Go to Slicer and press setup.

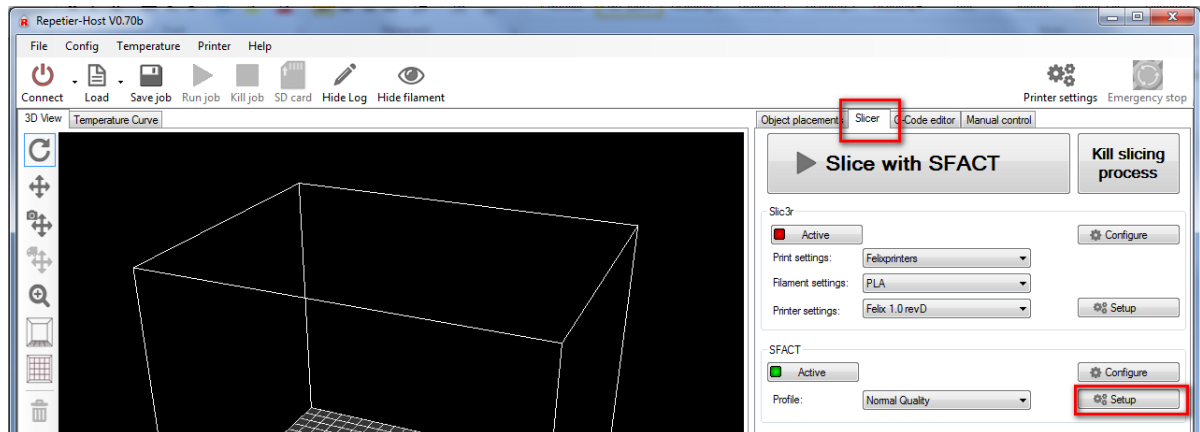

Match all the fields in the picture below and afterwards press OK.

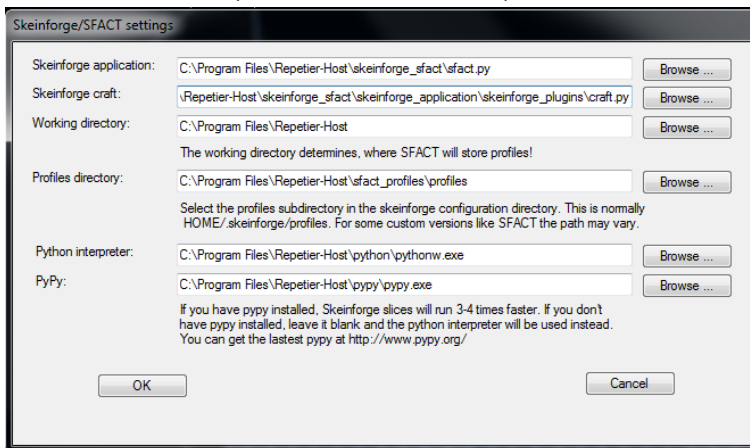

- Press the Configure button

The slicing settings must come up. Check under profile selection if there are several profiles present. If this is the case then the configurations are set correctly. Close this window.

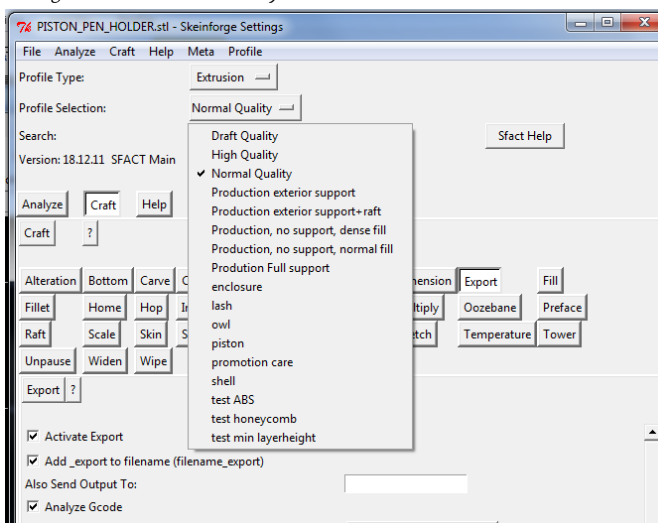

- Now back in the repetier main interface Activate the SFACt slicer. Now check if all the profiles are present.

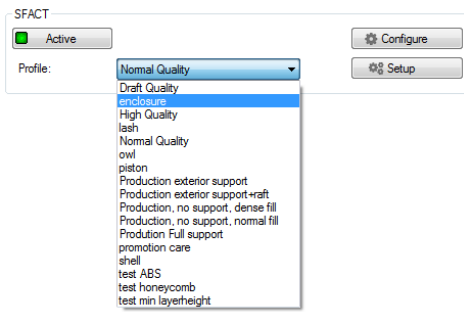

- Now it is time to slice our first object. Press the Add STL file. Then navigate to the installation folder of repeterhost and choose the `_40x10.STL` file from the subfolder displayed in the picture below.

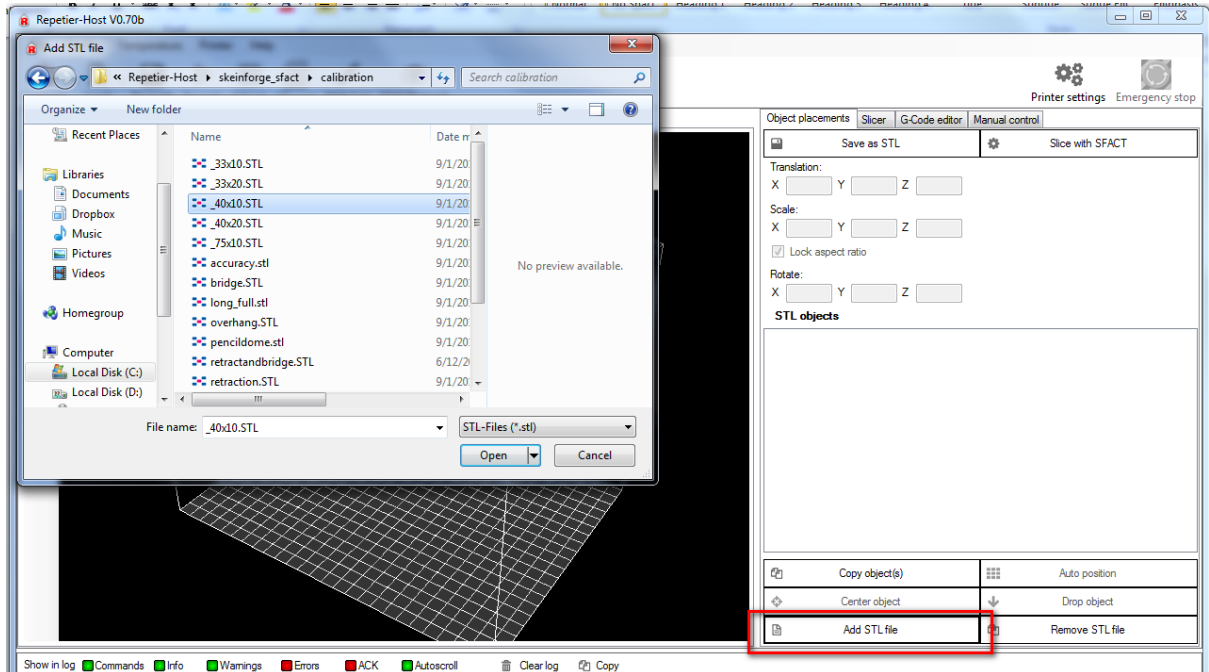

- Slice this file and prepare it to print. Press the *Slice with SFACT* button

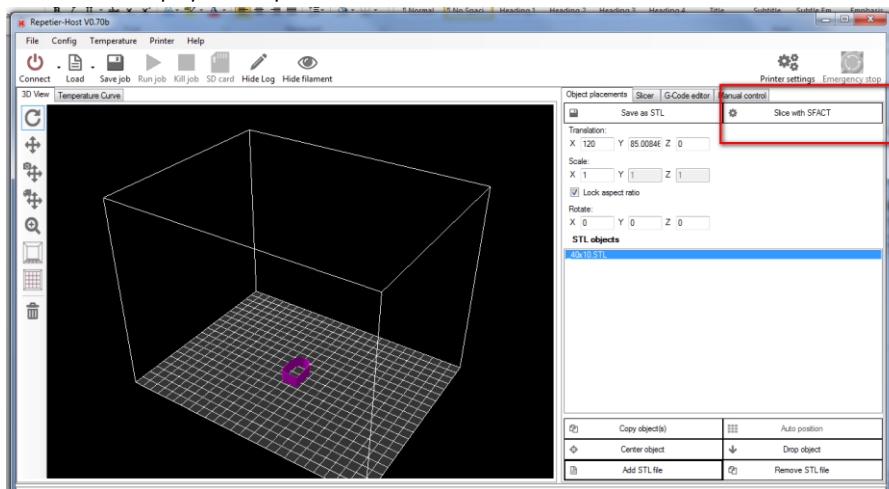

When the program is done after slicing the interface should look like this:



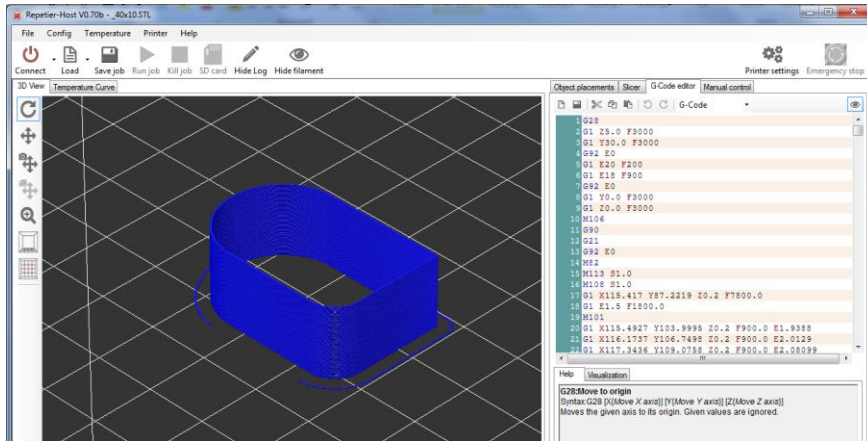

10. After slicing

### 14.3 Calibrate the Z-direction/ Connect to printer

To obtain good quality prints it is essential that the heated bed is level and that the distance between the hot-end and the bed is close enough. The leveling is done prior to the software installation. So now it is time to calibrate the z-axis height with the z-axis limit switch vane.

1. Make sure if you have a shining through color printed parts for the printer to apply the tape, tipexx to the limit switch vanes.
2. Connect to the printer. (The connect button should turn green)

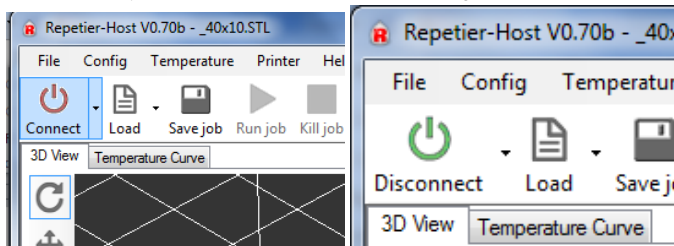

Other checks to see if the printer is connected properly:

On the bottom of the repetier host program the following should be displayed

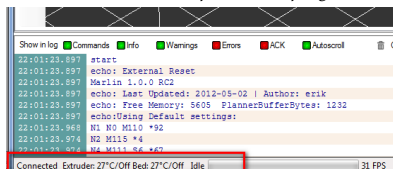

If you see ... commands waiting, press the reset button on the electronics at the front of the electronics case.

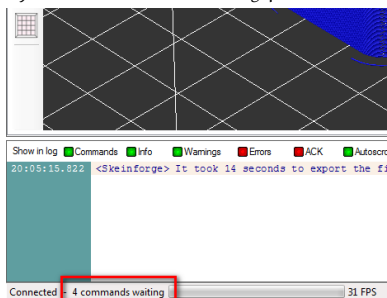

3. Go to the *manual control* tab

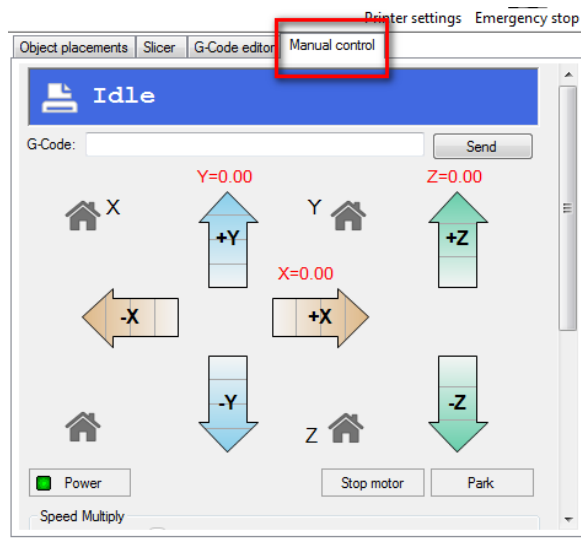

Now it is time to calibrate the z-height.:

- Plug in the power cable. When doing the following steps, hold your hands on the usb connector. Plug it out if something goes wrong.
- Make sure the fan in front of the hot-end and the fan in the electronics case is turning.
- Make sure the bed is 1 cm from the hot-end.
- Press Home X, then move the x axis back and forth. The axis will only move in positive direction if the Home X button is not pressed.
- Press Home Y, move the y axis back and forth.
- Press Home Z
- The distance between the table and hot-end is probably too large.
- Adjust the limit-switch vane and press Home Z again.
- Do this a couple of times until the distance is less than the thickness of a piece of normal paper.

Scroll down the manual control window.

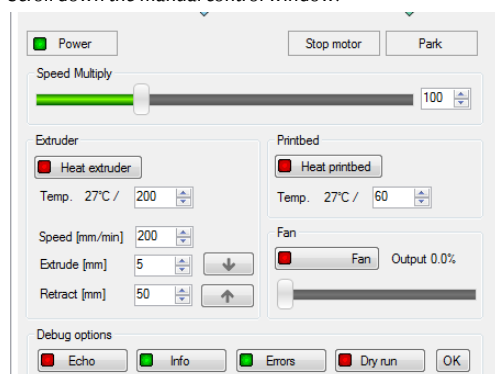

- Check if the switchable fan mounted to the airduct is working.  
Move the slider to 100%, (other values don't work) and press the fan button

You are almost ready to do your first print, please proceed to the next section.

## 15 It's time for printing! (15- 30mins)

After all the hard work of the assembly and setting up the machine it is time to get some reward by means of your first successful print. Before pressing the "Print" button make sure of the following

In the manual control window do the following.

- Heat up the extruder to 200 degC
- Heat up the heated bed to 60 degC
- Move the table down 10mm

If the extruder is heated up, check or make sure that the following is true

- Printer axes can move without obstructions
- Remove all plastic residues on the heated bed.
- Degreased heated bed surface
- When all axes are homed the hot-end is not touching the table.
- The supplied filament with the kit is PLA. The optimal temperature depends on the type of filament used. When using PLA check if the temperatures of the hot-end and the heater are between 180-210 and 30-60 degrees C respectively. When using ABS these temperatures should be somewhere around 210-250 and 70 – 100 degrees respectively. The heated bed temperatures can be much lower with painters tape.
- To find the correct temperature for optimal extrusion, start with a low temperature. Then go up slightly. When the temperature is too high, you might hear some pops and sisses coming from the hot-end. When the temperature is too low the extruder motor will have a hard time extruding. When printing at high speed, the temperature of the filament should be a little higher.
- Move down the table 10mm and insert the filament in the extruder. Run the extruder until a steady flow of plastic comes out. Remove this with tweezers.
- When there is not a continuous flow coming out of the nozzle, make sure the extruder arm is properly tensioned. Turn the m4 nut counterclockwise to put more tension on the filament, so it will be pulled into the hot-end better. But watch out, too tight and the motor will have a hard time to turn.
- 

When these steps are OK, you are ready to press that print button.

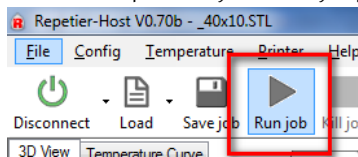

If the calibration was done ok the print should finish without any problem.

The most probable cause of failure could be the wrongly adjusted z-height of the first layer.

Two things can happen:

- The plastic won't stick to the heated bed. This means the distance between the table and the hot-end is too large
- The first layer sticks but seems squashed, compared to the other layers. This means the hot-end is too close to the table.

If one of the above failures happens, adjust the z-axis switch vane accordingly.

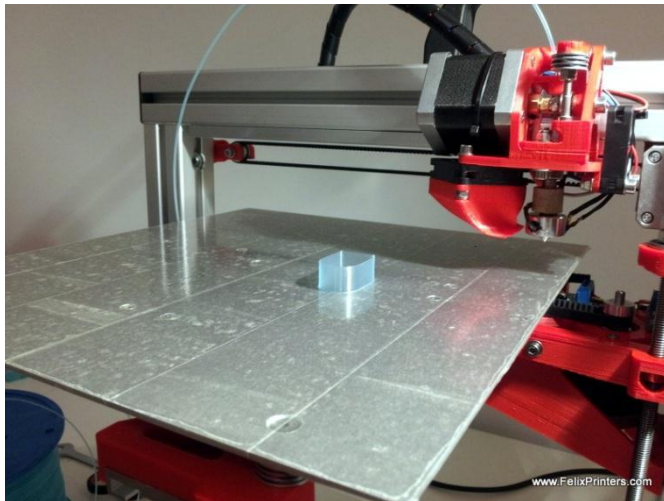

If the print looks like the picture above than congratulations your printer is completed!!

**IMPORTANT info:**

To keep the hot-end running as long as possible, let the filament run through a dust collector like a small piece of sponge. The filament picks quite a lot of dust due to static charge or dirt from the factory. This will all enter the hot-end and partially stick in there and finally clog the nozzle. When this happens the hot-end needs to be drilled out when hot from both sides. A tutorial for this is available on the forum on the website.

When changing different kind of filament it can be done in 2 ways:

- 1 Just cut the old part just above the extruder and keep running the extruder until you can feed the new filament.
- 2 Retract the current filament out of the extruder and then insert the new one.
  - To get the old filament out, retract 50 mm with a high velocity (1000mm/min). This is advised because fast retraction reduces stringing to a minimum. The little strings of molten plastic are able to jam the inlet of the hot-end. When this happens, you need to take out the hot-end and remove the plastic.
  - Then feed it again with a low velocity of 200mm/min.



## 16 Quest to high quality printing

After experimenting a little with the printer, you probably want to get the most out of your printer. This chapter addresses some categories to increase print quality.

### 16.1 Thermodynamics

Filament printing temperature is an important parameter. There is usually one optimal temperature to print at, this is different for each material type and even for different colors of the same material.

PLA prints somewhere between 180 to 210 degrees C.

ABS from 220 to 250 degrees.

This will happen when printing at too low temperature:

- The printed parts will become brittle, because the printed layers do not stick very well.
- Extruder needs a lot of force to push the filament through the nozzle. It can happen that at high print speeds, the force demand could not be fulfilled, which result in skipped steps of the extruder motor.

When printing at too high temperatures:

- You will experience ooze(little strings) of the filament.
- You could hear bubbles pop, this can be evaporated water inside the filament.
- Printing small prints will be difficult because when printing the next layer, the previous layer could still be soft.

**TIP:** when printing very small objects try to print at low speed or try to print more at once, this gives to previous printed layers time to cool down a bit.

#### Heated bed

The first layer which is in contact with the heated bed is the foundation of the printed part. You want to make sure that this first layer is near perfection. Sometimes it can be troubling to get parts to stick to the bed, or parts can come loose at the edges after a while. This can be because of the following:

- Bed surface is not degreased enough.
- Temperature of the heated bed is too low, try increasing it with 5 degrees
- Bed is not level. Make sure the bed is perfectly level, especially for large prints it can be that the distance of the hot-end to the bed is too much at one side of the print, when the bed is not level.
- Print speed of first layer is too fast.
- Hot-end temperature is too low. Try increasing it 5 degrees.

### 16.2 Mechanics

#### Belts/Pulley's

Usually when perimeters of experiencing bad print quality, this can mean the following. Make sure the pulley's are tightened.

1: Pulley's are not tightened enough

2: Belt tension is not high enough.

#### Hot-end

Check that the hot-end is fixed in the extruder carriage. If not, the prints will come out ugly.

## 16.3 Software.

High print speeds is nice, but you will suffer print quality. To have a good compromise between speed and quality, an infill speed of 80mm/s is a good start, then take the perimeter speed at 30 or 40mm/s.

## 17 FAQ

**Q: Sometimes the extruded filament looks ugly or has a varying diameter:**

A: Not homogenous extruded filament can be caused by the following:

- Check the filament quality. Bad quality filament can have a varying diameter from 1.95 to 1.4mm instead of a continuous 1.75mm.
- There is not enough tension on the extruder arm. Increase the tension on the extruder arm a little. Be careful by not to put too much tension, because the extruder motor can have a hard time turning
- Filament gets stuck somewhere. Check if the feed of filament to the extruder is going without any obstructions.

**Q: There is a lot of backlash in the axis-movement:**

A: Check the following:



















- The belt is tensioned properly
- The set-screw on the motor-pulley is tightened enough

**Q: When looking at walls of the printed parts, there are waves noticeable.**











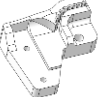
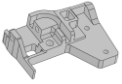

A: The reason for this is that the shaft of the motor, z-axis coupling and z-axis rod are not aligned properly. When the z-axis is rotating there should not be a wobble noticeable. Try to do the following:

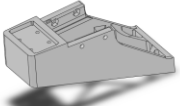
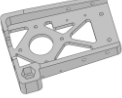
- Remount the z-axis coupling in the following way.
  - Try to turn the screws at the motor side of the coupling one by one and bit by bit. Each turn should be by ¼ turn. Try to fix it loosely and try to keep the bottom of the coupling parallel to the motor face as good as possible
  - Do the same for the top 2 screws of the coupling.
  - Turn the coupling by hand and see what side the wobble goes when turning. Then try to turn the screws in such a way that the spindle is moved in the opposite direction of the wobble.
  - When this seems ok, try to move the axis 10 mm up with pronterface. And see if there is still a noticeable wobble.
- The large M8 nut situated in the z-axis carrier part could be too tight in the slot. Try to file the hole out some more so it can move more freely.

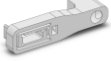
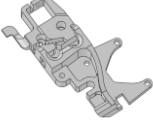
## 18 BOM Felix 1.5

Bolts and screws	Amount	
ISO 4029 - M3 x 6-N - Set screw	6	
ISO 10642 - M3 x 8 --- 8N - Countersunk	28	
ISO 4762 M4 x 12 --- 12N	8	
ISO 7380 - M4 x 12 --- 12N button head	6	
ISO 4762 M4 x 16 --- 16N	16	
ISO 4762 M4 x 20 --- 20N	10	
ISO 4762 M4 x 25 --- 25N	6	
ISO 10642 - M4 x 30 --- 30N - Countersunk	4	
ISO 4762 M4 x 40 --- 20N	4	
Washer ISO 7089 - 4 - (small washer)	35	
Corrosserie ring - M4 - (large washer)	25	
crinkeled washer	25	
Powersupply screw	7	
bronze small screw	8	
Hexagon Thin Nut ISO - 4035 - M3 - N	10	
Hexagon Thin Nut ISO - 4035 - M4 - N	12	
Hexagon Nut ISO - 4034 - M8 - N	6	
ISO 7040-M4-N - self prevailing nut	16	

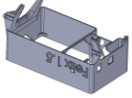









# FELIXPrinters

Printed Parts		
x-stage-motor-bracket_v6_F1_5	1	
x-axis belt mount_v5	2	
y-stage bracket pt1_v6_F1_5	1	
y-stage bracket pt2_v5_F1_5	1	
y-stage bracket pt4_v4	2	
z-spindelmount bottom - v2	1	
z_axis_carrier_pt1_v9	1	
z_axis_carrier_pt2_v5	1	
z-axis-motor-bracket_v8	1	
z-axis-limitswitch_vane_v4	1	
Extru_base_v9_F1_5	1	
Extru_base_pt2_v5_F1_5	1	
Extru_arm_v4_F1_5	1	
Extru_airduct_v2	1	
Extru_base_pt4_F1_5	1	
electronics_case_v2_ramps	1	
electronics case capv1_F1_5	1	

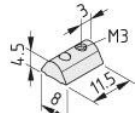
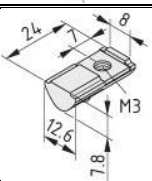





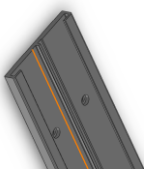
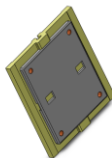

# FELIXPrinters









Electronics		
Heater Cartridge incl 2m wires (pre-assembled in hot-end)	1	
Thermistor incl 2m wires (1 is pre-assembled in hot-end)	3	
RAMPS + arduino + steppers fully assembled	1	
Fan 40x40x10mm	3	
mini-ATX-seasonic, powersupply	1	
Power Cable EU(optional)	1	
Power Cable USA(optional)	1	
Power Cable Australian(optional)	1	
Power Cable British(optional)	1	
optosensor	3	
motor nema 17	4	
Resistor 4.7 Ohm - heated bed	4	
heatsinks 10*8	4	
precrimped cables 4 threads	4	
precrimped cables 3 threads	3	

precrimped cables 2 threads	2	
Shielded USB cable 1.8m	1	
heatshrinks large 50 cm	1	
Heatshrinks small 15 cm	4	
Piece of 2 thread wire 2m, for heatbed	2	
<b>Mechanics</b>		
Hiwin linear ball bearing set	2	
t_slot_nut_5_M3	2	
t_slot_nut_8_M3	3	
ISO 10642 - M3 x 6 --- 6N - CSK	5	
Hexagon socket head cap screw DIN 912 - M3 x 8	2	
Hexagon socket head cap screw DIN 912 - M3 x 12	4	
Hexagon socket head cap screw DIN 912 - M3 x 16	10	
Prevailing torque type hexagon nut ISO 7040 - M3	6	
Washer ISO 7089 - M3	10	
Igus GmbH_NS-01-80 - rail	1	
Igus GmbH_NW-02-80 - cart	1	

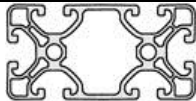
# FELIXPrinters

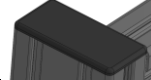
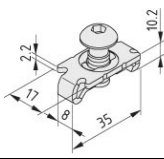

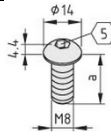
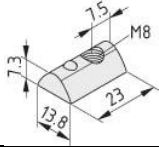
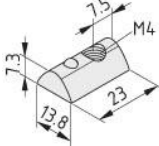



pulley_motor_HTD	2	
Toothbelt 1.5m	1	
z-spindle (M8 rod, 330mm)	1	
bearing-8x22x7	1	
bearing 5x12x6	4	
extruder_insert_piece	1	
y-axis mid-table support 20x10_profile + protective cap	1	

# FELIXPrinters

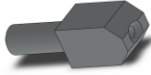
<b>Frame</b>		
40x40x400 profile, incl 2xM8	1	
40x40x400 profile, incl 1xM8, 1xD7	2	
40x40x400 profile, incl 3xD7	1	
80x40x440 incl work	1	
40x40 protective caps	4	
80x40 protective caps	1	
frame connector set	6	
handle incl protective cap	1	
hex sockethead bolt M8x16 buttonhead	2	
t-slot nut - 8 ST M8	2	
t-slot nut - 8 ST M4	22	
dampning feet	6	
strip for putting away cable pieces of 40 cm	2	

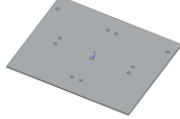

# FELIXPrinters

<b>Fabricated parts</b>		
Hot_End_base_3mm	1	
Hot_End_peek_isolation_3_v2	1	
hot_end_heated_nozzle_3	1	
table_2mm	1	
Z-axis coupling_v11		
<b>Others</b>		
tweezers	1	
tape for heated bed	1	
cable ties, set of 100	1	
cable spiral 1.25m	1	
piece of selfadhesive tape 10cm	1	
Piece of filament to start 5m	1	
Silcone kit	1	
Cooling paste	1	